

# K-940

## Temperature-Compensated Pet-Immune PIR Detector



# Visonic

## Installation Instructions

### 1. INTRODUCTION

The **K-940** is an advanced pet immune PIR detector, that utilizes TSI™ (Target Specific Imaging) technology, ensuring immunity to pets weighing up to 18 kg (40 lb).

The detector is also notable for its high stability, enhanced RFI protection (greater than 30 V/m), high-temperature compensation for maximum "catch" performance and unique low-temperature compensation for optimum false-alarm rejection. The pyroelectric sensor of the **K-940** is enclosed in a sealed chamber, protected

from insects and air drafts. The pulse counter may be switched between 1 and 3 pulses, as desired.

Besides regular wall and corner mounting, three optional swivel brackets are available to increase the versatility of installation.

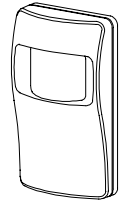

Figure 1.  
General View

### 2. SPECIFICATIONS

#### OPTICAL

**Max. Coverage Range:** 9 x 9 m (30 x 30 ft) / 90°.

**Pet Immunity:** Immune to animals weighing up to 18 kg (40 lb).

**Vertical Adjustment:** 3-position adjustment scale: 1.8 m (6 ft), 2.1 m (7 ft) and 2.4 m (8 ft).

**Note:** *Pet immunity specifications have not been verified by UL.*

#### ELECTRICAL

**Voltage:** 9 to 16 VDC.

**Current:** 17 mA at 12 VDC, 21 mA at 16 VDC

**Alarm Output:** Normally closed (fail-safe) contacts. 18 ohm resistor in series with contacts. Rating - 0.1 A resistive / 30 VDC.

**Tamper Output:** Normally closed, rated 0.5 A resistive / 30 VDC.

**Alarm Period:** 2-3 seconds.

**Pulse Counter:** 2 position selector, 1 or 3 pulse operation.

**LED:** Walk test enabled or disabled with internal link.

**Detector:** Dual-element low noise pyroelectric sensor.

**MOUNTING:** Surface or corner (without brackets).

**Mounting Height:** 1.8 m (6 ft) to 2.4 m (8 ft)

**Optional Mounting Brackets** (See Figure 3)

**BR-1:** Swivel Bracket, adjustable 30° down and 45° left, 45° right.

**BR-2:** BR-1 with corner adapter; **BR-3:** BR-1 with ceiling adapter.

#### ENVIRONMENTAL

**Operating Temperature:** -10°C to 50°C (14°F to 122°F).

**Storage Temperature:** -20°C to 60°C (-4°F to 140°F).

**RFI Protection:** >30 V/m to 1000 MHz.

#### PHYSICAL

**Size (H X W X D):** 104 x 60 x 32 mm (4.1 x 2.4 x 1.3 in.).

**Weight:** 77 g (2-3/4 oz).

**Color:** White.

**PATENTS:** U.S. Patent No. Des. 346,567

### 3. INSTALLATION

#### 3.1 Mounting

The **K-940** can be surface mounted on a wall or in a corner. For optional swivel brackets, see Para. 3.2 and Figure 3.

**A.** Select the mounting location so that the expected motion of an intruder would cross the detector's coverage pattern.

**B.** Mount the unit at the height of 1.8 m (6 ft) to 2.4 m (8 ft).



**Important!** The detector is immune to 18 kg (40 lb) animals moving on the floor or climbing on furniture as long as the activity takes place below 1 m (3 ft). Above the 1 m (3 ft) height limit, the detector is immune to 9 kg (20 lb) pets, but the pet immunity will decrease as the pet gets closer to the detector. It is therefore recommended to select a mounting location that minimizes potential close proximity of animals.

**C.** It is advisable to avoid aiming the detector at heaters, sources of light or windows subjected to direct sunlight. Also avoid running wiring close to high power electrical cables.

**D.** To remove the front cover, open the screw at the bottom of the unit. A keyhole shaped slot permits easy removal of the PCB by just loosening the adjustment locking screw.

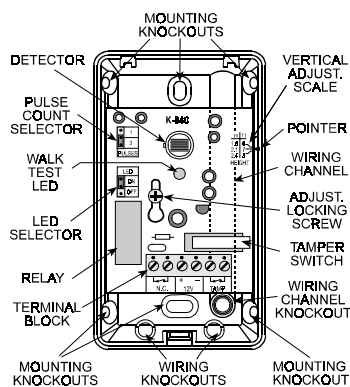

Figure 2. Components Layout

**E.** For surface mounting use the two knockouts at the back of the base; for corner mounting use the knockouts on the angled sides. The unit must be fastened firmly to the mounting surface, to avoid possible vibrations.

#### 3.2 Optional Swivel Brackets

The BR-1 is a swivel, surface-mounted bracket which allows greater flexibility when choosing the direction at which the K-940 is pointed. The BR-1 is adjustable 30° downward and 45° left, 45° right (see Figure 3).

The BR-2 is a kit for installation in room corners. It consists of the BR-1 and a corner mounting adapter.

The BR-3 is a kit for installation on ceilings. It consists of the BR-1 and a ceiling mounting adapter.

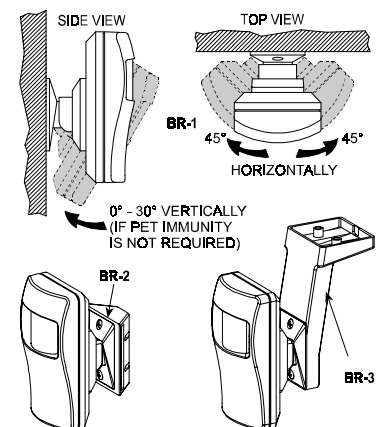

Figure 3. Optional Swivel Brackets



**CAUTION!** Tilting of the detector is not allowed in pet immune applications. The bracket should be used for **horizontal alignment only**. The detector should be kept vertical (perpendicular to the floor).

Having pointed the detector as desired, tighten the bracket screw strongly, to prevent any further change of position.

### 3.3 Wiring

Route the wires into the detector via the wiring knockouts (see Figure 2) or via the wiring channel and its associated knockout. The channel allows routing of wires from the ceiling under the base and then inside. Wire up the terminal as shown in Figure 4.

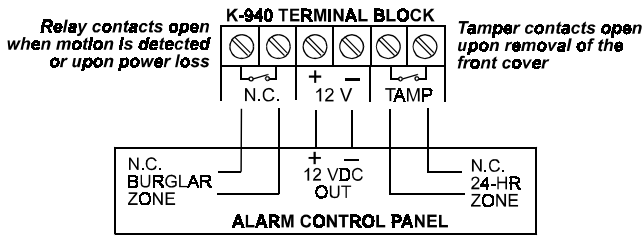

Note: The power supply must have at least 4 hours of battery backup.

Figure 4. Terminal Block Wiring

For installations in Canada, the N.C. relay must be connected to an end-of-line resistor supervised zone.

### 3.4 Vertical Adjustment

#### A. Pet-Immune Applications

To maintain maximum coverage range and pet immunity, the vertical adjustment scale must be adjusted in accordance with the actual mounting height (refer to Figure 5). Loosen the vertical adjustment screw and slide the printed circuit board up or down until the pointer shows the actual mounting height on the scale. When done, re-tighten the screw well.

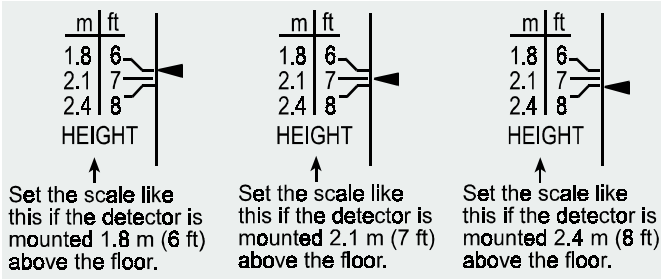

Figure 5. Vertical Adjustment

### B. Pet-Free Locations

To obtain the best coverage possible where no pets are present, mount the detector with a swivel bracket (see Para. 3.2) at any desired height between 1.8 m (6 ft) and 2.4 m (8 ft). Then set the vertical adjustment scale to the **2.4 m (8 ft) position** and use the bracket to tilt the detector 30° down.

### 3.5 The Pulse Counter

The K-940 programmable pulse counter can be set to count 1 or 3 pulses, before activating the alarm relay. To set the pulse counter, place the jumper at the desired setting (1 or 3).

**3 Pulses:** This setting provides improved protection against false alarms caused by all types of environmental disturbances.



**1 Pulse:** This setting actually disables the pulse counter. It should be used in high security installations, where the alarm must be activated on the first detected pulse.



### 3.6 Walk Testing

- Apply power and allow 5 minutes to warm up and stabilize.
- Adjust the vertical pattern angle per Para. 3.4
- Set the pulse counter per Para. 3.5.
- Walk-test the entire coverage area by walking slowly across the field of view (in opposite directions) and observing the LED. The LED will light up whenever your motion is detected. Allow 5 seconds between each test for the unit to stabilize.
 

**Note:** If the LED is disabled, you may use the control panel's visual and audible indicators to verify proper detector function.
- In pet immune applications, continue the test by sending the pet into the protected area. Make sure it **does not** trigger the detector by moving across the protected area and by climbing on furniture within that area.
- After testing, the LED can be disabled to prevent unauthorized persons from tracing the coverage pattern. To disable the LED, remove the jumper from the ON position and place it in the OFF position.

**Note:** The range and coverage area should be checked at least once a year by the installer. To assure proper continuous functioning, the user should be instructed to perform a walk test at the far end of the coverage pattern to assure an alarm signal prior to each time the alarm system is armed.

### WARRANTY

Visonic Ltd. and/or its subsidiaries and its affiliates ("the Manufacturer") warrants its products hereinafter referred to as "the Product" or "Products" to be in conformance with its own plans and specifications and to be free of defects in materials and workmanship under normal use and service for a period of twelve months from the date of shipment by the Manufacturer. The Manufacturer's obligations shall be limited within the warranty period, at its option, to repair or replace the product or any part thereof. The Manufacturer shall not be responsible for dismantling and/or reinstallation charges. To exercise the warranty the product must be returned to the Manufacturer freight prepaid and insured.

**This warranty does not apply in the following cases:** improper installation, misuse, failure to follow installation and operating instructions, alteration, abuse, accident or tampering, and repair by anyone other than the Manufacturer.

This warranty is exclusive and expressly in lieu of all other warranties, obligations or liabilities, whether written, oral, express or implied, including any warranty of merchantability or fitness for a particular purpose, or otherwise. In no case shall the Manufacturer be liable to anyone for any consequential or incidental damages for breach of this warranty or any other warranties whatsoever, as aforesaid.

This warranty shall not be modified, varied or extended, and the Manufacturer does not authorize any person to act on its behalf in the modification, variation or extension of this warranty. This warranty shall apply to the Product only. All products, accessories or attachments of others used in conjunction with the Product, including batteries, shall be covered solely by their own warranty, if any. The Manufacturer shall not be liable for any damage or loss whatsoever, whether directly, indirectly, incidentally, consequentially or otherwise, caused by the malfunction of the Product due to products, accessories, or attachments of others, including batteries, used in conjunction with the Products.

The Manufacturer does not represent that its Product may not be compromised and/or circumvented, or that the Product will prevent any death, personal and/or bodily injury and/or damage to property resulting from burglary, robbery, fire or otherwise, or that the Product will in all cases provide adequate warning or protection. User understands that a properly installed and maintained alarm may only reduce the risk of events such as burglary, robbery, and fire without warning, but it is not insurance or a guarantee that such will not occur or that there will be no death, personal damage and/or damage to property as a result.

**The Manufacturer shall have no liability for any death, personal and/or bodily injury and/or damage to property or other loss whether direct, indirect, incidental, consequential or otherwise, based on a claim that the Product failed to function.** However, if the Manufacturer is held liable, whether directly or indirectly, for any loss or damage arising under this limited warranty or otherwise, regardless of cause or origin, the Manufacturer's maximum liability shall not in any case exceed the purchase price of the Product, which shall be fixed as liquidated damages and not as a penalty, and shall be the complete and exclusive remedy against the Manufacturer.

**Warning:** The user should follow the installation and operation instructions and among other things test the Product and the whole system at least once a week. For various reasons, including, but not limited to, changes in environmental conditions, electric or electronic disruptions and tampering, the Product may not perform as expected. The user is advised to take all necessary precautions for his/her safety and the protection of his/her property.

6/91



VISONIC LTD. (ISRAEL): P.O.B 22020 TEL-AVIV 61220 ISRAEL. PHONE: (972-3) 645-6789. FAX: (972-3) 645-6788  
 VISONIC INC. (U.S.A.): 10 NORTHWOOD DRIVE, BLOOMFIELD CT. 06002-1911. PHONE: (860) 243-0833, (800) 223-0020 FAX: (860) 242-8094  
 VISONIC LTD. (UK): FRASER ROAD, PRIORY BUSINESS PARK, BEDFORD MK44 3WH. PHONE: (0870) 7300800 FAX: (0870) 7300801  
 INTERNET: www.visonic.com

©VISONIC LTD. 2001 K-940 DE1240- (REV. 2, 02/01)

