



SILENT KNIGHT

5495

Distributed Power Module

Installation Manual

Part Number 151161G, 08/03

Content

Section 1

Introduction	1
---------------------------	---

Section 2

UL Requirements	2
------------------------------	---

Section 3

System Overview	3
------------------------------	---

3.1 Terminal Descriptions and Electrical Ratings	3
3.2 Signal Input Terminals	4
3.3 Notification Appliance Circuit Terminals	5

Section 4

Installation	6
---------------------------	---

4.1 Mounting	6
4.2 Wire Routing	7
4.3 Current Requirements (Standby and Alarm)	8
4.3.1 Current Drawn From Host Panel	8
4.3.2 Current Drawn from Battery	8
4.4 Connecting the 5495 to a Control Panel	10
4.4.1 Trouble Relay	11
4.5 Notification Appliance Wiring	11
4.5.1 Class A Supervised Wiring	11
Class A Output Notification Circuits	11
Class A Supervised Input Circuits	12
4.5.2 Class B Supervised Wiring	12
Class B Output Notification Circuits	12
Class B Supervised Input Circuits	13
4.6 Ground Fault Detection Enable/Disable Jumper	13
4.7 Battery Connection	14
4.8 DIP Switch Settings	14
4.8.1 Selecting the Standard Input/Output Configurations	15
4.8.2 Selecting Synchronized Output Configurations	17
4.8.2.1 Selecting Synchronized Faraday Configurations	17
4.8.2.2 Selecting Synchronized Gentex Configurations	17
4.8.2.3 Selecting Synchronized System Sensor Configurations	18
4.8.2.4 Selecting Synchronized Wheelock Configurations	18
4.8.2.5 Selecting Synchronized AMSECO Configurations	18
4.8.3 Setting the Loss of AC Delay	19
4.8.4 Setting the Auxiliary Output	19

Section 5
Connection to Silent Knight Panels20

Section 6
Sample Applications22

6.1 Notification Power Applications22
6.2 Non-Resettable Power Application24
6.3 Door Holder Application25

Section 7
Troubleshooting26

7.1 LEDs26
7.2 Trouble Conditions27
7.3 Removing and Replacing the Control Panel28
 7.3.1 Removing the Control Panel28
 7.3.2 Replacing the Control Panel28

Appendix A
UL Listed Notification Appliances29

A.1 Notification Appliances29

Section 1

Introduction

The Model 5495 is a notification appliance circuit and auxiliary power expander that provides up to 6 amps of filtered, 24 volt power for powering notification appliances and auxiliary devices. The 5495 provides its own AC power connection, battery charging circuit, and battery connections. Used with security and fire alarm control panels, the 5495 enables you to connect and distribute power to many more devices than your panel may normally allow.

- Input Configurations

The 5495 has two optically isolated signaling inputs that provide the signal connection from the main control panel to the 5495 (see Section 3.2 for more details).

- Output Configurations

The 5495 has four power-limited notification appliance circuits that can be configured in various combinations of Class A and Class B circuits (see Section 3.3 for details).

- Auxiliary Power Configurations

The 5495 has a dedicated, power-limited, auxiliary output that can be configured in two different ways. The auxiliary output can either be non-resettable (always on), or configured to switch off during the AC power failure to conserve the battery standby power. When the auxiliary power is configured to switch off, there is a 30 second delay before the auxiliary power is turned off after the AC power fails (see Section 4.8.4 for details).

- Form C Trouble Relay

The 5495 includes a general trouble relay that will de-energize for any trouble situation. (see Section 4.4.1 for details).

- Earth Fault Detection

The 5495 monitors for earth faults to the system power or system ground. When detected, the system de-energizes the trouble relay and the input supervision relays (see Section 6.2 for details).

- ANSI Temporal Code

The 5495 provides two configuration options that will drive outputs with the ANSI temporal code if the inputs are on constantly (see Section 4.8.1 for details).

- Supports Synchronized appliances

The 5495 provides configuration options that will eliminate the need for synchronized modules when using Amseco, Faraday, Gentex, System Sensor, or Wheelock synchronization appliances.

Section 2

UL Requirements

When installed in accordance with NFPA 72 standards, the 5495 can be connected to UL Listed devices.

The 5495 is also listed to meet UL Standard 864 and power limiting requirements.

The 5495 is compatible with any UL listed control unit utilizing reverse polarity supervised notification appliance circuits, using 24 VDC regulated outputs.

Section 3

System Overview

CAUTION

Each output circuit is rated at 3 amps. DO NOT OVERLOAD. Overloading a circuit will cause it to shut down (power limit). The circuit will automatically reset once you remove the overload condition.

3.1 Terminal Descriptions and Electrical Ratings

Terminal #	Description	Ratings
TB1		
1	AC (black--“hot”)	120 VAC 60 Hz, 2A
2	Earth Ground	
3	AC (white--“neutral”)	
TB2		
1	Auxiliary Power (-)	24 VDC 3.0 amps
2	Auxiliary Power (+)	
3	Notification 4 Output (-)	24 VDC 3.0 amps
4	Notification 4 Output (+)	
5	Notification 3 Output (-)	24 VDC 3.0 amps
6	Notification 3 Output (+)	
7	Notification 2 Output (-)	24 VDC 3.0 amps
8	Notification 2 Output (+)	
9	Notification 1 Output (-)	24 VDC 3.0 amps
10	Notification 1 Output (+)	
11	Normally Closed contact	2.5 A @ 250 VAC or 2.5 A @ 30 VDC
12	Common	
13	Normally Open contact	
14	Input 2	9 - 30 VDC
15	Input 2 (-)	
16	Input 2 (+)	
17	Input 1	9 - 30 VDC
18	Input 1 (-)	
19	Input 1 (+)	

Although each output is rated for 3 amps, the total current draw from the 4 outputs and the auxiliary power must not exceed 6 amps.

3.2 Signal Input Terminals

Terminals 14 through 19 are polarized signal input terminals. They provide the signaling connection from the main panel to the 5495. See Figure 4-2 for more details.

Section 5 shows connections to specific Silent Knight fire alarm control units.

The main panel supervises its notification appliance circuits used for communicating with the 5495 the same way it supervises ordinary notification appliance circuits. The signal inputs on the 5495 monitor the polarity of the voltage coming from the main panel's notification appliance circuits to determine when to operate the notification appliance circuits on the 5495. The 5495 emulates the trouble behavior of a normal notification appliance circuit by interrupting the EOL supervision current for internal or output trouble conditions on the 5495.

Note that the 5495 will accurately sense the polarity of the main panel's notification appliance circuits to drive the outputs whether or not the supervision connection is intact. The following situations will disconnect the EOL supervision at the signal inputs and indicate a trouble condition:

- Low AC power
- Low Battery condition
- Earth ground fault to the system power or system ground
- Auxiliary output power-limited condition
- EOL supervision trouble or power-limited condition at an output

Trouble conditions will not necessarily occur for both inputs when the trouble is specific to a particular output. Only the signal input controlling the output circuit that is in trouble will indicate a trouble condition. Below are examples where both inputs do NOT indicate trouble for a trouble occurring at only one output circuit.

Example 1: If input 1 controls all four outputs, a fault on any output will cause input 1 to indicate trouble. The fault does not affect input 2.

Example 2: If input 1 controls outputs 1 and 2, and input 2 controls outputs 3 and 4, a fault condition on output 3 or 4 will cause input 2 to indicate trouble. The fault does not affect input 1.

Note: *Once the inputs are driven with forward polarity to activate the outputs, the main control panel will not be able to sense trouble conditions through its notification appliance circuit connected to the 5495 input circuits. Use the 5495 trouble relay when it is necessary to monitor trouble conditions and active alarm conditions at the same time.*

Section 7 explains the significance of each trouble condition in more detail.

3.3 Notification Appliance Circuit Terminals

Terminals 3 through 10 are the notification appliance circuit output terminals. Each of the four circuits are rated at 3 amps, although you can only draw a total of 6 amps from the 5495. The 5495 outputs are short-circuit protected (power limited) according to UL 864 standards. Overcurrent indicators are yellow LEDs. The output voltage can vary depending on the load and input voltage.

The four power-limited NAC outputs can be configured as follows:

- Four Class B circuits
- Two Class A circuits
- One Class A and two Class B circuits
- Class B, ANSI temporal-coded circuits
- Faraday synchronized outputs
- Gentex synchronized outputs
- System Sensor synchronized outputs
- Wheelock synchronization outputs
- AMSECO synchronized outputs

One or both 5495 signal inputs control the NAC outputs, depending on the specific configuration setup. Possible configurations for the 5495 are:

For Option:	These Inputs:	Control These Outputs:	As:
1	Input 1	All outputs	Class B circuits
2	Input 1 or Input 2	Outputs 1, 2, 3, and 4	Class B ANSI temporal-coded circuits
3	Input 1 Input 2	Outputs 1 and 2 Outputs 3 and 4	Class B circuits Class B circuits
4	Input 1 Input 2	Output 1 Outputs 2, 3, and 4	Class B circuits Class B circuits
5	Input 1	Outputs 1-2 and 3-4	Class A circuit pairs
6	Input 1 Input 2	Outputs 1 and 2 Outputs 3 and 4	Class B ANSI temporal-coded circuits Class B circuits
7	Input 1 Input 2	Outputs 1-2 Outputs 3-4	Class A circuit pair Class A circuit pair
8	Input 1 Input 2	Outputs 1-2 Outputs 3 and 4	Class A circuit pair Class B circuits
9	Input 1 (Strobe Control) Input 2 (Audio Control)	All outputs	Class A or Class B Faraday Sync. Output
10	Input 1 (Strobe Control) Input 2 (Audio Control)	All outputs	Class A or Class B Gentex Sync. Output
11	Input 1 (Strobe Control) Input 2 (Audio Control)	All outputs	Class A or Class B System Sensor Sync. Output
12	Input 1 (Strobe Control) Input 2 (Audio Control)	All outputs	Class A or Class B Wheelock Sync. Output
13	Input 1 (Strobe Control) Input 2 (Audio Control)	All outputs	Class A or Class B Amseco Sync. Output

You can select which input controls which output, and which inputs are Class A and Class B using the 7-position DIP switch on the printed circuit board. Section 4.8 for DIP switch settings.

Section 4

Installation

Before installing the 5495, the AC input must first be wired into the building's main electrical power through the TB1 terminals (see Figure 4-2). Shut off the electrical power to the 5495, and then complete the general installation of the 5495 using the information in this section.

4.1 Mounting

Mount the 5495 in locations that meet the following temperature and humidity requirements. Do not expose the panel to conditions outside these ranges.

Temperature	0° C-49° C (32° F-120° F)
Humidity	10%-85% at 30° C (86° F) noncondensing

When mounting on interior walls, use appropriate screw anchors in plaster. When mounting on concrete, especially when moisture is expected, first attach a piece of 3/4-inch plywood to the concrete surface. Attach the 5495 to the plywood.

4.2 Wire Routing

To avoid induced noise (transfer of electrical energy from one wire to another), keep input wiring isolated from high current output and power-limited wiring. Induced noise can interfere with telephone communication or even cause false alarms. Avoid pulling a single multiconductor cable for the entire system. Instead, separate high current input/output from low current. Separate power-limited from non-power-limited wiring. Non-power-limited wiring must be enclosed in conduit.

Wiring within the cabinet should be routed around the perimeter of the cabinet. It should not cross the printed circuit board where it could induce noise into the sensitive microelectronics or pick up unwanted RF noise from the switching power supply circuit.

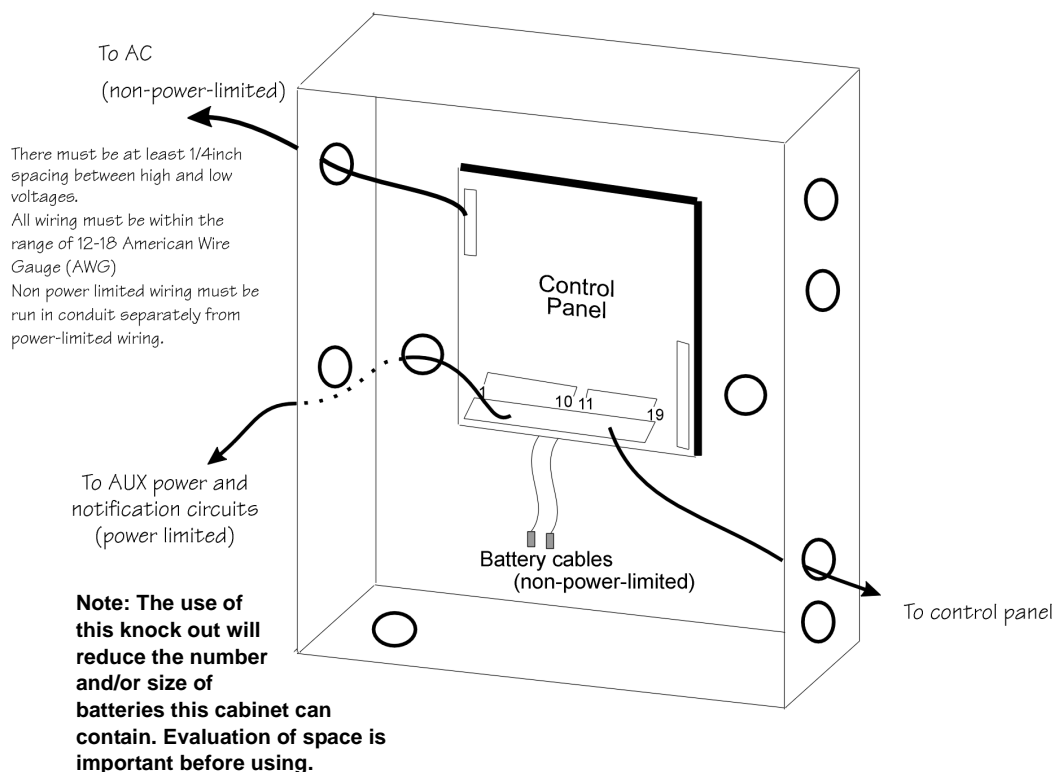

Figure 4-1 Sample Wire Routing

4.3 Current Requirements (Standby and Alarm)

4.3.1 Current Drawn From Host Panel

Table 4-1 shows the 5495 current draw requirements from the main control panel when the panel's notification appliance circuit is in alarm. The current draw from the main panel when it is supervising the 5495 is the same current draw that would be present when the main panel supervises an ordinary notification appliance circuit.

Table 4-1: Alarm Current Drawn From Main Control Panel

	Panel Voltage	Current
Alarm Current (for typical voltages) drawn from main panel's notification appliance circuits.	12 VDC	6.5 mA
	24 VDC	One input circuit: 15 mA
		Both input circuits: 30 mA

4.3.2 Current Drawn from Battery

Batteries used with the 5495 must not exceed 33 AH, such as. Batteries larger than 7 AH will not fit into the 5495 cabinet and must be housed in the AB-33 Accessory Battery Cabinet. See Section 4.7 for battery installation.

The following is the maximum current draw from the auxiliary power terminals for standby calculations. These currents assume 24 or 60 hours of standby time, followed by 5 minutes of maximum alarm current.

- 195 mA for 24 Hour Standby Current
- 39 mA for 60 Hours of Auxiliary Standby Current

The above numbers were calculated assuming the use of 7 AH batteries at 100% of rated capacity.

The total current of the 5495, plus all items powered from it, must not exceed 6 A when the panel is in alarm. Use Table 4-2 to ensure that the current does not exceed 6 A and, that the desired amount of standby is possible for the battery intended for use with the 5495.

Table 4-2: Battery Calculation Worksheet

	Device	Number of Devices	Current per Device		Standby Current	Alarm Current	
	<i>For each device use this formula:</i>	<i>This column</i>	<i>X</i>	<i>This column</i>	<i>=</i>	<i>Current per number of devices.</i>	
	5495 Distributed Power Module (Current draw from battery)	1	Standby:	75 mA	75 mA		
			Alarm:	175 mA		175 mA	
A	5495 Current				75 mA	175 mA	
	Auxiliary Devices	<i>Refer to device manual for current ratings.</i>					
			Alarm/Standby	mA	mA	mA	
			Alarm/Standby	mA	mA	mA	
			Alarm/Standby	mA	mA	mA	
			Alarm/Standby	mA	mA	mA	
B	Auxiliary Device Current				mA	mA	
	Notification appliances	<i>Refer to device manual for current ratings.</i>					
			Alarm:	mA	0 mA	mA	
			Alarm:	mA	0 mA	mA	
			Alarm:	mA	0 mA	mA	
			Alarm:	mA	0 mA	mA	
C	Notification Appliance Current				0 mA	mA	
D	Total current ratings of all devices in system (line A + line B + line C)				mA	mA	
E	Total current ratings converted to amperes (line D x .001):				A	A	
F	Number of standby hours (24 or 60 for NFPA 72, Chapter 1, 1-5.2.5).				H		
G	Multiply lines E and F. Total standby AH				AH		
H	Alarm sounding period in hours. (For example, 5 minutes = .0833 hours.)					H	
I	Multiply lines E and H. Total alarm AH					AH	
J	Add lines G and I. Total standby and alarm AH				AH		
K	Multiply line J by 1.20. (20% extra insurance to meet desired performance) Total ampere-hours required				AH		

4.4 Connecting the 5495 to a Control Panel

Figure 4-2 shows the general layout of the 5495 PC board. This section also provides specific wiring details for accessories.

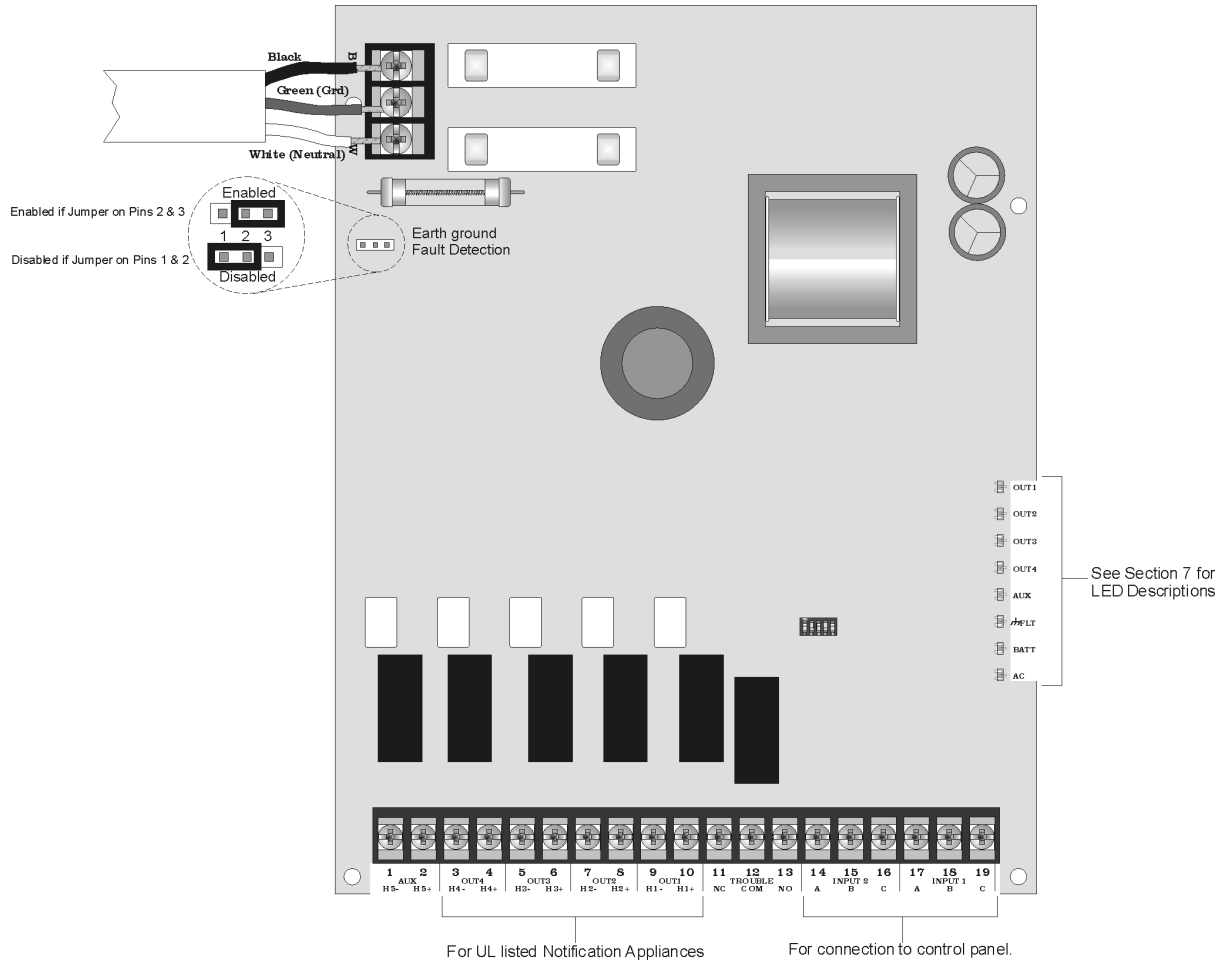

Figure 4-2 The Model 5495 PC Board Layout

Consult the installation manual for specific wiring information for the control panel being used. If you are using a Silent Knight control panel, see Section 5 for connections.

4.4.1 Trouble Relay

The 5495 has a Form C trouble relay built into Terminals 11-13. The relay provides a normally open and a normally closed contact, both of which are rated at 2.5A. The trouble relay will deactivate under any trouble condition.

A typical application of the trouble relay is to connect the 5495 normally closed (N.C.) contacts in series with the EOL supplied with the fire alarm control panel. This will cause a trouble on the fire alarm control panel when the 5495 opens its trouble contacts.

Note: The N.C. contact is the contact that is closed when the 5495 has power and there are no trouble conditions.

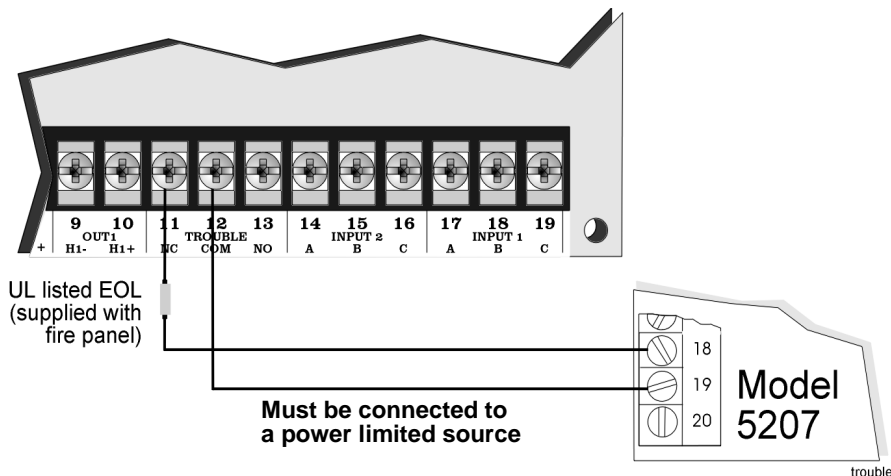

Figure 4-3 Trouble Relay Connection Example

4.5 Notification Appliance Wiring

Note: Not all devices can use the sync feature. Be sure to check Table A-1 Appendix A to ensure the device you have chosen will work with this feature.

4.5.1 Class A Supervised Wiring

Figure 4-4 shows how to wire for Class A input and output supervision. Use in/out wiring methods for proper supervision. (Refer to the Appendix for notification appliances compatible with the 5495.)

Class A Output Notification Circuits

The configuration shown in Figure 4-4 shows two, 3 A devices wired as Class A. When using the outputs as Class A circuits, loop the wiring back to the corresponding circuit pair. For Class A wiring, no external EOL is necessary since it is built into the 5495 board.

Class A Supervised Input Circuits

The configuration shown in Figure 4-4 shows Class A supervised wiring from a fire alarm control panel to the Model 5495 board. Pay close attention to the polarities when wiring a panel to the 5495 and follow these requirements:

- When wiring to Terminal 18 on the 5495, you must use two separate wires. Do not loop a single wire or twist two conductors together.
- Do not use notification appliances on Class A circuits connected to a 5495 for input. The 5495 will detect voltage across the input circuits, but is not designed to pass the added current load from notification appliances.

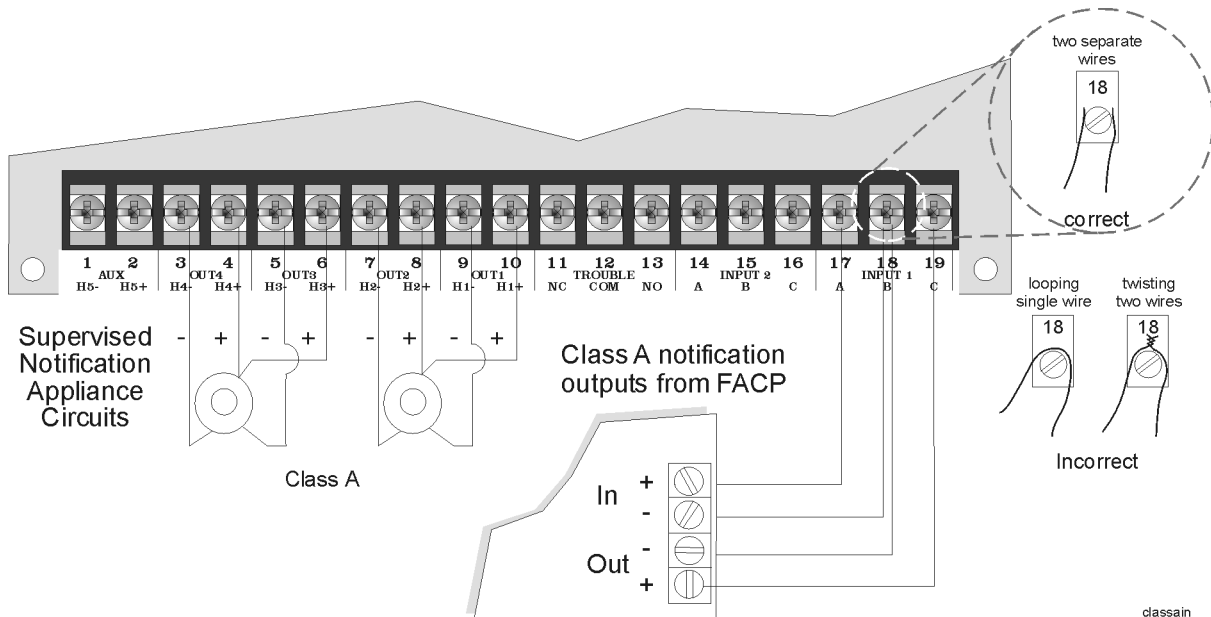

Figure 4-4 Class A Supervised Input/Output Connections

4.5.2 Class B Supervised Wiring

Figure 4-5 shows how to wire for Class B input and output supervision. Use in/out wiring methods for proper supervision (Refer to the Appendix for notification appliances approved for use with the 5495.)

Class B Output Notification Circuits

Figure 4-5 shows four, 1.5 A devices wired as Class B.

Place a 4.7k ohm EOL resistor (provided) at the end of each circuit to enable supervision when using all outputs as Class B notification appliance circuits. The 4.7k EOLs must be wired to the terminals whether or not you are using all output terminals.

Class B Supervised Input Circuits

Figure 4-5 shows Class B supervised wiring from a fire alarm control panel to the Model 5495.

Use an EOL resistor as shown to enable notification appliance circuit input supervision. Some panels use EOLs that have a different value from the 4.7k ohm EOL resistor used by the 5495. In this case, the EOL must be UL listed for the fire alarm control panel (not the 5495).

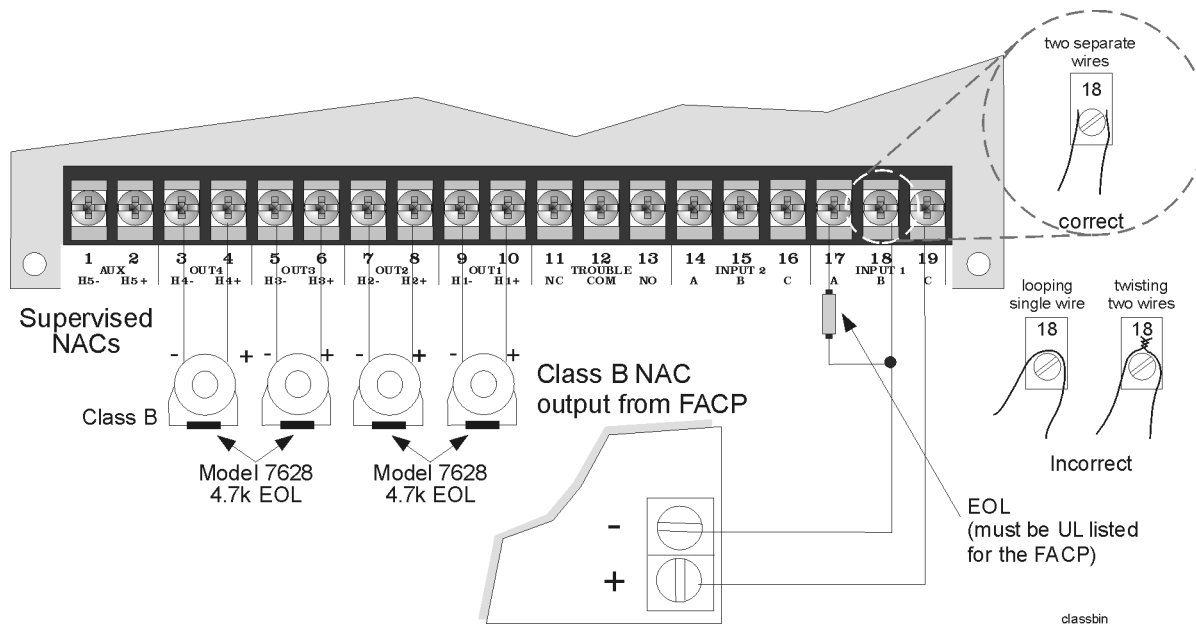

Figure 4-5 Class B Supervised Input/Output Connections

4.6 Ground Fault Detection Enable/Disable Jumper

In some cases the ground fault detection feature on the 5495 may interfere with the ground fault detection feature of the main control panel in the system. To disable the ground fault detection feature on the 5495, place the jumper block on J1, across Pins 1 and 2 (see Figure 4-2).

4.7 Battery Connection

You must use two 12 volt batteries with the 5495. Use two 12 VDC, 7 AH gel cell batteries in series, such as the, inside the 5495 cabinet. For batteries larger than 7 AH (not to exceed 33 AH)use AB-33 Accessory Battery Cabinet. It is recommended that you replace the batteries every five years. The following steps and diagram explain how to connect the batteries.

1. Connect the black wire to the negative (-) side of Battery #1.
2. Connect the jumper wire provided (P/N 140694) from the positive (+) side of Battery #1 to the negative side of Battery #2.
3. Connect the red wire to the positive (+) side of Battery #2.

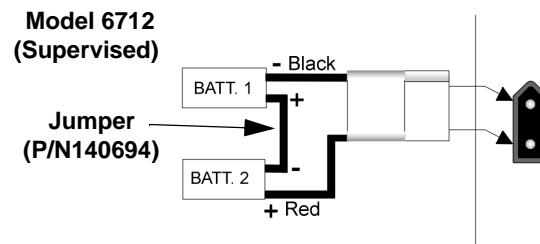

Figure 4-6 Battery Connection

4.8 DIP Switch Settings

A 7-position DIP switch on the 5495 board allows you to select the following:

- How long the 5495 will wait before indicating a loss of AC.
- Which input (Input 1 or Input 2) will control the NACs.
- Which NACs to wire as Class A and Class B.
- Auxiliary power state.
- Which NACs to operate as steady, ANSI temporal, or sync. outputs

Refer to Figure 4-2 for the location of the DIP switch on the 5495 board.

4.8.1 Selecting the Standard Input/Output Configurations

Figure 4-7 and Figure 4-8 show the position of each switch for the non-synchronized input and output configurations. The position of Switches 4 and 5 does not affect the relationship of inputs to outputs.

Note: The 5495 checks switches 1, 2, 3, and 6 only when powering up the 5495. If you change these switch settings, you must remove both the AC power and the battery to make the 5495 recognize the new settings.

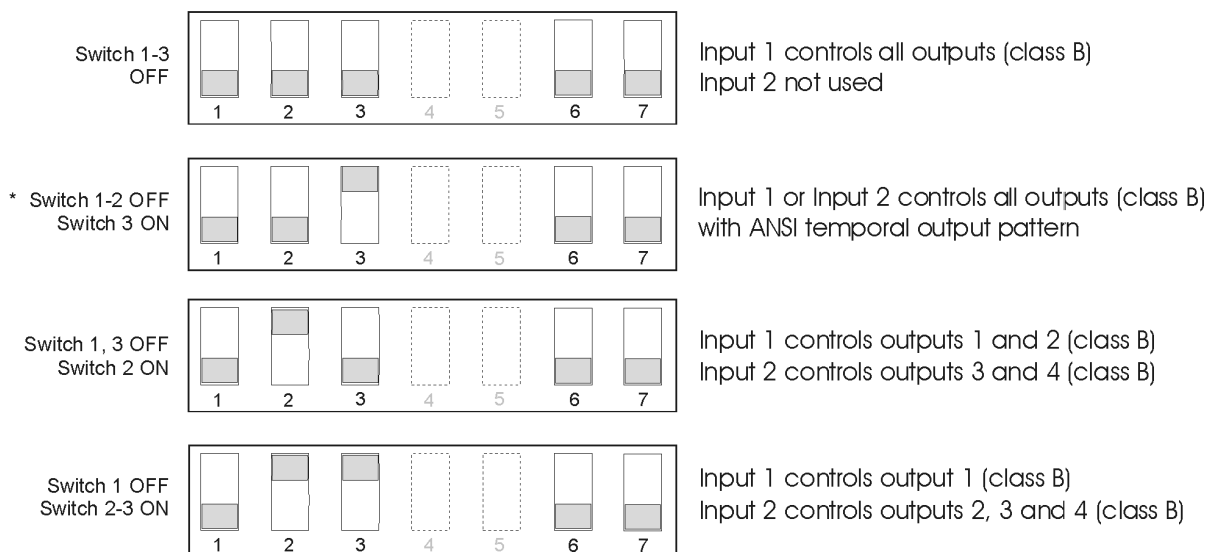

* See the following information about ANSI temporal-coded outputs

Figure 4-7 Setting DIP Switches 1-3

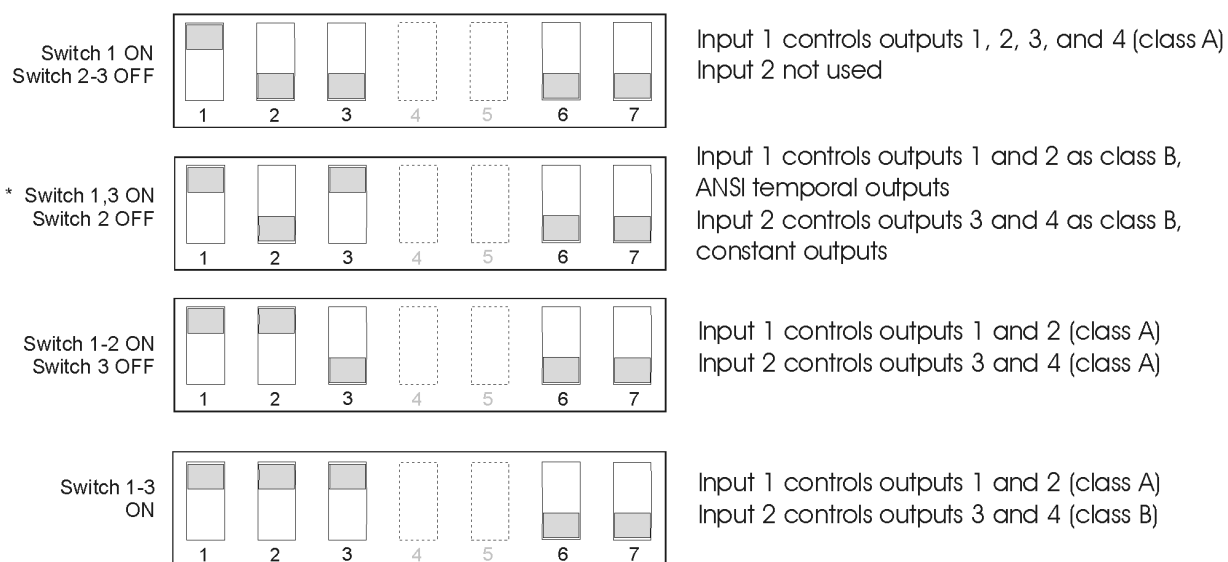

* See the following information about ANSI temporal-coded outputs

Figure 4-8 Setting DIP Switches 1-3 (Continued)

Special Note for Input/Output Configurations That Select ANSI Temporal-Coded Outputs

The DIP switch settings marked with an asterisk (*) in Figure 4-7 and Figure 4-8 are designed to produce ANSI temporal-coded outputs from a constant input. The figures shown below compare the output patterns of configurations before and after the addition of this feature.

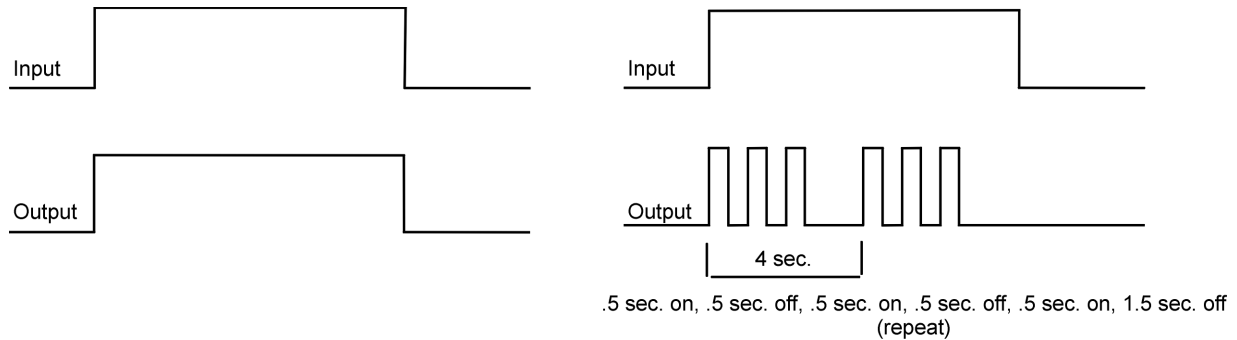

Standard 5495 Input to Output Relationship

Input/Output Relationship for ANSI Temporal-coded Options

With this new feature, a steady signal can produce the pattern shown above for panels not previously able to do so.

Note: *The 5495 can also produce temporal patterns if the inputs are non-ANSI temporal configurations.*

4.8.2 Selecting Synchronized Output Configurations

The following sections describe how to configure the 5495 as a synchronization power expander for Amseco, Faraday, Gentex, System Sensor, or Wheelock synchronized horn/strobe appliances.

Note: In order for the synchronization feature to operate properly, make sure you have set the DIP switches for the proper manufacturer. See Sections 4.8.2.1, 4.8.2.2, or 4.8.2.3.

Important!

For all synchronization options, input 1 is the strobe input and input 2 is the audible input. The signals to input 1 and input 2 must be DC signals for the synchronization patterns to work properly. When it is desired to activate both strobes and audibles, input 1 and input 2 must be active. If it is desired to only activate strobes, then input 1 must be active and input 2 must be inactive. The audible can be deactivated and reactivated at any time by changing the signal at input 2 as long as input 1 remains active. If input 1 is not active, then input 2 is ignored.

4.8.2.1 Selecting Synchronized Faraday Configurations

To select the input/outputs for Faraday synchronized appliances, set the DIP switches as shown in Figure 4-9.

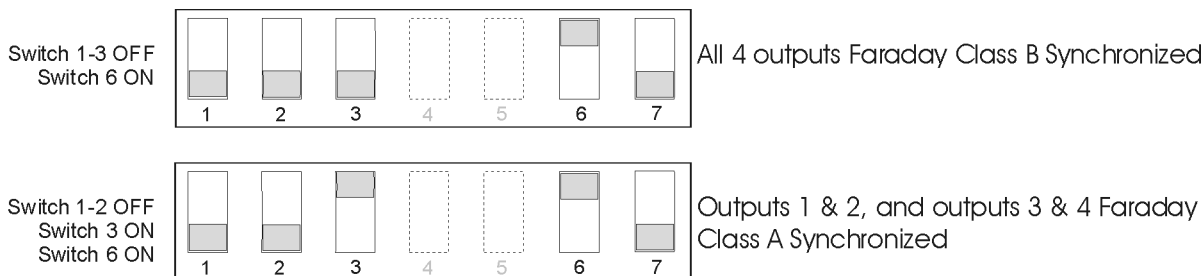

Figure 4-9 Faraday Synchronized Configurations

4.8.2.2 Selecting Synchronized Gentex Configurations

To select the input/outputs for Gentex synchronized appliances, set the DIP switches as shown in Figure 4-10.

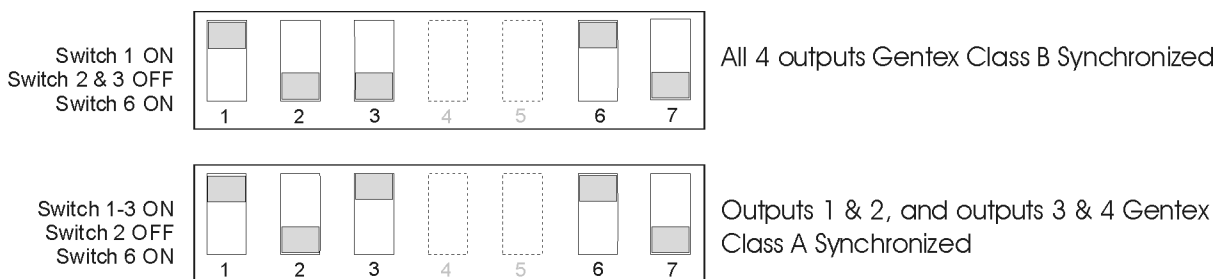

Figure 4-10 Gentex Synchronized Configurations

4.8.2.3 Selecting Synchronized System Sensor Configurations

To select the input/outputs for System Sensor synchronized appliances, set the DIP switches as shown in Figure 4-11.

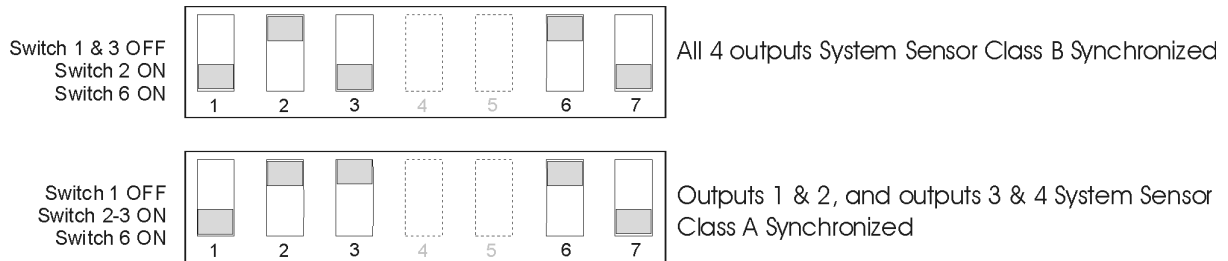

Figure 4-11 System Sensor Synchronized Configurations

4.8.2.4 Selecting Synchronized Wheelock Configurations

To select the input/outputs for Wheelock synchronized appliances, set the DIP switches as shown in Figure 4-12.

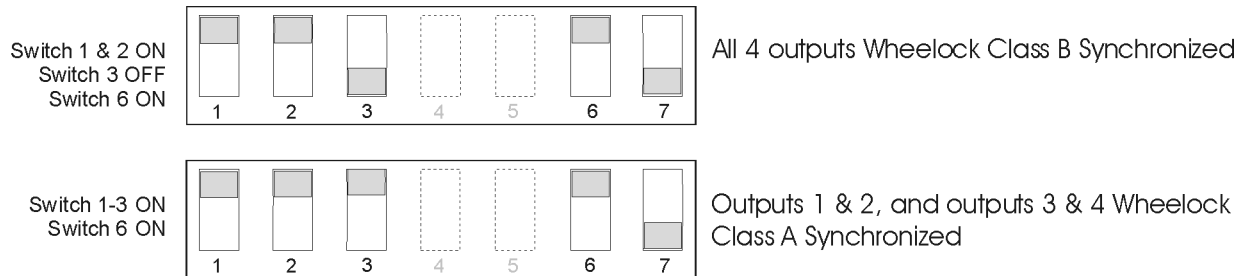

Figure 4-12 Wheelock Synchronized Configurations

4.8.2.5 Selecting Synchronized AMSECO Configurations

To select the input/outputs for AMSECO synchronized appliances, set the DIP switches as shown in Figure 4-13.

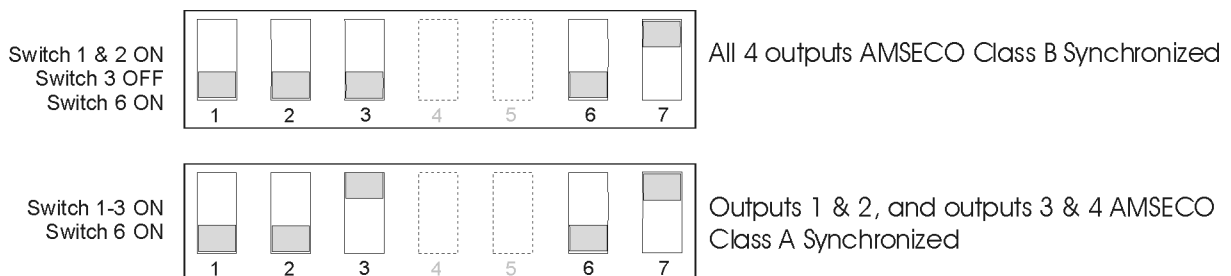

Figure 4-13 AMSECO Synchronized Configurations

4.8.3 Setting the Loss of AC Delay

Normal selection for reporting loss of AC is 6 hours.

The ON position is for test purposes only and the normal position for Switch 4 is OFF. For testing the Low AC reporting, you can temporarily turn Switch 4 ON without removing power.

Note: Remember to turn the switch OFF when testing is complete.

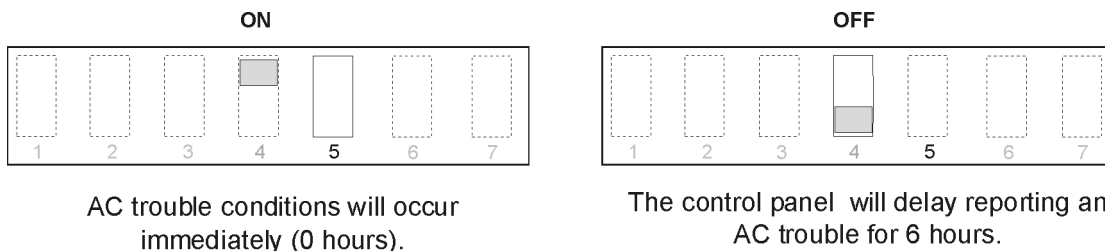

Figure 4-14 Setting DIP Switch 4

4.8.4 Setting the Auxiliary Output

Switch 5 on the DIP switch determines how the auxiliary power operates on the 5495.

The 5495 checks Switch 5 only when powering up the 5495. If you change this switch, you must remove both the AC power and the battery to force the 5495 to recognize the new switch setting.

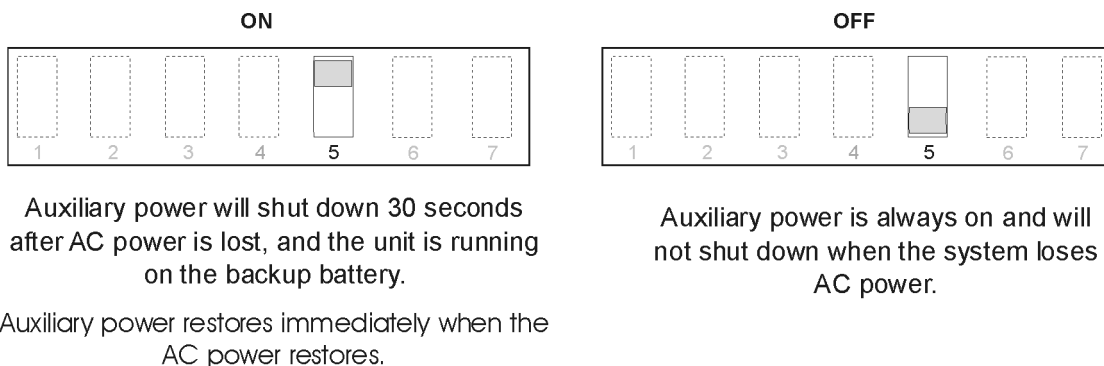

Figure 4-15 Setting DIP Switch 5

Section 5

Connection to Silent Knight Panels

The drawings in this section show you how to connect the 5495 to compatible Silent Knight panels. See panel installation manuals for more information.

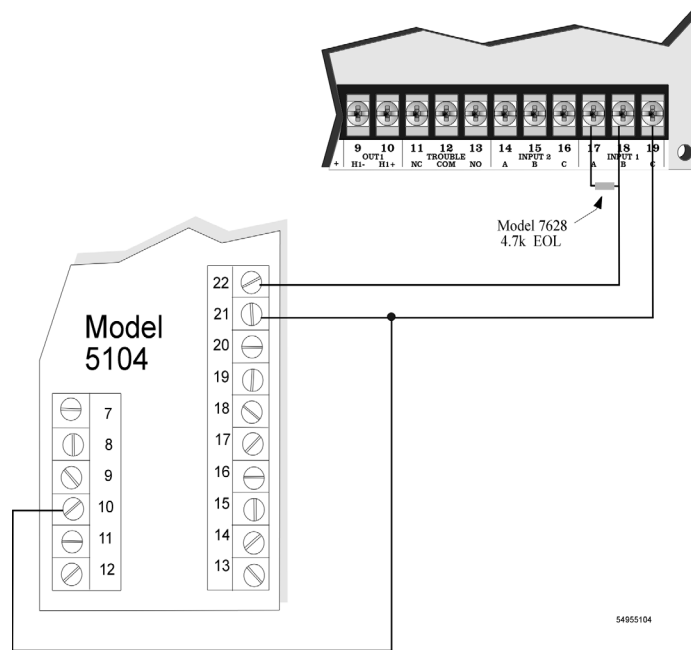

Figure 5-1 Connection to 5104 Fire Communicator

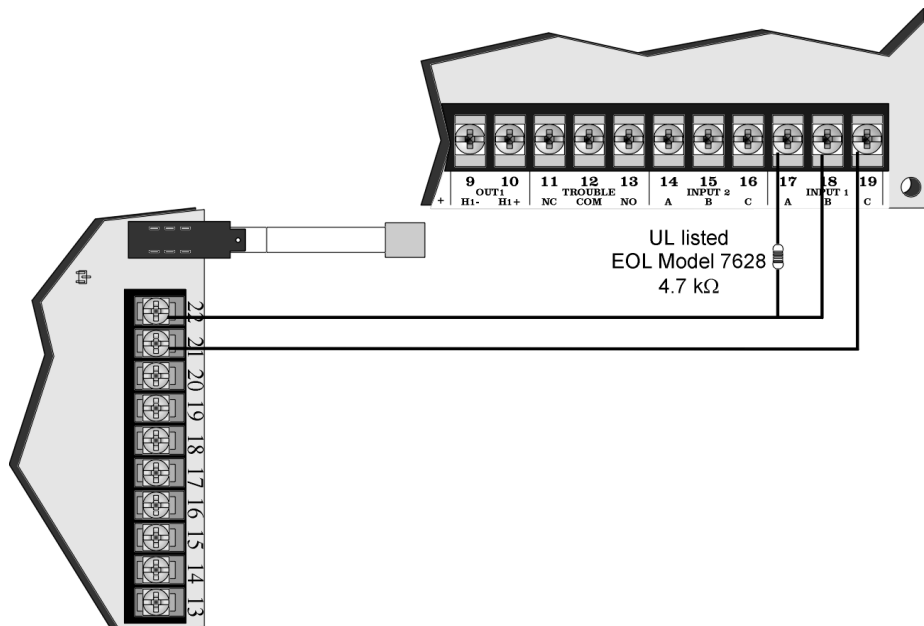

Figure 5-2 Connection to 5104B Fire Communicator

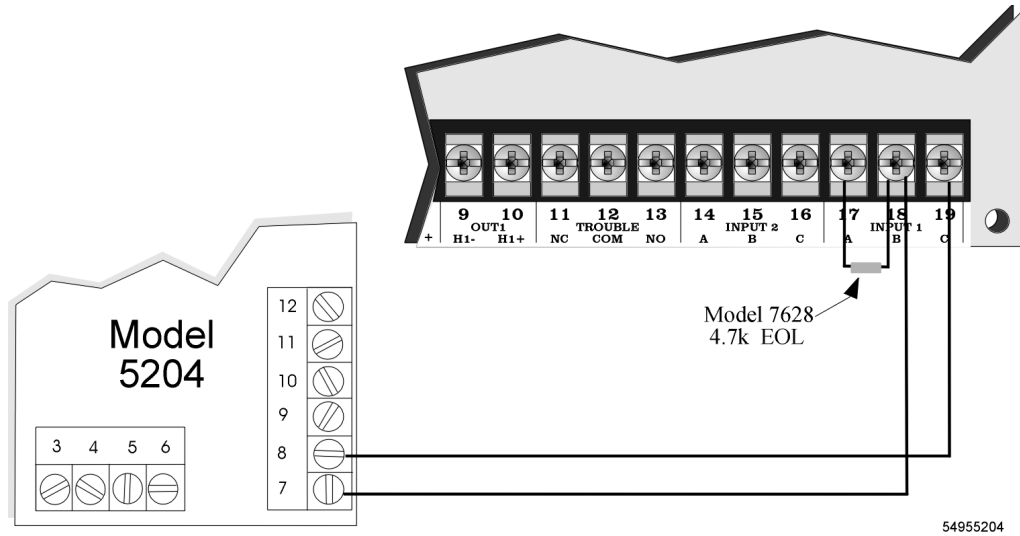

Figure 5-3 Connection to 5204 Fire Control/Communicator

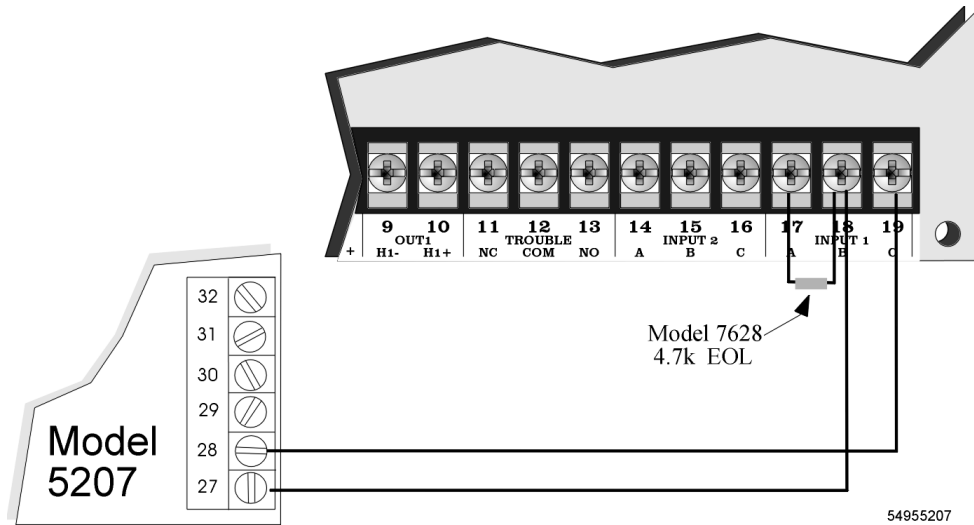

Figure 5-4 Connection to 5207 Fire Control/Communicator

Section 6

Sample Applications

The drawings in this section show various 5495 configurations, including “daisy-chaining”.

6.1 Notification Power Applications

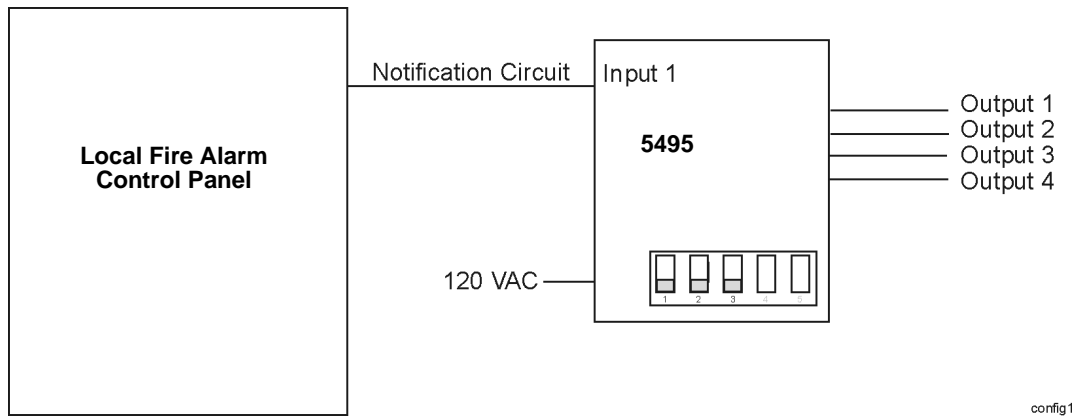

Figure 6-1 Input 1 Activates All Four Outputs

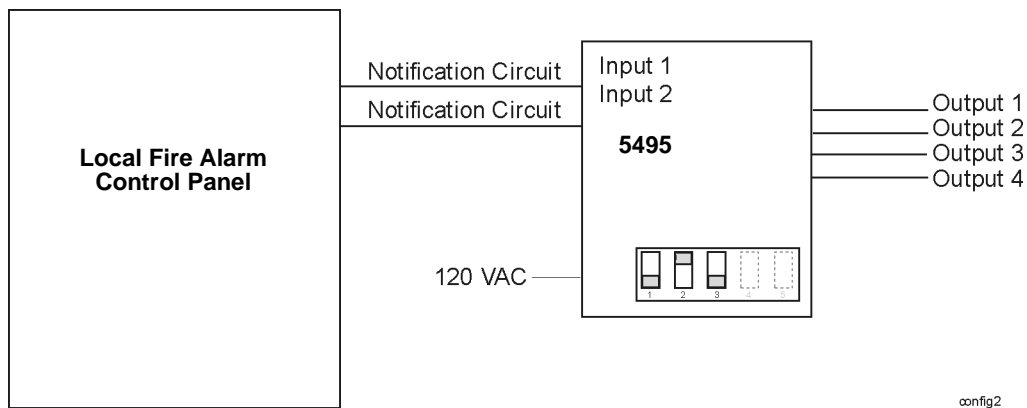

Figure 6-2 Input 1 Activates NACs 1 and 2; Input 2 Activates NACs 3 and 4

Note: When multiple power supplies are used with one control unit they will not sync with each other

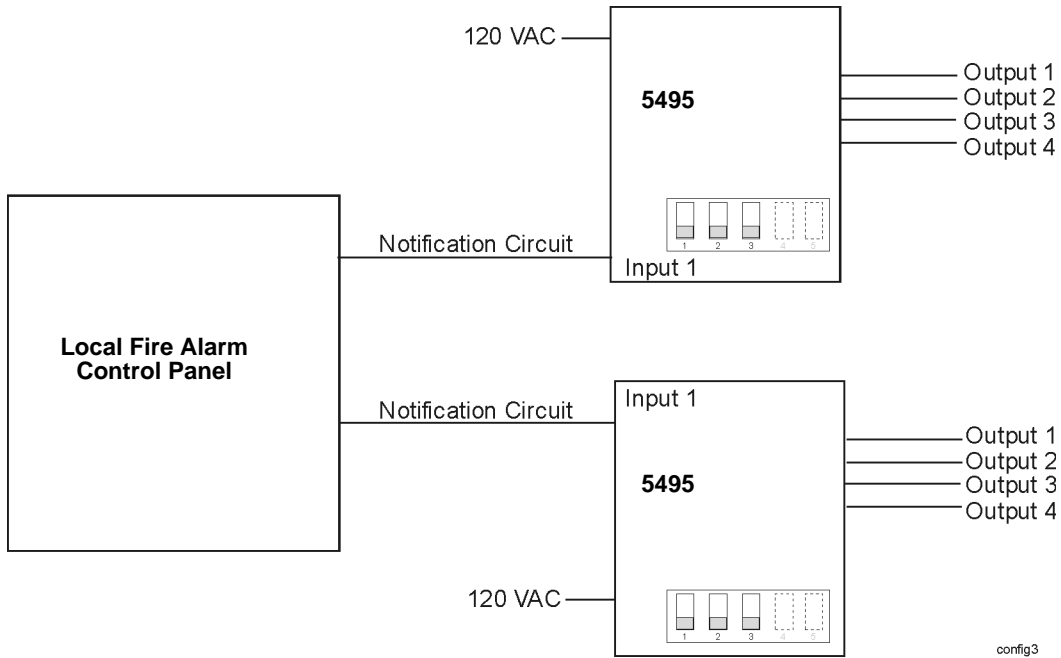

Figure 6-3 One Control Activating Two 5495s

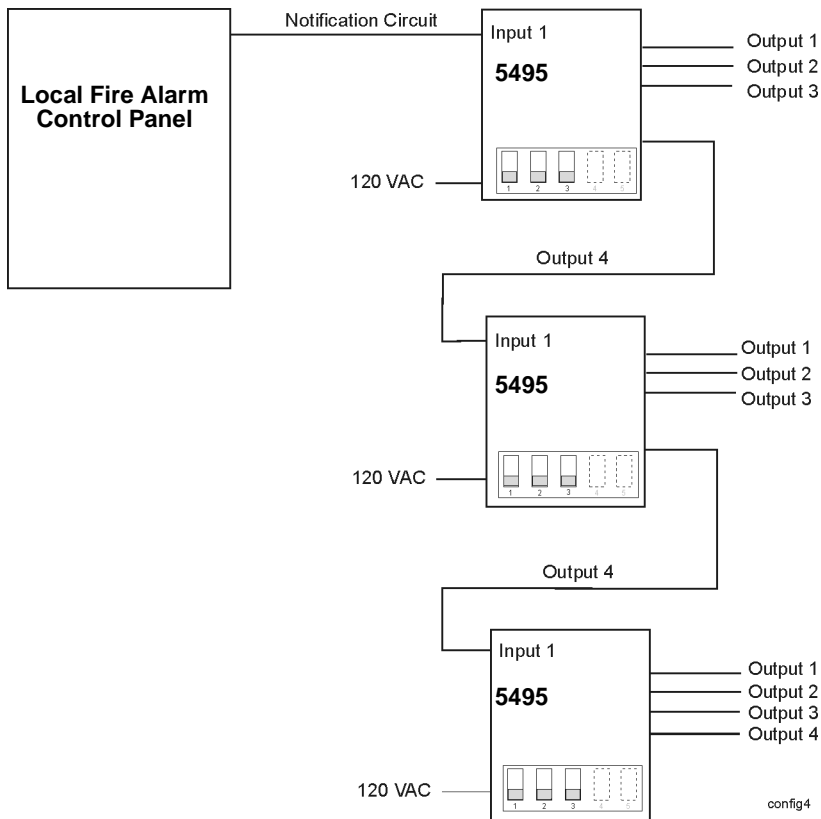

Figure 6-4 One Control Activating Three 5495s in Series

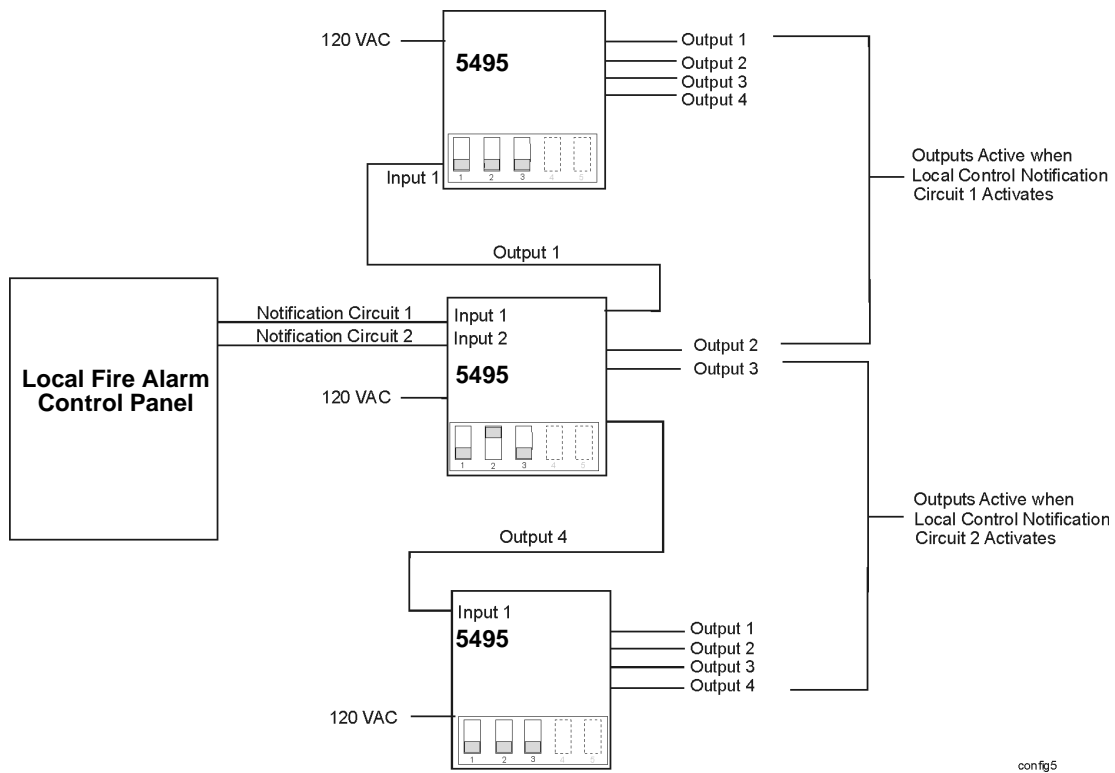
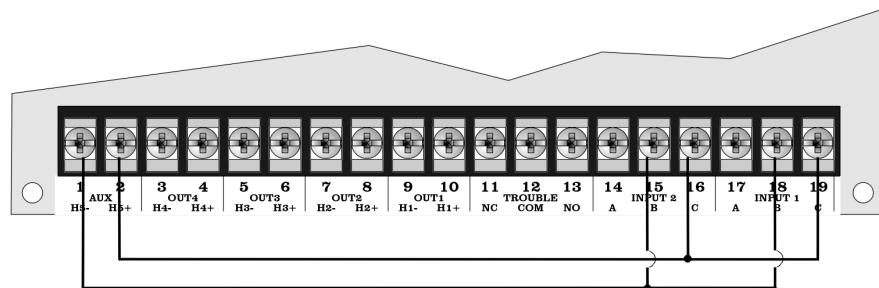

Figure 6-5 Each Control NAC Activates Five Output NACs

6.2 Non-Resettable Power Application

The 5495 provides a dedicated 3 A auxiliary power output that you can select as non-resettable (output is always on). See Section 4.8.4 for setting the auxiliary power. If you need more than 3 A, wire the inputs as shown in Figure 6-6.

This wiring provides up to 6 amps (max.) of continuous, non-resettable power (distributed among the four outputs).



Note:
maximum current is 3 amps per output.

All four outputs will be non-resettable power.
Supervise trouble conditions using the trouble relay.

reset

Figure 6-6 Auxiliary Output Wiring for Non-Resettable Power

6.3 Door Holder Application

In a typical door holder application, the door holder power must be interrupted to close all fire doors under the following conditions:

- Any active alarm condition.
- AC power failure (to conserve battery power).

To close the fire doors in these situations, wire an N.C. programmable relay from the FACP in series with the auxiliary power to the door holders as shown in Figure 6-7.

The circuit shown in Figure 6-7 will provide up to 3 amps of door holder power. (See Section 6.2 if you need more than 3 amps of auxiliary power.) The power in this example is released when AC power is off for 30 seconds or more, or when the relay from the fire alarm control panel becomes open. You would have to use the equivalent of a programmable relay from a fire alarm control panel that is programmed to open under alarm conditions. See Section 4.8.4 for selecting auxiliary power options.

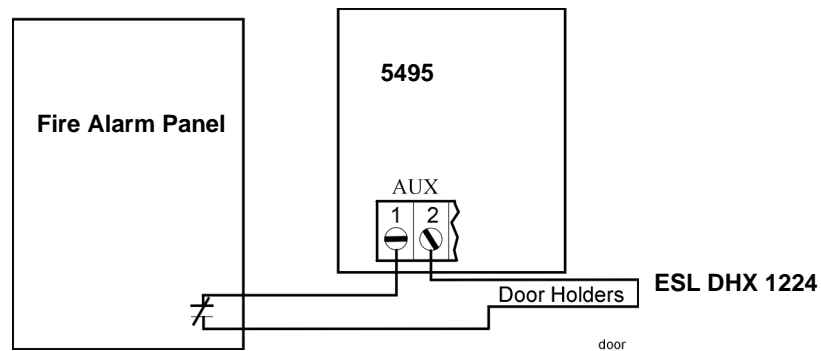

Figure 6-7 Door Holder Wiring Example

Section 7

Troubleshooting

Light-emitting diodes (LEDs) indicate fault conditions. This section describes the LED states.

7.1 LEDs

The eight LEDs indicate a fault in one of the circuits (either NACs 1 through 4, auxiliary power, earth fault, low AC, or battery). A fault in the LED's corresponding circuit will light the LED (labeled on the board). Their functions are as follows:

LED	Color	Description
OUT1	Yellow	When ON, output circuit 1 is in trouble or in an overcurrent state.
OUT2	Yellow	When ON, output circuit 2 is in trouble or in an overcurrent state.
OUT3	Yellow	When ON, output circuit 3 is in trouble or in an overcurrent state.
OUT4	Yellow	When ON, output circuit 4 is in trouble or in an overcurrent state.
AUX	Yellow	When ON, the auxiliary power output is in an overcurrent state.
FLT	Yellow	When ON, an earth ground fault on the unit exists.
BATT	Yellow	When ON, a low battery condition exists.
AC	Green	When OFF, there is no AC power to the unit. Under normal conditions, this LED is ON to indicate the presence of AC power.

See Figure 4-2 for locations of LEDs.

7.2 Trouble Conditions

Trouble Condition	What Happens
<p>Low AC (AC input voltage is low or off for 6 hours or longer.)</p>	<p>Input 1 and Input 2 supervision circuits open after a 6 hour delay. The green AC LED turns off as soon as low AC or loss of AC occurs (does not wait 6 hours). The trouble relay is de-energized after a 6 hour delay. The trouble restores within 1 minute of the AC voltage restoring to a normal level.</p>
<p>Low Battery (Battery voltage is less than 21.4 VDC.)</p>	<p>Input 1 and Input 2 supervision circuits open. The yellow "BATT" LED lights. The trouble relay is de-energized. The trouble restores when battery voltage is greater than 22.4 VDC.</p>
<p>Earth Ground Fault (The earth terminal is connected to one of the positive or negative terminals on the output or auxiliary output circuits.)</p>	<p>Input 1 and Input 2 supervision circuits open. The yellow "FLT" LED lights. The trouble relay is de-energized. The trouble restores when the fault between the earth ground and one of the output circuit terminals is removed.</p>
<p>Power Limit At AUX (Current draw at the auxiliary power terminals is exceeding 3.0 amps.)</p>	<p>Power disconnects at the AUX terminal. The yellow "AUX" LED lights. The trouble relay is de-energized. The trouble restores when the overcurrent condition no longer exists. When a circuit goes into a power limited state, it will reverse the polarity of the voltage at the terminals and verify the load. If it is more than 1k ohms, the power limit will self-restore. This does not automatically occur for some devices typically connected to auxiliary power. Power limit conditions do not restore in reverse polarity monitoring if the devices are not polarized (for example, some door holder devices). To allow automatic restores for power-limited auxiliary circuits, it is recommended that all non-polarized devices be polarized using a diode in series with each device.</p>
<p>Power-limited OUTPUT (Current draw at an output terminal is exceeding 3.0 amps.)</p>	<p>Power at the OUTPUT is disconnected. The corresponding yellow LED lights. The trouble relay is de-energized. The trouble restores when the overcurrent condition no longer exists.</p>
<p>EOL supervision trouble (Equivalent resistance of the EOL resistor is outside the range 2k - 10k.)</p>	<p>Input 1 and Input 2 supervision circuits open. Corresponding yellow LED lights. The trouble relay is de-energized. Trouble restores if an EOL within (2k-10k) appears at the output terminals.</p>

7.3 Removing and Replacing the Control Panel

This section provides instruction on how to remove and replace the control panel if it is determined that the control panel needs to be repaired or replaced.

7.3.1 Removing the Control Panel

Follow these step to properly remove the control panel:

1. Remove the two heat sink screws. The heat sink screws are located on the top of the cabinet. See Figure 7-1.

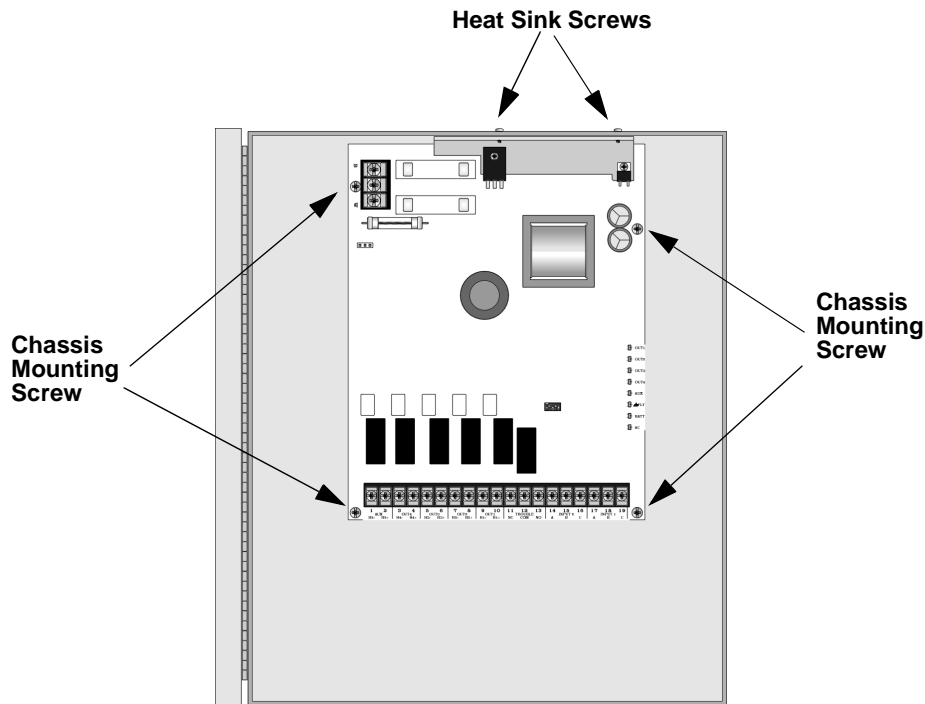

Figure 7-1 Mounting Screw Locations

2. Remove the four chassis mounting screws. See Figure 7-1 for chassis screw locations.
3. Carefully remove the control panel.

7.3.2 Replacing the Control Panel

Follow these steps to replace the control panel:

Note: Use a grounding strap when working with static sensitive components.

1. Align the control panel with the chassis mounting stand-offs. See Figure 7-1.
2. Insert the four chassis mounting screws (see Figure 7-1). Do not over tighten the chassis mounting screws.
3. Insert the two heat sink screws (see Figure 7-1). Do not over tighten the heat sink screws.

Note: The heat sink screws must be installed for proper heat dispersion of the power module's power supply.

Appendix A

UL Listed Notification Appliances

For proper operation, you must use polarized devices with a Model 7628 4.7k ohm EOL resistor on each circuit. All supervised notification appliances used with the 5495 must be polarized.

Note: Not all devices can use the Sync feature, be sure to check Table A-1 to ensure the device you have chosen will work with this feature.

A.1 Notification Appliances

Table A-1 below lists notification appliances compatible with the 5495. Appliances which can be synchronized are indicated in the column marked Sync.

Table A-1: Compatible Notification Appliances

Manufacturer	Model	Sync	Type
AMSECO	SH24W-153075	✓	Horn/Strobe
	SL24W-153075	✓	Strobe
	H24W	✓	Horn
Faraday	446		Vibrating Bell
	476		Vibrating Bell
	477		Single Stroke Bell
	2700 -M, -R, -T, -Y, -Z	✓	Strobe
	2701 Series	✓	Strobe
	2705 Series	✓	Strobe
	2820	✓	Sync Temporal Horn/Strobe
	2821	✓	Sync Temporal Horn/Strobe
	2824	✓	Horn Strobe
	5333		Multi-Tone Horn
	5336	✓	Multi-Tone Horn/Strobe
	5337	✓	Multi-Tone Horn/Strobe
	5338	✓	Multi-Tone Horn/Strobe
	5343	✓	Single Tone Horn/Strobe
	5346	✓	Electronic Horn with Strobe
	5347	✓	Electronic Horn with Strobe
	5348	✓	Single Tone Horn/Strobe
	5373	✓	8-Tone Horn/Strobe
	5376	✓	8-Tone Horn/Strobe
	5377	✓	8-Tone Horn/Strobe
5378	✓	8-Tone Horn/Strobe	
5383	✓	8-Tone Horn/Strobe with Sync Strobe	

Table A-1: Compatible Notification Appliances

Manufacturer	Model	Sync	Type
Faraday (Cont.)	5386	✓	8-Tone Horn/Strobe with Sync Strobe
	5387	✓	8-Tone Horn/Strobe with Sync Strobe
	5388	✓	8-Tone Horn/Strobe with Sync Strobe
	5405		Sync Control Unit
	5508	✓	Single Gang Sync Strobe
	5509	✓	Strobe
	5510	✓	Strobe
	5511	✓	Strobe
	5512	✓	Strobe
	5516	✓	Strobe
	5517	✓	Strobe
	5518	✓	Strobe
	5519	✓	Strobe
	5521	✓	4" Square Sync Strobe
	5522	✓	4" Square Sync Strobe
	6120		Horn
	6140		Horn
	6223		Horn
	6226	✓	Horn/Strobe
	6227	✓	Horn/Strobe
	6228	✓	Horn/Strobe
	6243		Electron-Mechanical Horn
	6244		Electron-Mechanical Horn
	6245		Electron-Mechanical Horn
	6246	✓	Electron-Mechanical Horn/Strobe
	6247	✓	Electron-Mechanical Horn/Strobe
	6248	✓	Electron-Mechanical Horn/Strobe
	6300		Mini-Horn
	6301		Mini-Horn
	6302		Mini-Horn
	6310	✓	Mini-Horn/Strobe
	6311	✓	Mini-Horn/Strobe
	6312	✓	Mini-Horn/Strobe
	6314 Series -M, -R, -T, -Y, -Z	✓	Strobe
	6320	✓	Sync Mini Horn/Strobe
	6321	✓	Sync Mini Horn/Strobe
	6322	✓	Mini Horn/Sync Strobe
	6380	✓	8-Tone Electronic Signal/Strobe

Table A-1: Compatible Notification Appliances

Manufacturer	Model	Sync	Type
FCI	130-3117C		Mini Horn
	130-3147C		Mini Horn
	BLV-6		Vibrating Bell
	BLV-10		Vibrating Bell
	BLVCH		Vibrating Chime
	H12/24-FC		Horn
	H12/24W-FC		Horn
	H12/24K-FC		Horn
	HC12/24-FC		Horn
	HC12/24W-FC		Horn
	HC12/24K-FC		Horn
	P2415-FC	✓	Horn/Strobe
	P2415W-FC	✓	Horn/Strobe
	P2415K-FC	✓	Horn/Strobe
	P241575-FC	✓	Horn/Strobe
	P241575W-FC	✓	Horn/Strobe
	P241575F-FC	✓	Horn/Strobe
	P241575K-FC	✓	Horn/Strobe
	P2430-FC	✓	Horn/Strobe
	P2430W-FC	✓	Horn/Strobe
	P2430K-FC	✓	Horn/Strobe
	P2475-FC	✓	Horn/Strobe
	P2475W-FC	✓	Horn/Strobe
	P2475K-FC	✓	Horn/Strobe
	P24110-FC	✓	Horn/Strobe
	P24110W-FC	✓	Horn/Strobe
	P24110K-FC	✓	Horn/Strobe
	S2415-FC	✓	Strobe
	S241575-FC	✓	Strobe
	S241575W-FC	✓	Strobe
	S241575K-FC	✓	Strobe
	S2430-FC	✓	Strobe
	S2430W-FC	✓	Strobe
	S2430K-FC	✓	Strobe
	S2475-FC	✓	Strobe
	S2475W-FC	✓	Strobe
	S2475K-FC	✓	Strobe
	S24110-FC	✓	Strobe
	S24110W-FC	✓	Strobe
	S24110K-FC	✓	Strobe
	MDL-FC		Sync. Module
	MDLW-FC		Sync. Module

Table A-1: Compatible Notification Appliances

Manufacturer	Model	Sync	Type
Federal Signal	450		Horn
	VALS		Horn/Strobe
Gentex	GX90-4		Horn
	GXS-4-15-1	✓	Strobe
	GXS-4-1575	✓	Strobe
	GX90S-4-15		Horn
	GX90S-4-1575		Horn
	HG124		Horn
	SHG24-1575	✓	Horn/Strobe
	SHG24-15	✓	Horn/Strobe
	GEC Series	✓	Horn/Strobes
	GES Series	✓	Strobes
	GEH		Horns
	GMH-24-X		Horn
	GMS-24-X	✓	Horn/Strobe
	G0T24		Horn
	G0S24-X		Horn
	ST/HS Commander Series	✓	Strobes & Horn/Strobes
WGMS-24-X		Horn/Strobe	
System Sensor	H12/24		Horn
	HC12/24		Horn
	MASS241		Horn/Strobe
	MASS24110ADA		Horn/Strobe
	MASS2415ADA		Horn/Strobe
	MASS2475ADA		Horn/Strobe
	P2415	✓	Horn/Strobe
	P241575	✓	Horn/Strobe
	P2430	✓	Horn/Strobe
	P2475	✓	Horn/Strobe
	P24110	✓	Horn/Strobe
	S2415	✓	Strobe
	S241575	✓	Strobe
	S2430	✓	Strobe
	S24110	✓	Strobe
	SS24110ADA	✓	Strobe
	SS2415ADA	✓	Strobe
	SS2475ADA	✓	Strobe
	PS2415ADA	✓	Mini-Horn/Strobe
	PS241575ADA	✓	Mini-Horn/Strobe
PS24110ADA	✓	Mini-Horn/Strobe	

Table A-1: Compatible Notification Appliances

Manufacturer	Model	Sync	Type
System Sensor (Cont.)	PS2475ADA	✓	Mini-Horn/Strobe
	MDL		Sync. Module
	MDLW		Sync. Module
Wheelock	46T-G4-24-R		Bell
	46T-G6-24-R		Bell
	46T-G10-24-R		Bell
	46T-G6-24-WS-24-HF-R		Strobe/Bell
	46T-G10-24-WS-24-HF-R		Strobe/Bell
	46T-G6-24-WH-24-HF-R		Strobe/Bell
	46T-G10-24-WH-24-HF-R		Strobe/Bell
	7001T-12\24-W-FR		Strobe Horn
	7002T-12\24-W-FR		Strobe Horn
	AES-DL1-R		Multitone Horn
	AES-EL1-R		Multitone Horn
	AES-DL1-WS-24-VF-R		Multitone Horn
	AES-EL1-WS-24-VF-R		Multitone Horn
	AES-DL1-WH-24-VF-R		Multitone Horn
	AES-EL1-WH-24-VF-R		Multitone Horn
	AES-DL1-WM-24-VF-R		Multitone Horn
	AES-EL1-WM-24-VF-R		Multitone Horn
	AH-24-R		Horn
	AH-24WP-R		Horn
	AMT-12\24-R		Strobe Horn
	AMT-24-LS-VFR		Strobe Horn
	AMT-24-LSM-VFR		Strobe Horn
	AMT-24-IS-VFR		Strobe Horn
	AS-24MCW-FR	✓	Strobe Horn
	AS-24MCW-FW	✓	Strobe Horn
	AS-2415W-FR	✓	Strobe Horn
	AS-2415C-FW	✓	Strobe Horn
	AS-241575W-FR	✓	Strobe Horn
	AS-2475C-FW	✓	Strobe Horn
	AS-24100C-FW	✓	Strobe Horn
	AS-2430W-FR	✓	Strobe Horn
	AS-2430C-FW	✓	Strobe Horn
	AS-2475W-FR	✓	Strobe Horn
AS-24110W-FR	✓	Strobe Horn	
ASWP-2475W-FR	✓	Strobe Horn	
SM-12\24-R		Strobe Horn Controller	
DSM-12\24-R		Strobe Horn Controller	
CF-BF1		Chime	

Table A-1: Compatible Notification Appliances

Manufacturer	Model	Sync	Type
Wheelock (Cont.)	CF-BF1-R		Chime
	CH-CF1		Chime
	CH-CF1-R		Chime
	CH-CF1-W		Chime
	CH-DF1		Chime
	CH-DF1-R		Chime
	CH-BF1-WS-24-HF-R		Strobe Chime
	CH-CF1-LS-24		Strobe Chime
	CH-CF1-MS-24		Strobe Chime
	CH-CF1-IS-24		Strobe Chime
	CH-CF1-LS-24-CFW		Strobe Chime
	CH-CF1-MS-24-CFW		Strobe Chime
	CH-CF1-IS-24-CFW		Strobe Chime
	CH-CF1-WS-24-CF-W		Strobe Chime
	CH-DF1-LS-24		Strobe Chime
	CH-DF1-MS-24		Strobe Chime
	CH-DF1-IS-24		Strobe Chime
	CH-DF1-LS-24-VFR		Strobe Chime
	CH-DF1-LSM-24-VFR		Strobe Chime
	CH-DF1-MS-24-VFR		Strobe Chime
	CH-DF1-IS-24-VFR		Strobe Chime
	CH-DF1-WM-24-VFR		Strobe Chime
	CH-DF1-WS-24-VF-R		Strobe Chime
	DSM-12/24		Sync Module
	EH-DL1-R		Electronic Horn
	EH-EL1-R Electronic Horn		Electronic Horn
	EHS-DL1-W-VF-R		Strobe Horn (single input)
	EHS-EL1-W-VF-R		Strobe Horn (single input)
	EH-DL1-WS-24-VF-R		Strobe Horn (dual input)
	EH-EL1-WS-24-VF-R		Strobe Horn (dual input)
	EH-DL1-WH-24-VF-R		Strobe Horn (dual input)
	EH-EL1-WH-24-VF-R		Strobe Horn (dual input)
	EH-DL1-WM-24-VF-R		Strobe Horn (dual input)
	EH-EL1-WM-24-VF-R		Strobe Horn (dual input)
HSW-24-HFR		Remote Strobe	
HS2W-24-HFR		Remote Strobe	
HSPW-24-HFR		Remote Strobe	
IS-24-VFR		Remote Strobe	

Table A-1: Compatible Notification Appliances

Manufacturer	Model	Sync	Type
Wheelock (Cont.)	IS1-24-VFR		Remote Strobe
	IS3-24-VFR		Remote Strobe
	ISP-24-HFR		Remote Strobe
	LS-24-VFR		Remote Strobe
	LS1-24-VFR		Remote Strobe
	LS3-24-VFR		Remote Strobe
	LSP-24-HFR		Remote Strobe
	LSM-24-VFR		Remote Strobe
	LS1M-24-VFR		Remote Strobe
	LS3M-24-VFR		Remote Strobe
	LSPM-24-VFR		Remote Strobe
	MS-24-VFR		Remote Strobe
	MS1-24-VFR		Remote Strobe
	MS3-24-VFR		Remote Strobe
	MSP-24-HFR		Remote Strobe
	MB-G6-24-R		Motor Bell
	MB-G10-24-R		Motor Bell
	MBS-G6-24-W-HF-R		Motor Bell with Strobe
	MBS-G10-24-W-HF-R		Motor Bell with Strobe
	MIZ-24-R		Mini-Horn
	MIZ-24-W		Mini-Horn
	MIZ-24-LS-VFR		Mini-Horn/Strobe
	MIZ-24-LSM-VFR		Mini-Horn/Strobe
	MIZ-24-MS-VFR		Mini-Horn/Strobe
	MIZ-24-HSW-HFR		Mini-Horn/Strobe
	MIZ-24-IS-VFR		Mini-Horn/Strobe
	MIZ-24-WS-VF-R		Mini-Horn/Strobe
	MIZ-24-WS-VF-W		Mini-Horn/Strobe
	MIZ-24-WH-VF-W		Mini-Horn/Strobe
	MIZ-24-WM-VF-W		Mini-Horn/Strobe
	MT-12/24-R		Strobe Horn
	MT-24-LS-VFR		Strobe Horn
	MT-24-LSM-VFR		Strobe Horn
	MT-24-MS-VFR		Strobe Horn
	MT-24-IS-VFR		Strobe Horn
	MT-24-SL-VFR		Strobe Horn
	MT-24-SLM-VFR		Synch. Multitone Strobe
	MT-24-WM		Strobe
	MT-24-WM-VFR		Horn

Table A-1: Compatible Notification Appliances

Manufacturer	Model	Sync	Type
Wheelock (Cont.)	NS-24MCM-FR	✓	Horn Strobes
	NS-24MCW-FW	✓	Horn Strobes
	NS-2415W-FR	✓	Horn Strobes
	NS-241575W-FR	✓	Horn Strobes
	NS-2430W-FR	✓	Horn Strobes
	NS-2475W-FR	✓	Horn Strobes
	NS-24110W-FR	✓	Horn Strobes
	NS4-24MCW-FR	✓	Horn Strobes
	NS4-24MCW-FW	✓	Horn Strobes
	NS4-241575W-FR	✓	Horn Strobes
	NH-12/24-R		Horn
	RS-2415-HFR		Strobe
	RSP-2415-VFR		Strobe
	RS-241575-VFR		Strobe
	RSP-241575-VFR		Strobe
	RS-2430-VFR		Strobe
	RS-2430-HFR		Strobe
	RS-2475-VFR		Strobe
	RSP-2475-HFR		Strobe
	RS-24110-HFR		Strobe
	RSP-24110-HFR		Strobe
	SL-24-VFR		Synchronized Remote Strobe
	SL1-24-VFR		Synchronized Remote Strobe
	SL3-24-VFR		Synchronized Remote Strobe
	SLP-24-VFR		Synchronized Remote Strobe
	SLM-24-VFR		Synchronized Remote Strobe
	SL1M-24-VFR		Synchronized Remote Strobe
	SL3M-24-VFR		Synchronized Remote Strobe
	SLPM-24-VFR		Synchronized Remote Strobe
	SHW-24-VFR		Synchronized Remote Strobe
	SH2W-24-VFR		Synchronized Remote Strobe
	SHPW-24-VFR		Synchronized Remote Strobe
SCM-24-R		Controller for Synchronized Strobes	

Table A-1: Compatible Notification Appliances

Manufacturer	Model	Sync	Type
Wheelock (Cont.)	SM-12/24-R		Sync Module
	SR-2415-VFR		Sync Strobe
	SRP-2415-HFR		Sync Strobe
	SR-241575-VFR		Sync Strobe
	SRP-241575-VFR		Sync Strobe
	SR-2475-VFR		Sync Strobe
	SR-2475-HFR		Sync Strobe
	SR-24110-HFR		Sync Strobe
	SRP-24110-HFR		Sync Strobe
	V700IT-12\24-W-FR		Strobe Horn
	WM3T-24-FR		Remote Strobe
	WM3T-24-VFR		Remote Strobe
	WSIT-24-FR		Strobe
	WS3T-24-FR		Strobe
	WST-24-FR		Strobe

Silent Knight Fire Product Warranty and Return Policy

General Terms and Conditions

- All new fire products manufactured by Silent Knight have a limited warranty period of 18 months from the date of manufacture against defects in materials and workmanship. See limited warranty statement for details.
- This limited warranty does not apply to those products that are damaged due to misuse, abuse, negligence, exposure to adverse environmental conditions, or have been modified in any manner whatsoever.

Repair and RA Procedure

- All products that are returned to Silent Knight for credit or repair require a RA (Return Authorization) number. Call Silent Knight Customer Service at 800-446-6444 or 763-493-6435 between 8:00 A.M. and 4:45 P.M. CST, Monday through Friday to obtain a return authorization number. Silent Knight Technical Support is available at 800-328-0103 between 8:00 A.M. and 6:00 P.M. CST, Monday through Friday.
- RA number must be prominently displayed on the outside of the shipping box. See return address example under Advanced Replacement Policy.
- Include a packing slip that has the RA number, a content list, and a detailed description of the problem should be included with each return.
- All products returned to Silent Knight must be sent freight pre-paid. After product is processed, Silent Knight will pay for shipping product back to customer via UPS ground.
- Return the Silent Knight product circuit board only. Products that are returned in cabinets will be charged an additional \$50 to cover the extra shipping and handling costs over board only returns. **Do not return batteries.** Silent Knight has the authority to determine if a product is repairable. Products that are deemed un-repairable will be returned to the customer.
- Product that is returned that has a board date code more than 18 months from date of manufacture will be repaired and the customer will be assessed the standard Silent Knight repair charge for that model.

Advanced Replacement Policy

- Silent Knight offers an option of advance replacement for fire product printed circuit boards that fail during the first 6 months of the warranty period.
- For advance replacement of a defective board contact your local Silent Knight Distributor or call Silent Knight at 800-446-6444 or 763-493-6435 to obtain a RA (Return Authorization) number and request advanced replacement.
- Customers without a Silent Knight account must use a MasterCard, Visa, or American Express credit card to get an advance replacement.

- A new or refurbished board will be shipped to the customer. The customer will initially be billed for the replacement board but a credit will be issued after the repairable board is received at Silent Knight. All returned products must comply with the guidelines described under “General Terms and Conditions”.
- The defective board must be returned within 30 days of shipment of replacement board for customer to receive credit. No credit will be issued if the returned board was damaged due to misuse or abuse.
- Repairs and returns should be sent to:

Silent Knight

Attn: Repair Department

7550 Meridian Circle Suite 100

Maple Grove, MN 55369-4927

RA Number: _____

Limited Warranty

Silent Knight warrants that the products of its manufacture shall be free from defects in materials or workmanship for 18 months from the manufacturing date code on the printed circuit board, if such goods have been properly installed, are subject to normal proper use, and have not been modified in any manner whatsoever. Upon return of the defective product, Silent Knight will at its sole discretion, either repair or replace, at no cost, such goods as may be of defective material or workmanship. Customers outside the United States are to return products to their distributor for repair.

Silent Knight SHALL NOT UNDER ANY CIRCUMSTANCES BE LIABLE FOR ANY INCIDENTAL OR CONSEQUENTIAL DAMAGES ARISING FROM LOSS OF PROPERTY OR OTHER DAMAGE OR LOSSES OWING TO THE FAILURE OF Silent Knight PRODUCTS BEYOND THE COST OF REPAIR OR REPLACEMENT OF ANY DEFECTIVE PRODUCTS.

Silent Knight MAKES NO WARRANTY OF FITNESS OR MERCHANTABILITY AND NO OTHER WARRANTY, ORAL OR WRITTEN, EXPRESS OR IMPLIED, BEYOND THE 18 MONTH WARRANTY EXPRESSLY SPECIFIED HEREIN.



7550 Meridian Circle
Maple Grove, MN 55369-4927
763-493-6455
1-800-328-0103
Fax: 763-493-6475

© 2003 Silent Knight
Part Number 151161G, 08/03