

ReadyGuard Plus Security Systems

Installation and Setup Guide

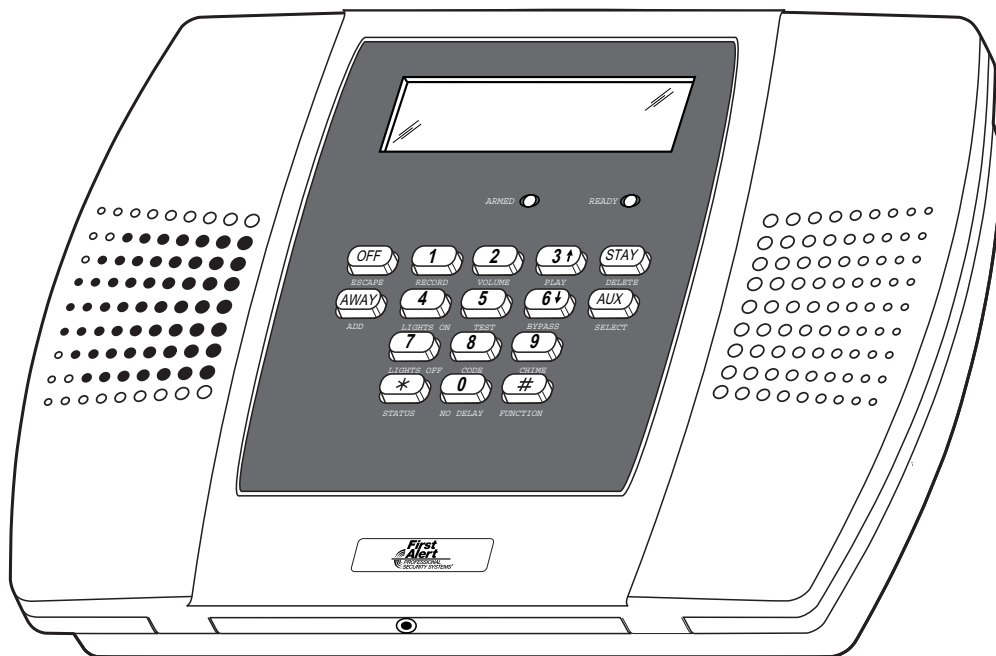

RECOMMENDATIONS FOR PROPER PROTECTION

The Following Recommendations for the Location of Fire and Burglary Detection Devices Help Provide Proper Coverage for the Protected Premises.

Recommendations for Smoke and Heat Detectors

With regard to the number and placement of smoke/heat detectors, we subscribe to the recommendations contained in the National Fire Protection Association's (NFPA) Standard #72 noted below.

- Early warning fire detection is best achieved by the installation of fire detection equipment in all rooms and areas of the household as follows: For minimum protection a smoke detector should be installed outside of each separate sleeping area, and on each additional floor of a multi-floor family living unit, including basements. The installation of smoke detectors in kitchens, attics (finished or unfinished), or in garages is not normally recommended.
- For additional protection the NFPA recommends that you install heat or smoke detectors in the living room, dining room, bedroom(s), kitchen, hallway(s), attic, furnace room, utility and storage rooms, basements and attached garages.

In addition, we recommend the following:

- Install a smoke detector inside every bedroom where a smoker sleeps.
- Install a smoke detector inside every bedroom where someone sleeps with the door partly or completely closed. Smoke could be blocked by the closed door. Also, an alarm in the hallway outside may not wake up the sleeper if the door is closed.
- Install a smoke detector inside bedrooms where electrical appliances (such as portable heaters, air conditioners or humidifiers) are used.
- Install a smoke detector at both ends of a hallway if the hallway is more than 40 feet (12 meters) long.
- Install smoke detectors in any room where an alarm control is located, or in any room where alarm control connections to an AC source or phone lines are made. If detectors are not so located, a fire within the room could prevent the control from reporting a fire or an intrusion.

THIS CONTROL COMPLIES WITH NFPA REQUIREMENTS FOR TEMPORAL PULSE SOUNDING OF FIRE NOTIFICATION APPLIANCES.

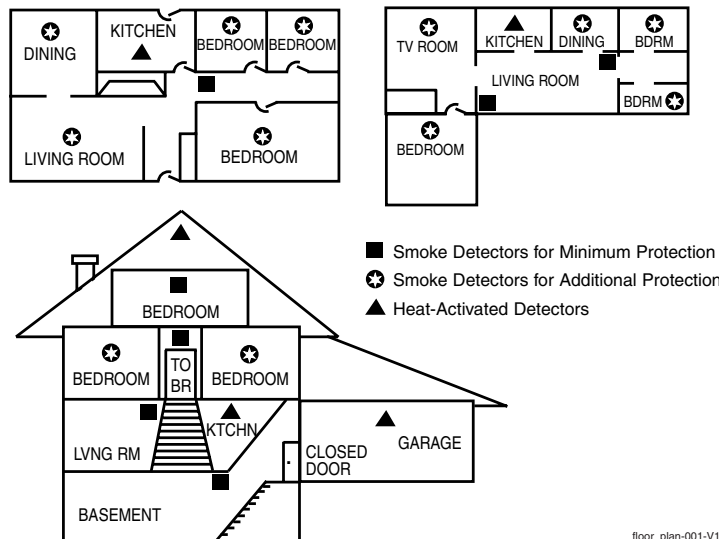

Recommendations For Proper Intrusion Protection

- For proper intrusion coverage, sensors should be located at every possible point of entry to a home or premises. This would include any skylights that may be present, and the upper windows in a multi-level building.
- In addition, we recommend that radio backup be used in a security system. This will ensure that alarm signals can be sent to the alarm monitoring station in the event that the telephone lines are out of order (alarm signals are normally sent over the phone lines, if connected to an alarm monitoring station).

Table of Contents

SYSTEM FEATURES	5
MOUNTING THE CONTROL.....	6
WIRING CONNECTIONS.....	7
CONNECTING/CONFIGURING COMMUNICATIONS DEVICES	9
AC POWER AND BACKUP BATTERY.....	11
INSTALLING WIRELESS ZONES.....	13
MECHANICS OF PROGRAMMING	16
ZONE RESPONSE TYPE DEFINITIONS	18
DATA FIELD DESCRIPTIONS	20
*56 ENHANCED ZONE PROGRAMMING MODE	35
*80 DEVICE PROGRAMMING MENU MODE	40
*81 ZONE LIST MENU MODE.....	44
*83 ENHANCED SEQUENTIAL MODE	46
*84 ASSIGN ZONE VOICE DESCRIPTORS	49
*85 RECORD CUSTOM VOICE DESCRIPTORS.....	50
REMOTE PROGRAMMING/CONTROL (DOWNLOADING)	51
SYSTEM OPERATION.....	53
TESTING THE SYSTEM	58
SYSTEM COMMUNICATION	59
TROUBLESHOOTING GUIDE	61
PROGRAMMING DEFAULT TABLES.....	63
REGULATORY AGENCY STATEMENTS	66
LIMITATIONS OF THIS SYSTEM STATEMENT.....	67
UL NOTICES.....	67
SPECIFICATIONS.....	68
CONTACTING TECHNICAL SUPPORT.....	68
WARRANTY INFORMATION	68
INDEX.....	69
SUMMARY OF CONNECTIONS DIAGRAM	Rear Cover

System Features

The ReadyGuard Plus control is a self-contained, rechargeable wireless control/communicator that features easy installation and usage. A built-in speaker provides voice annunciation of system status along with voice descriptors of each zone. An internal module (if provided) allows the ReadyGuard Plus to communicate with the Central Station via the Internet.

UL

ReadyGuard Plus is not intended for UL985 Household Fire applications unless a 24-hour backup battery (P/N LYNXRCHKIT-HC or LYNXRCHKIT-SHA) is installed.

Powerline Carrier Devices have not been evaluated by UL.

Features

System Features

- Real-time clock display and 2 line by 16 character alpha display
- Message center (for user recorded messages)
- Voice announcement of system and zone status
- Voice chime
- Alarm clock
- Reminder
- X10 scheduling
- Latch key reports
- Automatic stay arming
- Remote phone control
- Speaker phone operation
- "Follow me" reminder and system announcements
- 8 User Codes (Installer, Master, 5 Secondary, Duress)
- 3 Panic Functions

Zones and Devices

- 1 Hardwire zone
- Up to 24 Wireless zones (5800 Series transmitters)
- Up to 16 Wireless button zones
- Up to 8 Powerline carrier devices
- Supports wireless keypads

Communication

- Ademco Low Speed
- Sescoa/Radionics
- Ademco Express
- Ademco Contact ID
- Internet central station communication
- GSM cellular central station communication
- Two-way voice communication Supports AlarmNet remote services

Alarm Output

- Built-in sounder
- Bell output (120mA max.)
- Steady output for burglary/panic
- Temporal pulse output for fire and carbon monoxide alarms
- Long range radio/audio alarm verification

Programming

- Options stored in EEROM
- Can be downloaded or controlled via IBM-compatible computer using Compass downloader software and specified HAYES-compatible modem or via capable GSM or IP communications module
- Voice prompt programming mode

Other Features

- Exit error feature (detects difference between an actual alarm and exit alarm caused by leaving a door open after the exit delay expires)
- Event log stores up to 84 events
- Macro/ 1-button paging
- RF jam detection
- Compatible with encrypted (high-security) devices

System Power

- Primary Power: K10145WH or K10145X10 plug-in transformer, 110VAC to 9VAC, 25VA output (K10145CN in Canada)
- Backup battery: Rechargeable nickel-metal hydride battery pack rated at 7.7Vdc.

Mounting the Control

Wall Mounting

1. Release the front assembly from the back case by depressing the two locking tabs at the top of the unit with the blade of a medium size screwdriver.
2. Separate the front and back case assemblies by rotating the front case so that it is perpendicular to the back case and unsnapping (releasing) the two hooks from the back case.
3. Feed the field wiring through the appropriate openings in the back case. Use tie-wraps to secure the wiring to the built-in wire loops as needed.
4. Mount the back case to a sturdy wall.
5. Attach the front and back cases by connecting the hooks on the front case to the attachments on the rear case. Once attached, the hooks will support the front case and allow you to make the wiring connections.
6. After all wiring connections have been made, snap the front case and back case closed and ensure that the control is secured by the locking tabs.

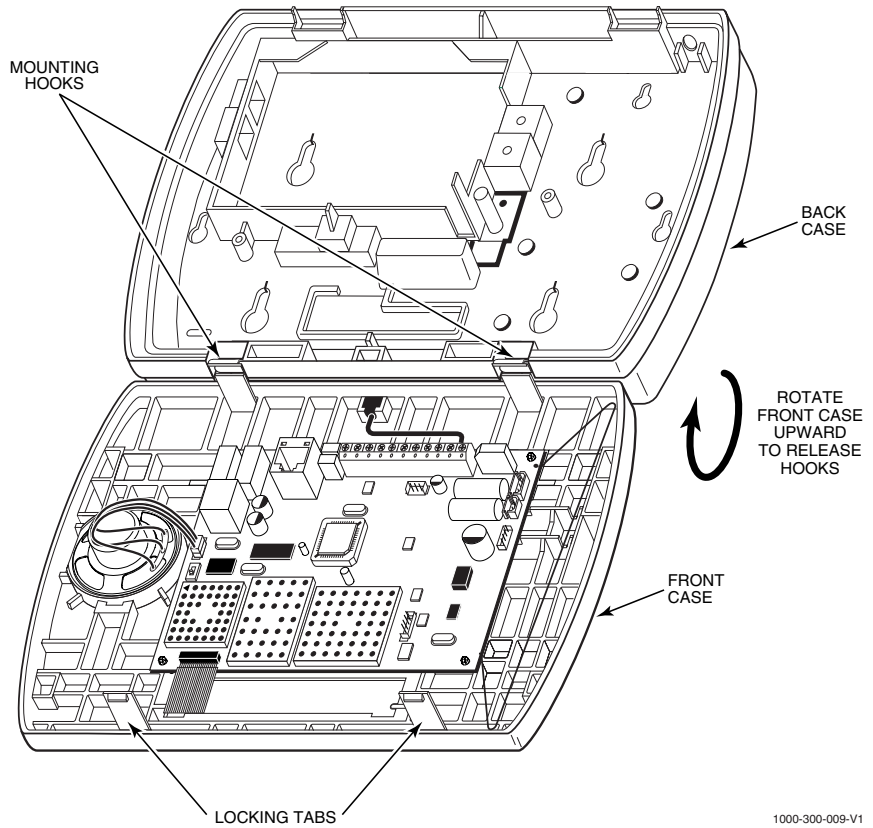

1000-300-009-V1

Desktop Mounting

For desktop mounting, the optional mounting base (model LYNXPLUS-DM, purchased separately) must be used.

1. Slide the control panel onto the mounting base locking tabs.
2. Bring all wiring through the bottom of the mounting base, using one of the wire entry locations, before making connections to the control panel.
3. Use tie-wraps to secure the wiring to the built-in wire loops as needed.
4. Use the supplied screws to secure the control panel to the mounting base.

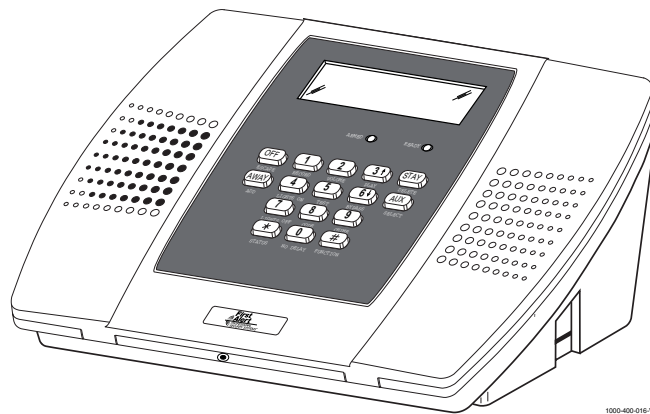

1000-400-016-V0

Wiring Connections

Wiring Overview

The following summarizes the connections required. Refer to the Wiring Connections paragraph and the Summary of Connections diagram on the inside back cover when making connections. Ensure that the battery cable is routed as shown in the figure below.

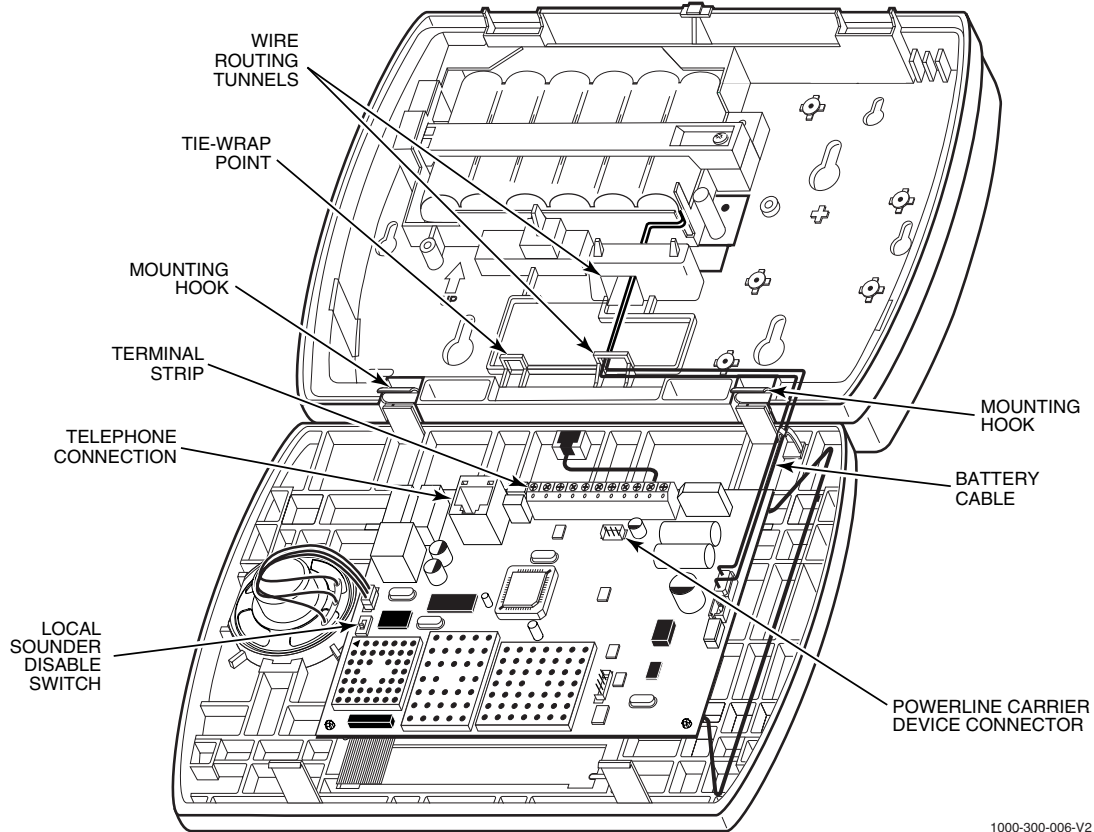

1000-300-006-V2

Wiring Connections

1. **Make Earth Ground Connection** - The designated earth ground terminal (1) must be terminated in a good earth ground for the lightning transient protective devices in this product to be effective. The following are examples of good earth grounds available at most installations:

Metal Cold Water Pipe - Secure a non-corrosive metal strap (copper is recommended) to the pipe that is electrically connected and secured to which the ground lead is electrically connected and secured.

AC Power Outlet Ground - Available from 3-prong, 120VAC power outlets only. To test the integrity of the ground terminal, use a three-wire circuit tester with neon lamp indicators, such as the UL Listed Ideal Model 61-035, or equivalent, available at most electrical supply stores.

- a. Connect terminal 1 to a good earth ground.

2. **Make Phone Line Connections** - For local or full line seizure follow the appropriate steps below.

Local Seizure

- a. Connect the incoming phone line to either the 8-position jack or terminals 2 (TIP) and 3 (RING) on the ReadyGuard Plus.
- b. Connect the handset phone lines to terminals 4 (TIP) and 5 (RING).

Full Line Seizure: The control must be placed in **series** with the incoming phone line. Plugging the Direct Connect Cord directly into the RJ31X jack, allows the control to seize the phone line when an alarm occurs and normal phone line usage by the premises phones if the plug needs to be removed.

- a. Cut the incoming RING and TIP phone lines (typically red and green, respectively) and connect them to RJ31X terminals 4 (red) and 5 (green).
- b. Connect the premises end of the cut RING and TIP wires to RJ31X terminals 1 (grey) and 8 (brown) respectively.

Wiring Connections

- c. Wire the flying leads of a Direct Connect Cord to the control's phone terminals as shown in the diagram or plug into the 8-position jack.
- d. Plug the Direct Connect Cord into the RJ31X jack.

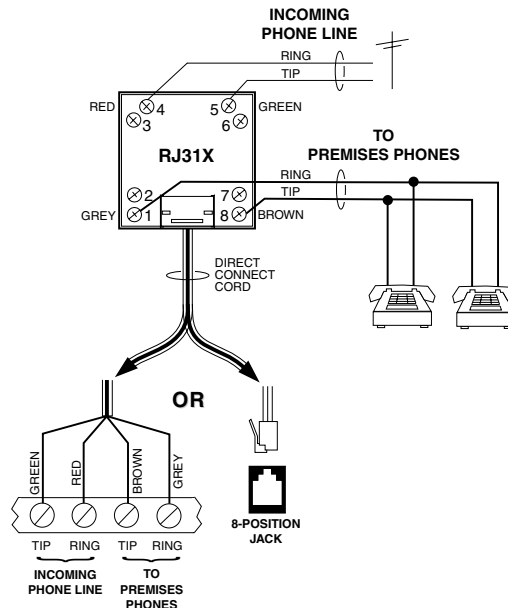

Full Line Seizure Connections

01000-008-V0

UL

The local sounder disable switch must be set to "ON" position.

External sounders and powerline carrier devices have not been evaluated by UL



LOCAL SOUNDER DISABLE: The Master Keypad's built-in piezo sounder can be disabled by setting the sounder disable switch to OFF. If disabled, however, no sounding will occur upon AC loss, since the external sounder does not operate when AC power is lost.

HARDWIRED ZONE: If the EOLR is not at the end of the loop, the zone will not be properly supervised, and the system may not respond to an open circuit on the zone.

3. Hardwired Zone Connections

Zone 1 is an EOLR supervised zone that supports both open circuit and closed circuit devices and has a response time of 350msec. Maximum zone resistance: 300 ohms, plus EOLR

Note: The hardwire zone cannot be used as a fire or CO zone.

- a. Connect sensors/contacts to the hardwired zone terminals 6 (-) and 7 (+). Refer to the Summary of Connections diagram.
 - b. Connect closed circuit devices in series in the high (+) side of the loop. The EOL resistor must be connected in series with the devices, following the last device.
 - c. Connect open circuit devices in parallel across the loop. The 2000-ohm EOLR must be connected across the loop at the last device.
4. **Make External Sounder Connections** - The control panel a 6-14VDC bell (120mA max.; e.g. ADEMCO WAVE2EX).
 - a. Connect a bell to terminals 8 (-) and 9 (+).
 5. **Disable Local Sounder Option** - If required, the Master Keypad's built-in piezo sounder can be disabled.
 - a. Set the Local Sounder Disable Switch to OFF.
 6. **Make Powerline Carrier Device Connections** - The control panel supports up to 8 Powerline Carrier Devices. If using these devices, they must be connected to the control via a K10145X10 transformer.
 - a. Connect the com/data/sync/ lines from the K10145X10 transformer to the Powerline Carrier Device Connector using the provided cable.



Refer to the *80 Device Programming Menu Mode section to program the Powerline Carrier Devices.

Connecting/Configuring Communication Modules

General

This ReadyGuard Plus control supports central station reporting via the internet using wireless (GSM) and hardwire (IP) communications modules. It also supports upload/download programming capability via the Internet or a Private local area network (Intranet). This allows site maintenance independent of central station monitoring, and modification to sites globally via the Internet or through a private LAN. Refer to the instructions provided with the LRR/IP Communications Device being installed for additional information regarding its installation, programming, and registration. The control is compatible with the following AlarmNet Communications Modules:

- 7847i-L Internet Communications Module
- GSMVLP GSM Communications Module with 2-Way Voice

Connecting Long Range Radio and Internet Communication Devices

Connect and configure the communications device (refer to the Installation Instructions for device that you are installing for additional information).

LRR/IP Communications Device 24-Hour Standby Power

If you are installing the AlarmNet 7847i-L, and require 24-hour standby, you must install the Super High Capacity battery P/N WALYNX-RCHB-SHA in the control.

Configuring Long Range Radio and Internet Communication Devices

1. Enable the communications device in programming field *55 and configure alarm reporting and module supervision in programming field *77.
2. Program the device as required using the 7720P programmer (refer to the Installation Instruction for the device that you are installing). Note that the device address must be set to 3.



The device must be registered before downloading or alarm reporting can take place.

LRR Communications Device Diagnostic Mode

This mode provides a method to verify the LRR signal strength.

1. Enter the Installer Code (4112) + 899. The system will initially display “Entering programming mode”.
2. The LRR Communications Module’s Signal Level (Primary Site Received Signal Strength Indication [PriRSSI]) will be displayed in dBm. The system will also display GPRS connection and registration indications (refer to the example that follows).
3. If “FAIL” or “POOR” signal levels are displayed during the test, the control should be relocated to find a location that provides better signal strength.



If a ‘searching for coverage’ message is displayed or the radio is not connected and no signal indication is displayed, the installer should check radio programming, panel programming, etc., before entering this mode again.

Signal strength may vary

4. The ReadyGuard Plus will automatically exit this mode after approximately 1-minute or if any key is pressed. The system will display “Exiting programming mode” when the test is complete.

Connecting/Configuring Communication Modules

Example:

SIGNAL	GPRS	REG
-86	GOOD	Y H

Diagnostic Mode Definitions

SIGNAL = Communications Module's Signal Level (RSSI) will be displayed in dBm, where:

-01 to -93 GOOD = Good signal level

-94 to -95 POOR = Poor signal level, move unit for better signal level

-96 (and lower) FAIL = Fail signal level, do not install, move unit for better signal level. If "FAIL" condition persists, do not install

0 or "Searching for Coverage" = Waiting for signal. Try again in a few minutes. If no signal persists, move unit for better signal level, check all connections and SIM activation.

GPRS = GPRS Service availability where:

Y = GPRS is available

N = GPRS is Not available

REG = Registration status from radio module where

N = Not Registered (contact AlarmNet)

H = Registered Home (functioning normally)

S = Searching (wait or move unit to another location)*

D = Registration Denied (contact AlarmNet)

R = Registered Roaming (no problem)

? = Unknown Registration State (wait or move unit to another location)*

* If the unit is in an area of known cellular coverage for 3 – 5 min and these conditions do not clear contact AlarmNet for assistance.

AC Power and Backup Battery

The system is powered by a 9VAC, 25VA Plug-in Transformer, K10145WH or K10145X10 (K10145CN in Canada). Refer to the wiring table below for wire gauge and length.

Distance between Transformer and Control	Wire Gauge
Up to 75 feet	#20
75 to 150 feet	#18
150 to 300 feet	#16



Use only the provided ADEMCO K10145WH/K10145X10 or K10145CN Transformer. Wiring to the AC Transformer must not exceed 300 feet using 16-gauge wire. The voltage reading between terminals 10 and 11 of the control must not fall below 9.00VAC.

Do not plug the transformer into the AC outlet until after all wiring connections have been made. Ensure the cover is snapped closed prior to applying AC power

Backup battery

In the event of an AC power loss, the system is supported by a long life backup battery that is supervised for connection and for low voltage conditions. If the battery is missing, or a low battery condition is detected, a “low battery” message is displayed and a report is sent to the central station. In addition, the system will beep once every 45 seconds to audibly indicate a low battery condition (press any key to stop the beeping).

AC Power and Rechargeable Backup Battery

Connecting AC Power and backup battery

1. Connect wires from the K10145WH or K10145X10 (K10145CN in Canada) AC Transformer to terminals 10 and 11 as shown on the summary of connections diagram.
2. Remove battery retainer.
3. Insert battery pack into back plate.
4. Install battery retainer.
5. Secure battery retainer with the provided screw.
6. Connect battery pack connector to the receptacle on the PC board.
7. After all wiring connections have been made, snap the case closed and plug the transformer into a 24-hour, 110VAC unswitched outlet.

Note: Rechargeable batteries may take up to 48-hours to fully charge. The “LOW BAT” message should clear within four hours or by entering Test Mode.

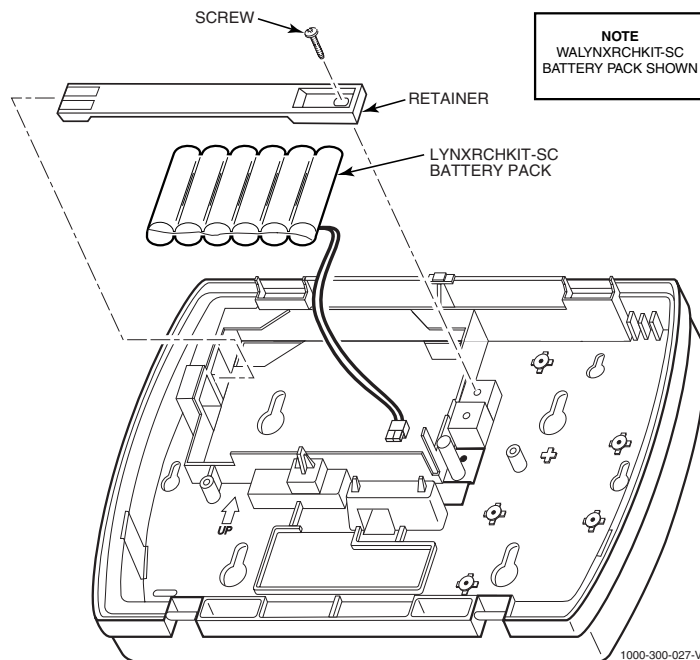

AC Power and Backup Battery

AC Power and Rechargeable Backup Battery

The ReadyGuard Plus is equipped with an integral, replaceable, rechargeable battery pack rated at 7.7Vdc. Select the appropriate battery pack, based on the installation's requirement, and install the battery pack.

Battery Part Number	Battery StandbyTime	Low Battery Notification
LYNXRCHKIT-SC	4-hours (minimum)	Approximately 1-hour before battery depletion
LYNXRCHKIT-HC	24-hours (minimum)	At least 1-hour before battery depletion
LYNXRCHKIT-SHA	24-hours (minimum)	At least 1-hour before battery depletion

Replacing the Rechargeable Battery

1. When battery replacement is required, unplug the transformer from the wall outlet, and open the control panel cover.
2. Remove the screw that secures the battery retainer.
3. Remove the battery retainer and disconnect the battery pack connector from the receptacle on the PC board.
4. Remove the battery pack from the back plate.
5. Install a replacement battery pack (P/N LYNXRCHKIT-SC, LYNXRCHKIT-HC or LYNXRCHKIT-SHA) into the back plate.
6. Install the battery retainer.
7. Secure battery retainer with the provided screw as shown below.
8. Connect the battery connector to the appropriate receptacle on the PC board.
9. After the wiring connection has been made, snap the front assembly and the back plate closed.
10. Plug the transformer into a 24-hour, 110VAC unswitched outlet.
11. Rechargeable batteries may take up to 48-hours to fully charge. The "LOW BAT" message should clear within four hours or by entering Test Mode.

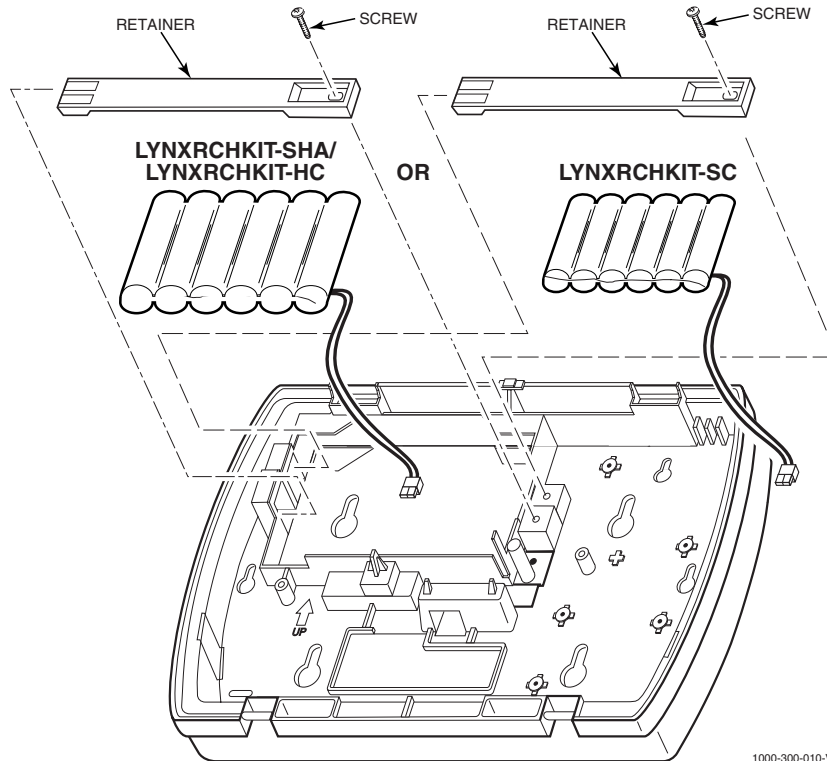

1000-300-010-V0



Ensure the control panel assembly is snapped closed prior to applying AC power.

Installing Wireless Zones

General Information

Zones: The control supports up to 24 wireless zones using 5800 Series transmitters, and up to 16 wireless buttons.

Range: The built-in RF receiver can detect signals from wireless transmitters within a nominal range of 200 feet.

Transmitters: 5800 Series transmitters have built-in serial numbers that must be entered into the system using the *56 or *83 interactive mode, or input to the control via the downloader. 5800 Series transmitters (except the 5800RL, which is described separately) do not have DIP switches. Each transmitter's zone number is programmed into the system in *56 mode. Some transmitters, such as the 5816 and 5817, can support more than one "zone" (referred to as loops or inputs). On the 5816, for example, the wire connection terminal block is loop 1; the reed contact is loop 2. Each loop must be assigned a different zone number.

UL

The 5816 and 5817 Transmitters do not have EOL supervision of their loop wiring and the loop wiring must not exceed 3 feet.

The 5800RL, 5802MN, 5802MN2, 5804, 5804BD, 5804BDV, 5804E, 5814, 5816TEMP, 5819, 5819S(WHS & BRS), 5828/5828V and 5850(GBD) transmitters have not been evaluated by UL.

For button transmitters (RF "keys") such as the 5804 and 5801, you must assign a unique zone number to each individual button used on the transmitter. Each button on the transmitter also has a pre-designated loop or input number, which is automatically displayed.

House Identification

If you are using a 5804BD/5804BDV Wireless Keypad with the system, you must program a House ID Code (01–31) in field *24 to establish proper communication, and the keypad must be set to the same ID. House ID 00 disables all wireless keypads. An RF House ID is not necessary for other 5800 Series transmitters; the entry should be left at "00" (default) in those cases.

Transmitter Supervision

Except for some transmitters/keypads that may be carried off-premises (5804, 5804BD, 5804BDV, and 5804E), each transmitter is supervised by a check-in signal that is sent to the receiver at 70–90 minute intervals. If at least one check-in is not received from each supervised transmitter within a 12-hour period, the "missing" transmitter number(s) and "FAULT" will be displayed. Additionally, the panel will beep once every 45 seconds until acknowledged. The supervision for a particular transmitter in the system that may also be carried off the premises (5801, 5802MN) may be turned off by entering it as a "UR" (unsupervised RF) type, as described in the *56 *Enhanced Zone Programming Mode* section. 5800 Series transmitters have built-in tamper protection and dependant on system status, will annunciate as a fault or alarm condition if covers are removed.

Transmitter Input Types

Each of the following transmitters has one or more unique factory-assigned input (loop) ID codes. Each of the inputs requires a programming zone (e.g., a 5804's four inputs require four button zones). Transmitters can be entered as one of the following types (see transmitter's instructions for appropriate input type):

Type	Description
"RF" (Supervised RF)	Sends periodic check-in signals, as well as fault, restore, and low battery signals. The transmitter must remain within the receiver's range.
"UR" (Unsupervised RF)	Sends all the signals that the "RF" type does, but the control does not supervise the check-in signals. The transmitter may therefore be carried off-premises.
"BR" (Unsupervised Button RF)	These only send fault signals. They do not send low battery signals until they are activated. The transmitter may be carried off-premises.

Transmitter Battery Life

- Batteries in the wireless transmitters may last from 4–7 years, depending on the environment, usage, and the specific wireless device being used. Factors such as humidity, high or low temperatures, as well as large swings in temperature may all reduce the actual battery life in a given installation. The wireless system can identify a true low battery situation, thus allowing the dealer or user of the system time to arrange a change of battery and maintain protection for that point within the system.

Installing Wireless Zones

- Button-type transmitters should be periodically tested for battery life. The 5801, 5802MN, 5802MN2, 5804, 5804BD, 5804BDV, and 5804E button transmitters have replaceable batteries.

Using the Transmitter Sniffer Mode

Use this mode after all transmitters have been entered to check that all transmitters have been properly programmed.

1. Enter **Installer code (4112) + [#] + 3**.

Note: If the communicator is in the process of sending a report to the central station, the system will not go into the Sniffer mode. If so, wait a few minutes and try again.

2. The keypad will display all zone numbers, which have a non-zero Zone Type (even if serial numbers were not learned yet). Fault each transmitter in turn, causing each one to send a signal. As the system receives a signal from each of the transmitters, the zone number of that transmitter will **disappear** from the display. The transmitters may be checked upon installation, or in an installed system.
3. When all transmitters have been checked, exit Sniffer mode. Enter **Installer Code (4112) + OFF**.

- Notes:**
- (1) Sniffer mode does not automatically expire. You must manually exit (Installer Code + OFF) Sniffer mode to return to normal operation.
 - (2) All BR-type units must physically be activated to clear the display, since they do not automatically send check-in signals.
 - (3) When one button of a transmitter (RF, UR, or BR) is activated, all zones assigned to other buttons on that transmitter are cleared. This also applies to 5816 and 5817 transmitters that have multiple loops (zones).
 - (4) Any transmitter that is not "entered" will not turn off its zone number.

Go/No Go Test Mode



5804E encrypted (High-Security) devices must be activated while the system is in Go/No Go Test Mode. Refer to the transmitter's installation instructions for complete details. The system will confirm enrollment of the encrypted device by beeping two times

The Go/No Go tests will verify adequate RF signal strength from the proposed transmitter location, and allow you to reorient or relocate transmitters if necessary, before mounting the transmitters permanently. This mode is similar to the transmitter Test mode, except that the wireless receiver gain is reduced. This will enable you to make sure that the RF signal from each transmitter is received with sufficient signal amplitude when the system is in the normal operating mode.

1. Enter **Installer Code (4112) + [#] + 8**.
2. Once you have placed transmitters in their desired locations and the approximate length of wire to be run to sensors is connected to the transmitter's screw terminals (if used), fault each transmitter.



Conducting this test with your hand wrapped around the transmitter will cause inaccurate results.

On button type transmitters that have been programmed to set ARM AWAY, ARM STAY, or DISARM, pressing a button will take the system out of the Go/No Go Test mode causing the programmed action to occur.

- a. The keypad will beep three times indicating signal reception and will display the appropriate zone number.
 - b. If the keypad does not beep, reorient or move the transmitter to another location. Usually a few inches in either direction is all that is required.
3. If each transmitter produces the proper keypad response when it is faulted, you can then permanently mount each of the transmitters according to the instructions provided with them.
 4. Exit the Go/No Go Test mode by entering: **Installer Code (4112) + OFF**.

Installing Wireless Zones

5800 Series Transmitter Loop Numbers (Refer to this information when programming transmitters)
 The following illustration shows the compatible transmitters, their associated input types and loop designations.

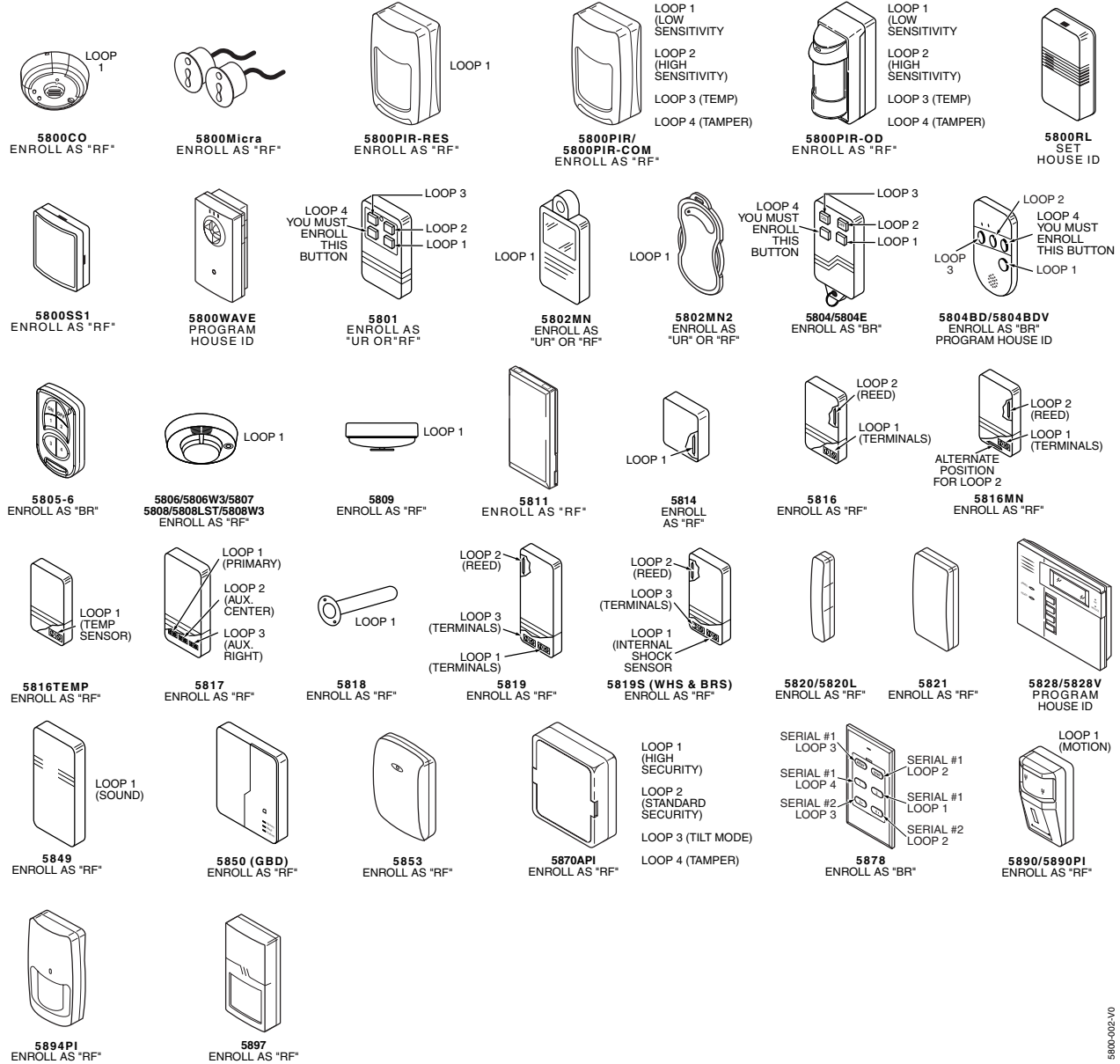

- Notes:**
- (1) Loop 4 must be enrolled on the 5801, 5804, 5804BD, 5804BDV and 5804E transmitters, whether or not the loop is used.
 - (2) 5804E encrypted (High-Security) devices must be activated while the system is in Go/No Go Test Mode. Refer to the transmitter's installation instructions for complete details. The system will confirm enrollment of the encrypted device by beeping two times.



The 5800PIR, 5800PIR-RES, 5800PIR-COM, 5800PIR-OD, 5800RL, 5802MN, 5802MN2, 5804, 5804BD, 5804BDV, 5804E, 5811, 5814, 5816TEMP, 5819, 5819S(WHS & BRS), 5828/5828V, 5850(GBD) and 5870API wireless transmitters have not been evaluated by UL.

5800-002-V0

Mechanics of Programming

General Programming Information

Programming options are stored in non-removable, electrically erasable, nonvolatile EEROM memory. The system can be programmed at any time, even at the installer's premises prior to the actual installation. Simply apply power temporarily to the Control and then program the unit as desired. There are four programming modes:

- **Data field programming** (used for setting various system options).
- **Interactive menu mode programming** (used for programming zone information, programming Powerline Carrier Devices, and for entering transmitter serial numbers).
- **Voice Prompt programming** (used for setting various system options).

The system can also be programmed remotely, using an IBM PC compatible Personal Computer, and Compass Downloader and modem or via capable GSM or IP communications modules. See the *Remote Programming / Control (Downloading)* section.

Note: You may find it convenient to adjust the volume setting before entering the Program Mode. This will allow you to clearly hear the feedback announcements or system beeps in the Programming Mode, of the system's built-in speaker. To adjust the volume, press FUNCTION + VOLUME+ [3] or [6]. Upon exiting the Program Mode, the system will reset the volume to the default value (mid level).

Entering Program Mode

Use one of the following methods to enter Programming Mode:

1. Press both the [*] and [#] keys at the same time, **within 50 seconds** after power is applied to the Control or from exiting Programming mode, **OR**
2. After power-up, enter the **Installer Code (4112) + 800** to enter **Expert Programming** mode **OR** enter **Installer Code (4112) + 888** to enter **Voice Prompt Programming** mode. This method is disabled if Program mode is exited using *98.



If a different Installer Code has been programmed, use that code to enter the Programming mode.

3. Upon entering programming mode, the control will initially display "Entering Programming Mode".
4. Once you have entered the Program mode, data field "20 INSTALLER CODE" (the first data field in the system) will be displayed and both keypad LEDs will flash. If you have entered the Voice Prompt Programming mode. "Pro" will be displayed and the system will announce "Programming, use arrows to scroll choices. Press select to accept, press escape to quit".

Programming a Data Field

1. Press [*] + Field No. (for example, *21), followed by the required entry.
2. When you have completely programmed a data field, the keypad will "beep" three times and then automatically display the next data field in sequence. To go to a different field, press [*] plus the desired field number.
3. If the number of digits that will be entered in a data field is less than the maximum number of digits available (e.g. phone number field), enter the desired data, then press [*] to advance to the next data field.
4. If a nonexistent field has been entered, the keypad will display "EE Invalid Entry". Simply re-enter [*] plus a valid field number.

Viewing a data field (without making changes):

Enter [#] + Field No. The system will beep three times and data programmed for that field will be displayed to the right of the field number. The system will scroll through the data for longer numbers and a beep will sound after each number is displayed or three times after the final digit is displayed.

Deleting an entry in a field

Enter [*] + Field No. + [*]. (Applies only to fields *40–*44, *88 and *94).

Mechanics of Programming

Interactive Menu Mode Programming (*56, *80, *81, *83, *84, *85)

Press [*] + interactive mode No. (i.e., *56). The keypad will display the first of a series of prompts. A detailed procedure (with displays of prompts) is provided in later sections of this manual.

*56 Enhanced Zone Programming Mode

Interactive menu mode used for programming zone attributes and report codes. Refer to the *56 *Enhanced Zone Programming Mode* section for procedure.

*80 Device Programming Menu Mode

Interactive menu mode for programming Powerline Carrier Devices. Refer to the *80 *Device Programming Menu Mode* section for detailed procedure.

*81 Zone Lists Menu Mode

Interactive menu mode for programming zone lists for Powerline Carrier Devices. Refer to the *81 *Zone List Menu Mode* section for detailed procedure.

*83 Enhanced Sequential Mode

Interactive menu mode used to enter RF transmitter serial numbers. Refer to the *83 *Enhanced Sequential Mode* section for detailed procedure.

*84 Assign Zone Voice Descriptors

Interactive menu mode used to assign descriptors to each zone. These descriptors will be announced whenever the system announces an event involving a zone.

*85 Record Custom Voice Descriptors

Interactive menu mode used to record custom descriptors for use with each zone.

*96 Initialize Download ID and Subscriber Account Number for Downloading

Entering *96 resets all subscriber account numbers and CSID in preparation for an initial download.

Loading Factory Defaults



If a default table is loaded, any data that has already been programmed into the system will be changed according to the default table selected!

- *97 To load the factory defaults, enter *97, then press number 1, 2, 3, or 4 to select from default tables 1-4, or press "0" if you are not selecting a default table. Refer to the Programming Default Tables section of this manual to view the tables.

Exiting Program Mode



Do not exit Program Mode via *98 if you intend to enter LRR Communication Device Diagnostic Mode.

- *98 Exits program mode and inhibits re-entry into the Expert or Voice Prompt Programming modes using the Installer Code.
- *99 Exits program mode but allows re-entry into the Expert Program mode using **Installer Code (4112) + 800** or into the **Voice Prompt Programming** mode using **Installer Code (4112) + 888**.

Note: After exiting program mode (or upon power-up), the system takes up to a minute to reset. To bypass the reset delay, press [#] + [0].

Zone Response Type Definitions

General Information

During programming, you must assign a zone type to each zone, which defines the way in which the system responds to faults in that zone. Zone types are defined below.

Type 00 Zone type 00 is used to program a zone that is not used.

Zone Not Used

Type 01 Zone type 01 is usually assigned to sensors or contacts on primary entry and exit doors.

Entry/Exit

Burglary #1

Zone Characteristics:

- Entry delay #1 is programmable (field *35).
- Exit delay is independently programmable (field *34).
- Exit and entry delays when armed in AWAY or STAY mode.
- No entry delay when armed in STAY NO DELAY or AWAY NO DELAY mode.
- Exit delay regardless of the arming mode selected.

Type 02 Zone type 02 is usually assigned to sensors or contacts on secondary entry and exit doors that might be further from the keypad (typically used for a garage, loading dock, or basement door).

Entry/Exit

Burglary #2

Zone Characteristics:

- Entry delay #2 is programmable from (field *36).
- Exit delay is independently programmable from (field *34).
- Secondary entry delay, if armed in the AWAY or STAY mode.
- No entry delay when armed in the STAY NO DELAY or AWAY NO DELAY mode.
- Exit delay begins regardless of the arming mode selected.

Type 03 Zone type 03 is usually assigned to all sensors or contacts on exterior doors and windows.

Perimeter

Burglary

Zone Characteristics:

- Instant alarm, when armed in AWAY, STAY, STAY NO DELAY, or AWAY NO DELAY mode.

Type 04

Interior,

Follower

Zone type 04 is usually assigned to a zone covering an entry area (i.e.: foyer, lobby, or hallway) that one must pass upon entry (after faulting the entry/exit zone) to reach the keypad. It provides an instant alarm if the entry/exit zone is not violated first, and protects an area in the event an intruder has hidden on the premises before the system is armed, or gains access to the premises through an unprotected area.

Zone Characteristics:

- Delayed alarm (using the programmed entry/exit time) if entry/exit (types 01 or 02) or interior-with-delay (type 10) zone is faulted first.
- Instant alarm in all other situations.
- Active when armed in AWAY or AWAY NO DELAY mode.
- Bypassed automatically when armed in STAY or STAY NO DELAY mode.

Type 05

Trouble by Day/

Alarm by Night

Zone type 05 is usually assigned to a zone that contains foil-protected doors or windows or covers a sensitive area (i.e.: stock room, drug supply room, etc.) It can also be used on a sensor or contact in an area where immediate notification of an entry is desired.

Zone Characteristics:

- Instant alarm, when armed in AWAY, STAY, STAY NO DELAY, or AWAY NO DELAY (night) mode.
- Provides a latched trouble sounding from the keypad and, if desired, a central station report during the disarmed state (day).

Type 06

24-hour

Silent Alarm

Zone type 06 is usually assigned to a zone containing an Emergency button (silent emergency).

Zone Characteristics:

- Sends a report to the central station but provides no keypad display or sounding.

Type 07

24-hour

Audible Alarm

Zone type 07 is usually assigned to a zone containing an Emergency button (audible emergency).

Zone Characteristics:

- Sends a report to the central station, and provides alarm sounds externally and at the keypad.

Type 08

24-hour

Auxiliary Alarm

Zone type 08 is usually assigned to a zone containing a button for use in personal emergencies or to a zone containing monitoring devices (i.e.: water or temperature sensors, etc.).

Zone Characteristics:

- Sends a report to the central station and provides an alarm sound at the keypad. (No bell output is provided and there is no keypad timeout.)

Zone Response Type Definitions

Type 09 Supervised Fire	<p>Zone type 09 can be assigned to any wireless zone used as a fire zone. This zone type is always active and cannot be bypassed.</p> <p>Zone Characteristics:</p> <ul style="list-style-type: none">• Bell output will pulse when this zone type is alarmed.
Type 10 Interior with Delay	<p>Zone type 10 is bypassed when the panel is armed in the STAY or STAY NO DELAY mode.</p> <p>Zone Characteristics:</p> <ul style="list-style-type: none">• Entry delay #1 (with programmed entry time) when armed in the AWAY mode.• Entry delay begins whenever sensors in this zone are violated, regardless of whether an entry/exit delay zone was tripped first.• No entry delay when armed in the AWAY NO DELAY mode.• Exit delay regardless of the arming mode selected.
Type 14 24-hour Carbon Monoxide Monitor	<p>Zone type 14 can be assigned to any wireless zone with a carbon monoxide detector. This zone type is always active and cannot be bypassed.</p> <p>Zone Characteristics:</p> <p>Local keypad and detector will sound when this zone type is alarmed.</p>
Type 20 Arm-Stay	<p>Zone type 20 is a special-purpose zone type used with 5800 Series wireless pushbutton units.</p> <p>Zone Characteristics:</p> <ul style="list-style-type: none">• Exit delay regardless of the arming mode selected.• System is armed in the STAY mode when the zone is activated.• Zone number is sent to the central station as a user number when arming or disarming.
Type 21 Arm-Away	<p>Zone type 21 is a special-purpose zone type used with 5800 Series wireless pushbutton units.</p> <p>Zone Characteristics:</p> <ul style="list-style-type: none">• System is armed in the AWAY mode when the zone is activated.• Zone number is sent to the central station as a user number when arming or disarming.
Type 22 Disarm	<p>Zone type 22 is a special-purpose zone type used with 5800 series wireless pushbutton.</p> <p>Zone Characteristics:</p> <ul style="list-style-type: none">• Disarms the system when the zone is activated.
Type 23 No Alarm Response	<p>Zone type 23 can be used on a zone when a Powerline Carrier Device (e.g., X10) action is desired, but with no accompanying alarm (e.g., front door light).</p>
Type 24 Silent Burglary	<p>Zone type 24 is usually assigned sensors or contacts on exterior doors and windows where bells and/or sirens are NOT desired.</p> <p>Zone Characteristics:</p> <ul style="list-style-type: none">• Instant alarm, with NO audible indication when is armed in the AWAY, STAY, STAY NO DELAY, or AWAY NO DELAY mode.• Report sent to the central station. <p>Note: The Keypad beeps if the zone is faulted when system is disarmed and Chime mode is on.</p>

Data Field Descriptions

The following pages list all data fields in this Control (in numerical order). Use the blank programming form to record the data for this installation.

Note: Entering a number other than the one specified will give unpredictable results.

<p>20 INSTALLER CODE</p>	<p>Installer Code The Installer Code is used to enter the 4-digit Master Security Code. See "Master Code" in the <i>System Operation</i> section for procedure. SELECTIONS Enter 4 digits (0-9)</p>
<p>21 QUICK ARM ENABLE</p>	<p>Quick Arm Enable If enabled, security code is not required to arm the system. The user simply presses and holds down the AWAY or STAY key to arm. SELECTIONS 0 = do not allow quick arm 1 = allow quick arm</p>
<p>22 KEYPAD BACKLIGHT</p>	<p>Keypad Backlight Timeout This option allows the choice of either always backlighting the keypad or turning the backlighting off after 10 seconds of keypad inactivity. SELECTIONS 0 = no timeout; always backlight keys 1 = turn backlighting off after inactivity</p>
<p>23 FORCED BYPASS</p>	<p>Forced Bypass All zones bypassed by this function will be displayed after the bypass is initiated. UL installations: must be 0 (no forced bypass) SELECTIONS 0 = no forced bypass 1 = provide automatic bypass of all open (faulted) zones</p>
<p>24 RF HOUSE ID CODE</p>	<p>RF House ID Code The House ID identifies receivers and wireless keypads. If a 5804BD/5804BDV Transmitter is to be used, a House ID Code MUST be entered, and the keypad should be set to the same ID. SELECTIONS 00 = disable all wireless keypad usage 01-31 = House ID</p>
<p>25 X10 HOUSE CODE</p>	<p>Powerline Carrier Device (X10) House ID Powerline Carrier Devices require a House ID. This field identifies this House ID to the Control. The Powerline Carrier Devices are programmed in field *80. SELECTIONS 0 = A 3 = D 6 = G 9 = J # + 12 = M # + 15 = P 1 = B 4 = E 7 = H # + 10 = K # + 13 = N 2 = C 5 = F 8 = I # + 11 = L # + 14 = O</p>
<p>26 CHIME BY ZONE</p>	<p>Chime by Zone This option allows the installer to define the specific zones intended to chime when faulted while the system is in Chime mode. If enabled, these zones are defined in zone list 3 (see *81 <i>Zone List Menu Mode</i>). SELECTIONS 0 = no (chimes on fault of any entry/exit or perimeter zone when Chime mode is activated) 1 = yes (chimes on fault of those zones assigned to Zone List 3 when Chime mode on)</p>
<p>27 CLOCK DISPLAY</p>	<p>Real Time Clock Display Refer to the User's Manual for setting the clock time and date. SELECTIONS 0 = do not display the time 1 = display the time</p>

Data Field Descriptions

<p>29 DST MNTH STR/END</p>	<p>Daylight Savings Time Start/End Month Enter # + 10 for 10, # + 11 for 11, and # + 12 for 12. SELECTIONS 0 = do not display the time 1 = display the time</p>
<p>30 DST WEEK STR/END</p>	<p>Daylight Savings Time Start/End Month Enter the appropriate start and end weekend of the month. SELECTIONS 0 = disable 1 = first weekend of month 2 = second weekend 3 = third weekend 4 = fourth weekend 5 = last weekend 6 = next to last 7 = 3rd from last</p>
<p>31 SINGLE ALARM SND</p>	<p>Single Alarm sounding Per Zone (per armed period) This field applies only to burglary zones (zone response types 1-5, 10). It applies only to the bell and does not affect keypad sounds. UL installations: must be 0 (no limit) SELECTIONS 0 = no limit on alarm sounding per zone 1 = limit alarm sounding to once per arming period for a given zone</p>
<p>32 FIRE SND TIMEOUT</p>	<p>Sounder Timeout This Control complies with NFPA requirements for temporal pulse sounding of fire and carbon monoxide (CO) notification appliances. Temporal pulse sounding for a fire alarm consists of the following: 3 pulses – pause – 3 pulses – pause – 3 pulses. . . Temporal pulse sounding for a CO alarm consists of the following: 4 pulses – pause – 4 pulses – pause – 4 pulses – pause. . . SELECTIONS 0 = yes, sounder timeout after time programmed in field *33 1 = no sounder timeout; continue sounding until manually turned off</p>
<p>33 ALRM SND TIMEOUT</p>	<p>Alarm Bell Timeout This field determines whether the external sounder will shut off after a selected time, or allowed to continue until manually turned off. UL installations: must be set for a minimum of 4 min (option 1) SELECTIONS 0 = No timeout 1 = 4 minutes 2 = 8 minutes 3 = 12 minutes 4 = 16 minutes</p>
<p>34 EXIT DELAY TIME</p>	<p>Exit Delay The system will wait the time entered before sounding an alarm if the exit door is left open after the system has been armed. UL installations: Exit Delay must be set for a maximum of 60 seconds SELECTIONS 00-99 = exit delay in seconds</p>
<p>35 ENTRY DELAY 1</p>	<p>Entry Delay 01 The system will wait the time entered before sounding alarm upon entering if system is not disarmed. UL installations: The Entry Delay must be set for a maximum of 45 seconds SELECTIONS 00-99 = entry delay in seconds</p>

Data Field Descriptions

<p>36 ENTRY DELAY 2</p>	<p>Entry Delay 02 The system will wait the time entered before sounding alarm upon entering if the system is not disarmed. UL installations: must be set for a maximum of 45 seconds SELECTIONS 00-99 = entry delay in seconds</p>
<p>37 EXIT SMD/QK EXIT</p>	<p>Audible Exit Warning/Quick Exit Audible Exit Warning: Sound consists of slow continuous beeps until last 5 seconds, when it changes to fast beeps. The warning sound will end at the termination of exit delay. Quick Exit: If enabled, the user can restart the exit delay time after arming in STAY mode by entering the User Code and pressing the STAY key, or by pressing the STAY key if Quick Arm is enabled. This avoids having the user disarm then re-arm the system after allowing someone to enter or exit. SELECTIONS Exit Warning 0 = no exit warning sound 1 = provide exit warning sound when armed AWAY Quick Exit 0 = no quick exit 1 = allow quick exit</p>
<p>38 CONF ARMING DING</p>	<p>Confirmation of Arming Ding Confirmation of arming is provided by a 1/2 second external sounder “ding” that sounds when closing report is sent, or at the end of exit delay. If Option 2 is selected the external sounder “ding” occurs immediately after the system receives the RF transmission. SELECTIONS 0 = no ding 1 = confirmation ding after arming system 2 = confirmation ding after arming from RF button or RF keypad only</p>
<p>39 PWR UP PRV STATE</p>	<p>Power Up In Previous State When the system powers up armed, an alarm will occur 1 minute after arming if a zone is faulted, and any bypassed zones will be unbypassed. Note: If the previous state was Armed Away or Stay, the system will not respond to sensor changes for 1 minute. This allows time for sensors such as PIRs to stabilize. UL installations: must be 1 (power up in previous state) SELECTIONS 0 = always power up in a disarmed state 1 = assume the system status prior to power-down</p>

DIALER PROGRAMMING (*40–*50)

Fields *40, *41, *42: Enter up to the number of digits shown. Enter 0–9, # + 11 for ‘*’; # + 12 for ‘#’; # + 13 for a pause (2 seconds).

Notes: Whenever AAV is used, primary (Field *41) and secondary (Field *42) phone numbers should be preceded with the call waiting disable command. Otherwise, there is the possibility of connection of the third party to ReadyGuard Plus during AAV mode. The PABX phone number entered in field *40 is not dialed on GSM/IP (Digital Communication with AAV). However, it is used for dialing on Telco Line.

<p>40 PABX ACCESS CODE</p>	<p>PABX Access Code If fewer than 6 digits will be entered, exit by pressing [*]. To clear entries, press *40*. SELECTIONS PABX Access Code Enter up to 6 digits if PABX is needed to access an outside line.</p>
--	--

Data Field Descriptions



If the LRR/IP (Digital Communication with AAV) feature is used (options 5 in *55), there may be restrictions when dialing the numbers entered in *41, *42 and *46 (i.e.; #, *, pause may not be allowed, or phone number extensions may not be dialed, etc) depending on the service provider.

<p style="text-align: center;">41 PRIMARY TEL NUM</p>	<p>Primary Phone Number Enter the Primary Phone Number If fewer than 20 digits entered, exit by pressing [*]. To clear entries from field, press *41*. Note: Backup reporting (8 attempts are made to the secondary phone number if no kissoff is received after 8 attempts to the primary number) is automatic only if there is a secondary phone number (field *42). SELECTIONS Enter up to 20 digits.</p>
<p style="text-align: center;">42 SECOND TEL NUM</p>	<p>Secondary Phone Number Enter the Primary Phone Number If fewer than 24 digits entered, exit by pressing [*]. To clear entries from field, press *42*. See backup reporting note for field *41. SELECTIONS Enter up to 24 digits.</p>



All four digits of the Subscriber Account number must be entered in Fields *43 and *44. If ten-digit format is selected in *48 (option 5), all ten digits of the Subscriber Account number must be entered.

Fields *43 and *44:

Enter [*] as the fourth digit if a 3-digit account number (for 3+1 dialer reporting format) is used. Enter 0 as the first digit of a 4-digit account number for Nos. 0000–0999. Enter [*] as the fifth digit if a 4-digit account number (for 4+1, 4+2 CID®) is used. Exit field by pressing [*] if only 3 digits are used. See blank Programming Form for examples of account number entries. Enter digits 0–9; # +11=B; # +12=C; # +13=D; # +14=E; or # +15=F.

<p style="text-align: center;">43 PRIMARY ACCOUNT#</p>	<p>Primary Subscriber Account Number Enter the primary subscriber account number. To clear entries from field, press *43*. SELECTIONS Enter a 4 or 10- digit account number</p>
<p style="text-align: center;">44 SECNDRY ACCOUNT#</p>	<p>Secondary Subscriber Account Number Enter the primary subscriber account number. To clear entries from field, press *44*. SELECTIONS Enter a 4 or 10- digit account number</p>

Field *46: Enter up to 24 digits. Do not fill unused spaces. Enter 0-9, #+11 for ‘*’; #+12 for ‘#’; #+13 for a pause (2 seconds).

<p style="text-align: center;">46 FOLLOW ME PHONE#</p>	<p>“Follow Me Reminder” Phone Number This option allows the user to schedule a time driven message. When activated the system will dial the phone number programmed and deliver a voice message (custom words 72, 73 and 74). This option is only supported when the follow me feature is enabled in field *49 (option 6-9 or 10-13). If using the Follow Me Reminder feature, enter the phone number here. If fewer than 24 digits are entered, exit by pressing [*]. To clear entries from the field press *46*. The telephone message can be terminated (acknowledged) by pressing any key on the telephone keypad. Pressing any key on the local ReadyGuard Plus keypad will terminate (acknowledge) both the follow me and the local reminder announcements. Note: The follow me reminder announcement will be terminated if any other event requires the system to dial out or if an audible alarm has occurred. SELECTIONS Enter up to 24 digits.</p>
--	---

Data Field Descriptions

<p>47 PHONE SYS SELECT</p>	<p>Phone System Select This option is used to enter the correct type of phone dialing (pulse or tone), and to select the correct WATS line option for the Central Station. This option is used to activate the Speaker Phone option.</p> <p>Note: If using pulse dialing, you must enter the numbers slowly in order to allow the pulse dialer time to operate.</p> <p>SELECTIONS</p> <table border="1"> <thead> <tr> <th rowspan="2">Central Station</th> <th colspan="4">Dialing Mode</th> </tr> <tr> <th>Pulse</th> <th>Tone</th> <th>Pulse</th> <th>Tone</th> </tr> </thead> <tbody> <tr> <td>No WATS</td> <td>0 = No Speaker Phone</td> <td>1 = No Speaker Phone</td> <td>4 = Speaker Phone</td> <td>5 = Speaker Phone</td> </tr> <tr> <td>WATS</td> <td>2 = No Speaker Phone</td> <td>3 = No Speaker Phone</td> <td>6 = Speaker Phone</td> <td>7 = Speaker Phone</td> </tr> </tbody> </table>	Central Station	Dialing Mode				Pulse	Tone	Pulse	Tone	No WATS	0 = No Speaker Phone	1 = No Speaker Phone	4 = Speaker Phone	5 = Speaker Phone	WATS	2 = No Speaker Phone	3 = No Speaker Phone	6 = Speaker Phone	7 = Speaker Phone
Central Station	Dialing Mode																			
	Pulse	Tone	Pulse	Tone																
No WATS	0 = No Speaker Phone	1 = No Speaker Phone	4 = Speaker Phone	5 = Speaker Phone																
WATS	2 = No Speaker Phone	3 = No Speaker Phone	6 = Speaker Phone	7 = Speaker Phone																
<p>48 REP FRMT PRI/SEC</p>	<p>Report Format for Primary/Secondary This field is used to select the Primary and Secondary Report Format. (For an explanation of these formats, see the System Communication section of this manual).</p> <p>Notes: (1) The maximum number of alarm and alarm restore reports during one armed period is determined by field *:92. (2) If 3+1 dialer reporting is to be used, Enter * as the 4th digit of *:43 through *:44. (3) If Option 5 is selected a 10-digit account number must be entered in Fields *:43 or *:44. (4) Option 5 or 7 (ADEMCO Contact ID® Reporting) must be selected for AAV.</p> <p>SELECTIONS</p> <table border="1"> <thead> <tr> <th>Primary</th> <th>Secondary</th> </tr> </thead> <tbody> <tr> <td>See choices below</td> <td>See choices below</td> </tr> </tbody> </table> <p>0 = 3+1; 4+1 ADEMCO Low Speed Standard 1 = 3+1; 4+1 Radionics Standard 2 = 4+2 ADEMCO Low Speed Standard 3 = 4+2 Radionics Standard 5 = ADEMCO Contact ID® Reporting with 10-digit subscriber account number 6 = 4+2 ADEMCO Express 7 = ADEMCO Contact ID® Reporting with 4-digit subscriber account number 8 = 3+1; 4+1 ADEMCO Low Speed Expanded 9 = 3+1; 4+1 Radionics Expanded</p>	Primary	Secondary	See choices below	See choices below															
Primary	Secondary																			
See choices below	See choices below																			

Data Field Descriptions

<p style="text-align: center;">49 SPLIT/DUAL REP</p>	<p>Split/Dual Reporting This field is used to select a reporting option as follows: Enter: 0 - 5 when reporting to telephone receivers. 6 - 9 when reporting to a pager is desired 10 - 13 when reporting to an aux telephone receiver. Note: If you are installing a communications module that has voice communications capability (i.e.; GSMVLP), refer to Field *55 notes for additional information.</p> <p>Pager Report Format Options 6-9 send reports to the primary phone number, in a format defined in Field *48, and send reports to a pager, which has its phone number entered as the secondary phone number in Field *42. The pager report is a 7-digit code, with optional 16-digit prefix. For an explanation of the pager format, refer to the User Guide.</p> <p>Follow Me System Report Format Options 10-13 send reports to the primary phone number, in a format defined in Field *48, and sends voice message to the secondary phone number entered in Field *42. The message is a repeatable system status announcement. If the manual paging option has been programmed in Field *87, the message will repeat "system, system.....". The message can be terminated by pressing any key on the telephone keypad.</p> <table border="1" data-bbox="537 772 1455 1230"> <tr> <td>To Primary 0 = All reports 1 = Alarms, Restore, Cancel 2 = All except Open/Close, Test 3 = Alarms, Restore, Cancel 4 = All except Open/Close, Test 5 = All reports</td> <td>To Secondary None, unless primary fails, then all Others Open/Close, Test All All All</td> </tr> <tr> <td>To Primary 6 = All reports except Open/Close 7 = All reports 8 = All reports 9 = All reports except Open/Close</td> <td>To Paging Number Alarms, Open/Close ‡, Troubles Alarms, Troubles Alarms, Open/Close ‡, Troubles Open/Close ‡,</td> </tr> <tr> <td>To Primary 10 = All reports except Open/Close 11 = All reports 12 = All reports 13 = All reports except Open/Close</td> <td>To Follow Me System Phone Number Alarms, Open/Close ‡, Troubles Alarms, Troubles Alarms, Open/Close ‡, Troubles Open/Close ‡</td> </tr> </table> <p>‡ Will report Users 0, 5-8, and, if using wireless button-type devices, will report the zone number of the arm or disarm button 26-33. All other zones and users are not reported.</p>	To Primary 0 = All reports 1 = Alarms, Restore, Cancel 2 = All except Open/Close, Test 3 = Alarms, Restore, Cancel 4 = All except Open/Close, Test 5 = All reports	To Secondary None, unless primary fails, then all Others Open/Close, Test All All All	To Primary 6 = All reports except Open/Close 7 = All reports 8 = All reports 9 = All reports except Open/Close	To Paging Number Alarms, Open/Close ‡, Troubles Alarms, Troubles Alarms, Open/Close ‡, Troubles Open/Close ‡,	To Primary 10 = All reports except Open/Close 11 = All reports 12 = All reports 13 = All reports except Open/Close	To Follow Me System Phone Number Alarms, Open/Close ‡, Troubles Alarms, Troubles Alarms, Open/Close ‡, Troubles Open/Close ‡
To Primary 0 = All reports 1 = Alarms, Restore, Cancel 2 = All except Open/Close, Test 3 = Alarms, Restore, Cancel 4 = All except Open/Close, Test 5 = All reports	To Secondary None, unless primary fails, then all Others Open/Close, Test All All All						
To Primary 6 = All reports except Open/Close 7 = All reports 8 = All reports 9 = All reports except Open/Close	To Paging Number Alarms, Open/Close ‡, Troubles Alarms, Troubles Alarms, Open/Close ‡, Troubles Open/Close ‡,						
To Primary 10 = All reports except Open/Close 11 = All reports 12 = All reports 13 = All reports except Open/Close	To Follow Me System Phone Number Alarms, Open/Close ‡, Troubles Alarms, Troubles Alarms, Open/Close ‡, Troubles Open/Close ‡						
<p style="text-align: center;">50 15 SEC DIAL DLY</p>	<p>15-Second Dialer Delay (Burglary) If enabled, provides delay of burglary report to the central station, and allows time for the subscriber to avoid a false alarm transmission. The delay applies only to zone type 3 and 5 alarms and not to zone type 24 alarms (silent burglary) or to 24-hour zone types 6, 7, and 8 (silent panic, audible alarm, auxiliary alarm), which are always sent as soon as they occur. UL installations: must be 0 (no delay)</p> <p>SELECTIONS 0 = no dialer delay 1 = provide 15-second delay of burglary alarm report when armed away</p>						
<p style="text-align: center;">51 PERIOD TEST REP</p>	<p>Periodic Test Report Test report code entered in field *64 is sent.</p> <p>SELECTIONS 0 = no test report 1 = once every 24 hrs 2 = weekly 3 = once every 30 days</p>						

Data Field Descriptions

52 TEST REP OFFSET	<p>First Test Report Offset Select the time for the first report following pwer-up/programming or downloading.</p> <p>SELECTIONS 0 = 24 hrs after exit program mode or download 1 = 6 hours after exit program mode or download 2 = 12 hrs after exit program mode or download 3 = 18 hrs after exit program mode or download</p>
53 SESCOA/RADIONICS	<p>Sescoa/Radionics Select If disabled, selects Radionics, which uses hexadecimal 0-9, B-F reporting. If enabled, selects SESCOA, which uses only numeric reporting (0-9). Select 0 for all other formats.</p> <p>SELECTIONS 0 = Radionics (0-9, B-F reporting) 1 = SESCOA (0-9 only reporting)</p>
54 LACK OF USAGE	<p>Lack of Usage Notification If enabled, notifies the central station if an end user is not operating their security system by sending a System Inactivity report 654. The report will be sent only to the Primary phone number and only if Contact ID® format was selected.</p> <p>Note: The report will follow the *49 = 0 rules, no matter which selection was made in *49.</p> <p>SELECTIONS 0 = Disabled 2 = 7 days 4 = 90 days 6 = 365 days 1 = 1 day 3 = 27 days 5 = 180 days</p> <p>Note: There is no local annunciation indicating that this report has been sent to the Central Station.</p>

Field *55: If AAV is enabled in *91, depending on Communication Channels programmed in *55, only the Reporting options from the table below are available. They should be programmed as described in Dynamic Signaling (field *77). If AAV is disabled in field *91, reporting option 5 is not available.



If Follow Me System of Pager features are selected, AAV will not be available even if enabled in *91 UNLESS option 5 is selected in *55 (Radio only). If option 5 is selected in *55, AAV will be established on the primary channel because Follow me System and Pager are not available on the radio's audio channel.

The following table shows the only valid combinations of communication channels and reporting options. It is the responsibility of the installer to ensure that a valid combination is programmed.

Reporting Option	AAV Enabled?	*55 Communication Channel
Primary Phone only	Y/N	0 = Telco Line only (no radio) (see Note 1)
Redundant reports to both channels	Y/N	1 = LRR/IP (Digital Communication only) and Telco Line (see Note 1)
Primary Phone is the preferred channel	Y/N	1 = LRR/IP (Digital Communication only) and Telco Line (see Note 1)
LRR/IP is the preferred channel	Y/N	1 = LRR/IP (Digital Communication only) and Telco Line (see Note 1)
LRR/IP Only	N Y	3 = LRR/IP (Digital Communication only) (no Telco Line) (see Notes 2 & 3) 5 = LRR/IP (Digital Communication w/AAV) (Telco Line connections for 2-way voice session only, if applicable) (see Notes 2, 3, 4)

NOTES

- AAV mode can be established only on Telco Line.
- Follow me System and Follow me Reminder and Pager features are not supported. These features will not work if selected in *49.
- Speaker Phone and Remote Phone Access are not available. These features should be disabled in *47 and *91. Download over the Phone Line feature is also unavailable.
- AAV mode can be established only on LRR/IP (Digital Communication with AAV Capabilities)

Legend

LRR/IP (Digital Communication only) = Digital GSM Communication Channel

LRR/IP (Digital Communication with AAV) = GSM Communication Channel with voice capabilities (a radio with voice capabilities is required to use the voice capabilities)

Telco Line = Land Phone Line

Data Field Descriptions

<p style="text-align: center;">55 REPORT CHANNELS</p>	<p>Reporting Channels This option is used to enable/disable Central Station reporting via the LRR/IP Communications Device (See Field *77). Upload/ download via the Internet IP module is not affected by this entry. The option specifies the channel that the control will use when sending reports to the Central Station (Follow Me Phone and Pager). Select some or all channels as required.</p> <p>IMPORTANT NOTE: Make sure that selected channels are physically available and functional.</p> <p>SELECTIONS 0 = Telco Line (no Radio) 1 = LRR/IP (Digital Communication only) and Telco Line 3 = LRR/IP (Digital Communication only) (no Telco Line) 5 = LRR/IP (Digital Communication with AAV) (Telco Line Connections for 2-way voice session only, if applicable)</p>
<p style="text-align: center;">58 RF JAM DETECTION</p>	<p>RF Jam Detection For Event Logging, Option 2 must be selected. If the control detects an RF Jam condition, a "FAULT" message appears for zone 90. The Contact ID® code for RF Jam is 344.</p> <p>SELECTIONS 0 = no jam detection 1 = RF jam detection with event logging, but no central station report 2 = RF jam detection with event logging and with central station report (if trouble/restore report is enabled in fields *60, *71)</p>

SYSTEM STATUS AND RESTORE REPORT CODES PROGRAMMING (*59 – *76, & *89)

Report Codes can be programmed using the interactive *56 Enhanced Zone Programming Mode, or entered in data fields *59-*76 and *89. Use the following guidelines when programming report codes. The actual report code digits entered depend upon the particular installation, and should be in agreement with you and the Central Station that will receive the signals. **With a 3+1 or 4+1 Standard Format:** Enter a code in the first box: 1–9, A, B, C, D, E, or F. Enter "#+10" for A (reports a "0" on some receivers), "#+11" for B, "#+12" for C, "#+13" for D, "#+14" for E, "#+15" for F. Entering "0" in the *first* box will disable a report. Entering "0" in the second box results in automatic advance to the next field.

With an Expanded or 4+2 Format: Enter codes in *both* boxes (1st and 2nd digits) for 1–9, or A–F, as described above. Entering "0" in the first box will disable a report. Entering "0" in the second box will eliminate the expanded message for that report.

With ADEMCO Contact ID® Reporting: Enter a digit in the first box to enable the zone to report. Use a different digit for each zone until you have used up available digits. If the number of zones exceeds the number of available digits, begin with digit 1 again. This is an "enabling" code only and is not the actual code sent to the central station office. Entries in the second boxes will be ignored. For system status (non-alarm) codes, enter a "1" in the first box for all the system conditions you want to send to the central station. A "0" in the first box disables the report.

Data Field Descriptions

SYSTEM STATUS REPORT CODES (*59–*68)

<p>59 EXIT ERROR REP</p>	<p>Exit Error Report Code (See notes above) If the system is armed and an entry/exit or interior zone is still open after the exit delay time has expired, an alarm will sound at the keypad and external sounder. If the system is disarmed before the end of the entry delay that immediately follows, the alarm sounding will stop and no message will be sent to the central station. The keypad will display “CA Canceled Alarm”. If an Exit Error report code is selected in this field and the system is not disarmed before the end of the entry delay, and an entry/exit or interior zone is still open, an “exit alarm” message will be sent to the central station. The keypad will display “EA Exit Error”, and the alarm sounding will continue until the system is disarmed (or timeout occurs). An Exit Alarm condition will also result if a fault occurs in an exit or interior zone within 2 minutes following the end of the exit delay, and an “Exit Alarm” message will be sent to the central station. If Contact ID® format has been programmed, the message will contain the zone number and error code 374 (Trouble–Exit Error). If 4+2 format is used, the digit entered in this field will be sent followed by the second digit of the programmed alarm code for that zone. If 3+1 or 4+1 format is used, only the digit entered in this field will be sent. This message will go to the Primary Phone Number. No restore message will be sent under any of these conditions. If “0” is entered in this field, no special message will be sent, only the regular alarm and alarm restore code for the zone.</p>
<p>60 TROUBLE REP CODE</p>	<p>Trouble Report Code (See notes above) A Trouble Report will be sent if a zone goes into trouble.</p>
<p>61 BYPASS REP CODE</p>	<p>Bypass Report Code (See notes above) A Bypass Report will be sent when a zone is manually bypassed.</p>
<p>62 AC LOSS REP CODE</p>	<p>AC Loss Report Code (See notes above) Timing of the AC Loss Report is random with up to a 4-hour delay. If AC restores before the report goes out, there is no AC restore report.</p>
<p>63 LOW BAT REP CODE</p>	<p>Low Battery Report Code (See notes above) Low Battery Report will be sent when a low battery condition exists in the system’s standby battery.</p>
<p>64 TEST REPORT CODE</p>	<p>Test Report Code (See notes above) Test Report is sent periodically to test that the communicator and phone lines are operational (frequency of report is selected in field *51).</p>
<p>65 OPEN REPORT CODE</p>	<p>Opening Report Code (See notes above) This report is sent upon disarming of the system. If expanded or 4+2 reporting is selected, the 2nd digit = user number.</p>
<p>66 AWAY/STAY REPORT</p>	<p>Arm Away Report Code (See notes above) This option allows for independent programming of Away and Stay reports. If expanded or 4+2 reporting is selected, the 2nd digit = user number. Note: OPEN reports are not sent if the associated closing report is not enabled.</p>
<p>67 RF TRANS LB REP</p>	<p>RF Transmitter Low Battery Report Code (See notes above) This report is sent in the event that a wireless transmitter low battery condition exists.</p>
<p>68 CANCEL REP CODE</p>	<p>Cancel Report Code (See notes above) This report is sent upon disarming of the system after an alarm condition was reported.</p>

Data Field Descriptions

RESTORE REPORT CODES (*70–*76)

<p>70 ALARM RES REPORT</p>	<p>Alarm Restore Report Code (See notes above) 1st digit is sent when the zone that caused an alarm is restored to its non-faulted condition. If expanded or 4+2 reporting is selected, 2nd digit is automatically sent as the 2nd digit of the zone alarm report code programmed in field *56.</p>
<p>71 TROUBLE RES REP</p>	<p>Trouble Restore Report Code (See notes above) Report is sent when a trouble in a zone is restored.</p>
<p>72 BYPASS RES REP</p>	<p>Bypass Restore Report Code (See notes above) Report is sent when a zone that has been bypassed is unbypassed.</p>
<p>73 AC RESTORE REP</p>	<p>AC Restore Report Code (See notes above) Report is sent when AC power has been restored after an AC power outage.</p>
<p>74 LO BAT RES REP</p>	<p>Low Battery Restore Report Code (See notes above) Report is sent when a system low battery condition is restored to normal.</p>
<p>75 RF LOBAT RES REP</p>	<p>RF Transmitter Low Battery Restore Report Code (See notes above) Report is sent when a transmitter that previously sent in a “low battery” message has sent a message indicating it no longer has a low battery condition.</p>
<p>76 TEST RES REPORT</p>	<p>Test Restore Report Code (See notes above) Report is sent when the test mode is exited. A restore code entered here will cause a restore message to be sent when Test mode is exited.</p>

Data Field Descriptions



To ensure that the ReadyGuard Plus properly transmits its reports to the Central Station via the proper channel you must program a Primary Phone Number in Field *41 and/or activate/deactivate the LRR/IP Communications Module in Field *55. The 15-Second Dialer Delay (Burglary), programmed in Field *50 is independent of the delay selected in Field *77 and applies to both telephone and communications device.

DYNAMIC SIGNALING DELAY/DYNAMIC SIGNALING PRIORITY FIELD *77

Two report channels are used by the ReadyGuard Plus to support the LRR/IP communications device and dynamic signaling. For the primary channel the device can communicate via AlarmNet GSM/IP or Cellular communications devices. Secondary phone is not affected by dynamic signaling scheme. Two programming options are used to define dynamic signaling behavior. Field *55 is used to enable/disable the LRR/IP communications device and allows it to supervise the communications module. The two-digit option programmed in Field *77 defines how dynamic signaling will function. The Dynamic signaling options are shown as follows:

Reporting Option	Enable/Disable Device (Field *55)	Dynamic Signaling Delay/Dynamic Signaling (Field *77)
Primary Phone only Report is sent to Primary phone with No Dynamic Signaling Delay	0 = Disable	1st Entry * = Enter any digit 2nd Entry * = Enter any digit except "2" as the second entry
LRR/IP only Report sent to communications device with No Delay	3 = Enable OR 5 = Enable	1st Entry * = enter any non zero digit as a first entry 2nd Entry 2 = LRR/IP reporting only
Redundant reports to both channels Report independently goes to the Primary phone and LRR/IP communications device with No Delay	1 = Enable	1st Entry 0 = Redundant reporting on dialer and communication device 2nd Entry * = enter any number as a second entry
Primary Phone is the preferred channel First report is sent to the primary phone. If primary phone fails to deliver report within the delay window defined in *77 all following reports go to both primary phone and communications device with no delay. When report goes through the primary phone, the control stops reporting to communications device. Note: The delay must be set to at least 30 seconds if Remote Phone Control and/or AAV is enabled.	1 = Enable	1st Entry * = Enter a delay for the first entry 2nd Entry 0 = Primary Dialer is the preferred channel
LRR/IP is the preferred channel First report is sent to the communications device. If device fails to deliver report within the time window defined in *77, all following reports go to both LRR/IP device and primary phone with no delay. When report goes through the LRR/IP device, the control stops reporting to primary phone.	1 = Enable	1st Entry * = Enter any delay for the first entry 2nd Entry 1 = LRR/IP is the preferred channel



If the LRR/IP communications device is selected as the preferred channel option and the control detects a communication failure or supervision failure, reports will be sent to the Primary Phone without any delay.

Data Field Descriptions

<p style="text-align: center;">77 DYNAMIC SIG OPTS</p>	<p>Dynamic Signaling Delay/ Dynamic Signaling Priority</p> <p>1st Entry Enables Dynamic Signaling Delay and allows you select the time-out period the panel will wait for acknowledgment from the first reporting destination (preferred channel) before it attempts to send a message to the second destination. This delay is per message. Delays can be selected from 0 to 225 seconds, in 15-second increments. If 0 is entered, the control panel will send redundant reports to both Primary Dialer and the LRR/IP communications device. For LRR radio reporting enter any non-zero digit for the first entry.</p> <p>2nd Entry The second entry determines the alternate Central Station communication path that will be initiated after the time-out period. It allows you to select the (Dynamic Signaling Priority) preferred reporting channel.</p> <p>Notes: (1) You must also enable/disable LRR/IP Device in field *55. (2) If Remote Phone Access is enabled, and Primary Phone is used as a Preferred Channel, Dynamic Signaling Delay should be at least 30 sec in order to prevent duplicate reports. (3) For UL installations Dynamic Signaling Delay cannot exceed 15 sec. If Primary Phone is used as a Preferred Channel, duplicate reports may sent.</p> <p>SELECTIONS</p> <p>1st Entry (delay before switching Central Station reporting path)</p> <table style="width: 100%; border: none;"> <tr> <td style="width: 33%;">0 = Redundant reporting on dialer and LRR/IP comm..device</td> <td style="width: 33%;">4 = 60 seconds</td> <td style="width: 33%;">#10 = 150 seconds</td> </tr> <tr> <td>1 = 15 seconds</td> <td>5 = 75 seconds</td> <td>#11 = 165 seconds</td> </tr> <tr> <td>2 = 30 seconds</td> <td>6 = 90 seconds</td> <td>#12 = 180 seconds</td> </tr> <tr> <td>3 = 45 seconds</td> <td>7 = 105 seconds</td> <td>#13 = 195 seconds</td> </tr> <tr> <td></td> <td>8 = 120 seconds</td> <td>#14 = 210 seconds</td> </tr> <tr> <td></td> <td>9 = 135 seconds</td> <td>#15 = 225 seconds</td> </tr> </table> <p>2nd Entry</p> <p>0 = Primary Dialer Preferred Channel 1 = LRR/IP Preferred Channel 2 = LRR/IP reporting only</p>	0 = Redundant reporting on dialer and LRR/IP comm..device	4 = 60 seconds	#10 = 150 seconds	1 = 15 seconds	5 = 75 seconds	#11 = 165 seconds	2 = 30 seconds	6 = 90 seconds	#12 = 180 seconds	3 = 45 seconds	7 = 105 seconds	#13 = 195 seconds		8 = 120 seconds	#14 = 210 seconds		9 = 135 seconds	#15 = 225 seconds
0 = Redundant reporting on dialer and LRR/IP comm..device	4 = 60 seconds	#10 = 150 seconds																	
1 = 15 seconds	5 = 75 seconds	#11 = 165 seconds																	
2 = 30 seconds	6 = 90 seconds	#12 = 180 seconds																	
3 = 45 seconds	7 = 105 seconds	#13 = 195 seconds																	
	8 = 120 seconds	#14 = 210 seconds																	
	9 = 135 seconds	#15 = 225 seconds																	
<p style="text-align: center;">78 PROG TONE GEN TM</p>	<p>Programmable Tone Generation Time</p> <p>This field is used to set the time delay between when a connection is established on a Radio (digital communication with voice capabilities) session to when the 2100 Hz “training” tone is terminated. Enter any digit between 00 and 99.</p> <p>Note: This field only applies when a GSMVLP radio is installed in the control. Otherwise, enter “00” to disable.</p> <p>SELECTIONS</p> <p>00 = Disabled 01-09 = 100-900 ms 10-99 = 1.0 – 9.9 secs.</p>																		
<p style="text-align: center;">86 MULTI-MODE EMAIL</p>	<p>Multi-mode (E-mail notification)</p> <p>Note: RIS is always enabled</p> <p>Enable if using AlarmNet Remote Services e-mail notification (multi-mode) feature. The address(es) used must also be enabled in the AlarmNet communication device. For more information refer to the instructions provided with the communications device being installed.</p> <p>SELECTIONS</p> <p>0 = Disable multi-mode devices (RIS enabled) 1 = Enable multi-mode device address #6 only (RIS enabled) 2 = Enable multi-mode device address #7 only (RIS enabled) 3 = Enable multi-mode addresses #6 & #7 (RIS enabled)</p>																		

Data Field Descriptions

<p>87 AUX FUNC 1BTN PG</p>	<p>AUX Function/1-Button Paging If "0" is entered, user can define a macro function for the AUX key. See user manual for description of the use of this key. If "1" is entered, you must also select an option in field *49. The options are 6-9 for the pager or 10-13 for the follow me system announcement. The actual pager message is 999-9999. Note that the hyphen may not be displayed, depending on the pager service. The manual follow me system announcement is a repeatable "System, System.....". Note: A macro cannot be run from the Test mode. SELECTIONS 0 = Aux key performs defined function (macro) 1 = Aux key sends a voice message to Follow Me system phone number</p>
<p>88 PAGER CHARACTERS</p>	<p>Pager Characters If entered, these digits will appear in front of the 7-digit pager message sent by the control (either upon a system event or upon pressing the AUX key, if programmed for paging), and during latch key report (if enabled during scheduling). These digits can consist of a PIN number, account number, pauses or special digits needed by the pager (these types of characters are not displayed), or any other characters the user chooses that will be displayed (e.g., using a character code to distinguish between control panel messages and other pager messages). You do not need to fill all 16 digits. Press [*] + next field number to exit the field. To clear the field, press *88*. Notes: 1. The AUX key Paging feature is enabled in field *87. For an explanation of the pager format, refer to the User Guide. 2. Verify that the pager supports [*] and [#] characters before using them. Some pagers require an additional delay [pause] in order to receive the entire message. SELECTIONS Enter up to 16 digits that will appear in front of the 7-digit pager message. Enter [#] + [11] for "*" Enter [#] + [12] for "#" Enter [#] + [13] for 2-second pause</p>
<p>89 EVNT LOG 80% REP</p>	<p>Event Log 80% Full Report Code (See notes above) If an Event Logging selection is made in field *90, a message can be sent to the central station receiver when the log is 80% full. If the log becomes full, a new message will overwrite the oldest message in the log. Note: All control and readout from the log, aside from the selection made by the installer in field *90, is accomplished via the downloader.</p>
<p>90 EVNT LOG OPTIONS</p>	<p>Event Logging Options The system has the ability to record various events in a history log (84-event capacity). The types of events to be logged can be selected as indicated. At any time, the downloader operator can then upload the log and view or print out all or selected categories of the log. The log can also be cleared by the download operator. The display/printout at the central station will show the date, time, event, and description of the occurrences. Note: System messages are logged when any non-zero selection is made. Example: To select "Alarm/Alarm Restore" and "Open/Close," enter 9 (1 + 8); to select all events, enter #15. Default "3" = alarm/alarm restore (1) plus trouble/trouble restore (2). SELECTIONS 0 = No event logging 1 = log Alarm/Alarm Restore 2 = log Trouble/Trouble Restore 4 = log Bypass/Bypass Restore 8 = log Open/Close x = log combination of events (add value of entries)</p>

Data Field Descriptions

<p>91 AAV/REM PHM CTRL</p>	<p>Audio Alarm Verification (AAV)/ Remote Phone Control This option is used to enable the Audio Alarm Verification and/or the Remote Phone Control features.</p> <p>Notes: (1) In order to activate the Remote Phone Control feature and defeat an answering machine, ensure that the correct ring detection count ("15") has been programmed in field *95. (2) Remote phone session will be terminated if a report must be sent. (3) Alarm Audio Verification will only function when Contact ID® is selected. AAV cannot be used for UL installations. (4) If an alarm will be reported to primary and secondary phone numbers, AAV can only function via the secondary number. (5) If an alarm will be reported to a pager (6-8 in field *49), or to a follow me phone number (10-12 in field *49) AAV cannot be used. (6) If AAV is selected and LRR/IP communications device is enabled, you must enter "0" (primary dialer preferred channel) as the second entry in Field *77. (7) AAV and Remote Phone Control features can only be used if the central station or remote phone supports DTMF commands.</p> <p>SELECTIONS 0 = none 1 = AAV and remote phone control 2 = remote phone control only 4 = AAV only</p>
<p>92 # REPS ARMED PER</p>	<p>Number of Reports In Armed Period This option can be used to limit the number of messages (alarm & alarm restore reports) sent by the ReadyGuard Plus to the central station in an armed period. UL installations: must be 1 (unlimited reports)</p> <p>SELECTIONS 0 = reports limited to a total of 10 1 = unlimited number of reports</p>
<p>93 FLEXBLE CALLBACK</p>	<p>Flexible Callback Note: This feature only applies to telephone downloading If enabled, the control will ignore the last 1, 2, or 3 digits of the programmed callback number (field *94) during a single download session. This allows the download operator to temporarily change the callback phone number by the number of digits selected, which allows the control to call back similar, but different numbers during a single session. For example, if downloading to a large number of controls, the operator can command the controls to call back phone numbers 555-1111, 555-1112, 555-1113, etc., thus spreading the communications among several computers.</p> <p>SELECTIONS 0 = no flexible callback 1 = last digit flexible 2 = last 2 digits flexible 3 = last 3 digits flexible</p>

DOWNLOAD INFORMATION (*94, *95)

<p>94 DOWNLOAD PHONE #</p>	<p>Download Call Back Phone Number This is the phone number the control will use to call back the downloading computer. Do not fill unused spaces. End field by pressing *. To clear entries from field, press *94*.</p> <p>SELECTIONS Enter up to 20 digits as follows: 0-9, # +11 for "*", # + 12 for "#", # + 13 for a pause.</p>
--	--

Data Field Descriptions

<p>95 RING DET COUNT</p>	<p>Ring Detection Count for Downloading/Remote Phone Control Mode</p> <p>Enter "15" to select defeat answering machine mode. If an answering machine is on the premises, you need to dial the premises and hang up on the first ring. Wait at least five (5) seconds (but no more than 22 seconds) and dial the premises phone number again. The control will pick up and announce "SYSTEM ENTER CODE" every three seconds.</p> <p>Note: To enter a number higher than 9 you must first press the [#] key.</p> <p>SELECTIONS</p> <p>0 = disable station initiated download and remote phone 1-14 = number of rings before control picks up phone line 15 = defeat answering machine</p>
-------------------------------------	--

*56 Enhanced Zone Programming Mode

This is an interactive menu mode that is used to program zone numbers, zone types, alarm and report codes, and to identify the type of loop input device. This mode can also be used for entering 5800 Series transmitter serial numbers.

Note: There are two methods for entering transmitter serial numbers. The first method is by using *56 Enhanced Zone Programming Mode (described below). The second method is by using *83 Enhanced Sequential Mode. Note that the *83 Enhanced Sequential Mode requires that all zone information first be entered using *56 Enhanced Zone Programming mode.

While in Program mode, press *56 to enter Zone Programming Menu Mode. The following explains the *56 prompts in detail. The left column identifies the prompts and the right column provides an explanation of the entries and lists the available entries.



1. Prompts d, E, F, 1A, 1b, 1C, 1d, 1E, AND 1F do not apply to Zones 92, 95, 96 or 99.
2. Prompts d, E, F, 1A and 1b do not apply to Zone 1 (hardwire zone).

<div style="border: 1px solid black; padding: 5px; margin: 5px;"> <p>AD1 ZONE NUMBER</p> </div>	<p>Zone Number Enter the 2-digit zone number to be programmed and the Voice Descriptor for the selected zone number will be announced, if it is programmed. Press [*] to advance to the next field. Pressing 00 exits mode, upon which the prompt "56" blinks, indicating the mode is inactive. Press [*] + any field number to go to that field.</p> <p>SELECTIONS</p> <table style="width: 100%; border: none;"> <tr> <td style="width: 50%;">00 = Exit Zone Programming</td> <td style="width: 50%;">26-41 = Button zones (only)</td> </tr> <tr> <td>01 = Hardwire Zone</td> <td>92 = Duress</td> </tr> <tr> <td>02-25 = RF zones (only)</td> <td>95, 96, 99 = Panic zones</td> </tr> </table>	00 = Exit Zone Programming	26-41 = Button zones (only)	01 = Hardwire Zone	92 = Duress	02-25 = RF zones (only)	95, 96, 99 = Panic zones												
00 = Exit Zone Programming	26-41 = Button zones (only)																		
01 = Hardwire Zone	92 = Duress																		
02-25 = RF zones (only)	95, 96, 99 = Panic zones																		
<div style="border: 1px solid black; padding: 5px; margin: 5px;"> <p>b ZONE TYPE</p> </div>	<p>Zone Type Each zone must be assigned to a 2-digit zone type, which defines the way in which the system responds to faults in that zone. Press [*] to advance to the next field or [#] to return to previous prompt.</p> <p>Notes If 00 is accepted as a zone type, save the 00 zone type and advance to the confirm delete prompt (F).</p> <p>SELECTIONS</p> <table style="width: 100%; border: none;"> <tr> <td style="width: 50%;">00 = Not Used</td> <td style="width: 50%;">09 = Fire without verification</td> </tr> <tr> <td>01 = Entry/Exit #1</td> <td>10 = Interior w/Delay</td> </tr> <tr> <td>02 = Entry/Exit #2</td> <td>14 = Carbon Monoxide</td> </tr> <tr> <td>03 = Perimeter</td> <td>20 = Arm-Stay</td> </tr> <tr> <td>04 = Interior Follower</td> <td>21 = Arm-Away</td> </tr> <tr> <td>05 = Trouble Day/Alarm Night</td> <td>22 = Disarm</td> </tr> <tr> <td>06 = 24 Hr Silent</td> <td>23 = No Alarm Response</td> </tr> <tr> <td>07 = 24 Hr Audible</td> <td>24 = Silent Burglary</td> </tr> <tr> <td>08 = 24 Hr Aux</td> <td></td> </tr> </table>	00 = Not Used	09 = Fire without verification	01 = Entry/Exit #1	10 = Interior w/Delay	02 = Entry/Exit #2	14 = Carbon Monoxide	03 = Perimeter	20 = Arm-Stay	04 = Interior Follower	21 = Arm-Away	05 = Trouble Day/Alarm Night	22 = Disarm	06 = 24 Hr Silent	23 = No Alarm Response	07 = 24 Hr Audible	24 = Silent Burglary	08 = 24 Hr Aux	
00 = Not Used	09 = Fire without verification																		
01 = Entry/Exit #1	10 = Interior w/Delay																		
02 = Entry/Exit #2	14 = Carbon Monoxide																		
03 = Perimeter	20 = Arm-Stay																		
04 = Interior Follower	21 = Arm-Away																		
05 = Trouble Day/Alarm Night	22 = Disarm																		
06 = 24 Hr Silent	23 = No Alarm Response																		
07 = 24 Hr Audible	24 = Silent Burglary																		
08 = 24 Hr Aux																			
<div style="border: 1px solid black; padding: 5px; margin: 5px;"> <p>E REPORT CODE</p> </div>	<p>Report Code Enter the report code for this zone. The report code consists of 2 hexadecimal digits, each in turn consisting of 2 numerical digits. For example, for a report code of "3C", enter [0][3] for "3" and [1][2] for "C". If this is Zone 95, 96 or 99, the system skips to the VOICE DESCRIPTOR prompt (1C). Press [*] to advance to the next field or [#] to return to previous prompt.</p> <p>Note: If "00" is entered as the first digit, there will be no report for that zone.</p> <p>SELECTIONS</p> <table style="width: 100%; border: none;"> <tr> <td style="width: 33%;">00-09 = 0-9</td> <td style="width: 33%;">12 = C</td> <td style="width: 33%;">14 = E</td> </tr> <tr> <td>10 = A</td> <td>13 = D</td> <td>15 = F</td> </tr> <tr> <td>11 = B</td> <td></td> <td></td> </tr> </table>	00-09 = 0-9	12 = C	14 = E	10 = A	13 = D	15 = F	11 = B											
00-09 = 0-9	12 = C	14 = E																	
10 = A	13 = D	15 = F																	
11 = B																			

*56 Enhanced Zone Programming Mode

<p style="text-align: center;">d INPUT TYPE</p>	<p>Input Type Enter the input type for the transmitter assigned to this zone. Refer to the transmitter's instructions for input types of each transmitter. Press [*] to advance to the next field or [#] to return to previous prompt.</p> <p>Notes: (1) RF type transmitters must remain within range of the receiver, otherwise a supervision failure signal will occur. (2) UR and BR type transmitters may be carried off premises (out of range without causing a supervision failure). (3) Zones 2-25 should be assigned Input Type 3 or 4. Zones 26-41 should be assigned Input Type 5 only.</p> <p>SELECTIONS 3 =RF (supervised RF) – sends periodic check-in signals, faults, restore and low battery signals 4 = UR (unsupervised RF) – sends same as “RF” type, but control does not supervise the check-in signals 5 = BR (button type) – sends only fault and low battery signals; does not send restores or check-in signals</p>
<p style="text-align: center;">E LOOP#/AUTOLEARN</p>	<p>Loop Number or Loop and Serial Number This prompt can be used to enroll the transmitter loop number and serial number via RF transmission (if using RF Learning) or the loop number can be enrolled manually. If using the RF Learning Mode, there is no need to manually enter a loop number. Proceed directly to RF Learning</p> <p>Notes: (1) BR type devices cannot be enrolled by using UR or RF type. Likewise, UR or RF type devices cannot be enrolled by using a BR type device. There is a 52-second time-out for RF enrolling. At the end of the time-out, the system returns to the INPUT TYPE prompt (d). If enrolled, the loop number and “LEARNED” are displayed. (2) Once encrypted (high-security) devices have been enrolled they must be activated. Refer to the device's Installation Instructions to activate the High-Security Mode.</p> <p>RF Learning - For BR type devices (device type 5), 2 transmissions (2 key depressions) at least 5 seconds apart will be required. Two beeps will sound after the second transmission, confirming that the loop number and serial number have been learned. For all other device types, four (4) transmissions are required (fault, restore and fault, restore). A single beep will sound after the second transmission confirming that the loop and serial number have been captured. Following the fourth transmission, the system will confirm that the loop number and serial number have been learned and announce the Voice Descriptor for the zone, if it is programmed, followed by two beeps. Press [*] to continue.</p> <p>Manual Entry - Enter the desired loop number and press [*] to continue (see the transmitter's Installation Instructions for specific loop designations).</p> <p>Note: The loop number can be changed even if the zone has already been entered. Care should be taken when using this feature as it has the capability to make zones inoperable by creating a mismatch of a working serial number/loop number combination. This should be re-confirmed if the loop number is changed.</p> <p>“LEARNED” indicates that the zone's serial number has already been enrolled.</p> <p>SELECTIONS 1-4 = loop number for the zone of the transmitter being entered. 0 + [*] = continue to DELETE ZONE PARAMETERS CONFIRMATION prompt (F) [*] = continue to the ENROLL MODE prompt (1A) if not entered, or VOICE DESCRIPTOR prompt if already entered [#] = return to previous prompt</p>

*56 Enhanced Zone Programming Mode

<p style="text-align: center;">F DELETE ZONE</p>	<p>Delete Zone Parameters Confirmation This function deletes either the serial number or all zone information that is programmed for the zone. If "00" was entered in the zone type, the confirmation of the delete request will delete all information associated with the zone currently being programmed. If "0" was entered in the loop number, the confirmation of the delete request will delete the serial number of the zone currently being programmed.</p> <p>SELECTIONS 0 = discard the delete request 1 = confirm requested delete</p> <p>Note: If 00 was entered as a zone type in prompt (b), 00 will be retained and system will advance to prompt (1C).</p>
<p style="text-align: center;">1A ENROLL MODE</p>	<p>Enroll Mode This prompt can be used to confirm or enter a serial number. If "L" is displayed following "1A", the serial number for this transmitter has already been entered. It may, however, still be viewed, confirmed (only if in listen mode), or deleted. If "L" is not displayed following "1A", the serial number for this transmitter has not been previously entered. You may enter the serial number manually, copy the previous serial number, return to Prompt (E) or enter the serial number later using the *83 Enhanced Sequential Mode.</p> <p>Confirm serial number - The serial number/loop number combination can be confirmed after one transmission from a BR type device or two transmissions (fault and restore) from a UR or RF type device. If a transmission is received that matches the serial number and loop number entered, the system will confirm the reception by announcing the Voice Descriptor for the zone, (if programmed), followed by three beeps, and a "C" will appear on the display indicating the received serial number and loop number have been confirmed. No further transmissions will be received.</p> <p>Delete serial number - The serial number can be deleted by entering "9".</p> <p>Manual entry - Enter "1" to advance to Serial number prompt (1b).</p> <p>Copy the previous serial number - Enter "2" to copy the previous serial number entered.</p> <p>Return to Prompt (E) - Enter "#" to return to Loop Number prompt (E).</p> <p>Enter transmitter later - Enter "0" or "*" if you wish to enter the transmitter later, using the *83 Enhanced Sequential Mode described later in this manual.</p> <p>Notes: (1) Option 1 is not applicable if the serial number is already present. (2) If Option 2 is entered and this is the 1st zone, no serial will be in the buffer and the panel will emit a long beep. Not valid if serial number is already present. (3) Options 3 and 9 are only valid if "L" is displayed. If "L" is not displayed, panel will emit a long beep. (4) The panel will listen only when it is in the idle loop waiting for key entry and a serial number has been entered. If a key is entered, the function must be completed and the panel will listen again. (5) A long beep indicates illegal entry or duplicate serial number/loop entry.</p> <p>SELECTIONS 0 = advance to the VOICE DESCRIPTOR prompt (1C) and save all zone parameters. 1 = enter now and proceed to SERIAL NUMBER prompt (1b). 2 = copy the last serial number entered into local ram. 9 = advance to F; delete existing serial number. [*] = advance to the VOICE DESCRIPTOR prompt (1C). This will save all zone parameters. [#] = return to the LOOP NUMBER prompt (E).</p>

*56 Enhanced Zone Programming Mode

<p>1b SERIAL NUMBER</p>	<p>Serial Number This prompt can be used only to manually enroll a serial number. RF enrollment will be rejected and the current zone descriptor will be announced, followed by a single long beep and the system will return to prompt (1A). Enter the 7-digit serial number printed on the transmitter. If an incorrect digit is entered, press the [#] key to backup to prompt (1A) and start over. When all 7 digits are entered, press the [*] key. If 52 seconds passes and no entry has been made, the system returns to prompt (1A). Notes: (1) If the serial and loop number combination is already present the keypad will emit a single long beep and the system will return to the (1A) prompt and "L" will be displayed. (2) If less than 7 digits have been entered, the keypad will emit a single long beep and return to the (1A) prompt without displaying the "L". (3) If more than 7 digits have been entered, the first 6 digits will be saved along with the last digit that was entered (entering 123456789 yields the serial number 1234569). SELECTIONS Enter the transmitter's 7-digit serial number. [*] = return to prompt 1A, (if a valid serial number has been entered, the "L" is displayed and the serial number will be copied into EEROM from the last serial entered into the buffer.) [#] = return to prompt 1A and reject any serial numbers entries that have been made.</p>
<p>1c ZONE DESCRIPTOR</p>	<p>Voice Descriptor This prompt is used to select a voice descriptor. Each zone can have a voice descriptor of up to 3 words that will be announced whenever the system announces status for that zone. SELECTIONS 0 = skip to next zone (A) 1 = enter descriptor mode; existing descriptor for this zone will be announced</p>
<p>1d</p> <p>Note: System displays 2-digit selection & alpha descriptor OR 99 "No selection"</p>	<p>Descriptor 1 This prompt is used to enter a Voice Descriptor. Enter [#] + 2-digit vocabulary index number † of first descriptor word for this zone. Use the [6] or [8] key to advance to descriptor 2 or to next zone. To change the entered index number before pressing [6] or [8], simply press [#] + desired 2-digit vocabulary index number. If descriptor 1 is not desired, enter [#] + 99 (blank), then press [8] to return to zone number prompt. † see *84 Assign Zone Voice Descriptors section for vocabulary index SELECTIONS Enter [#] + 2-digit vocabulary index number † of first descriptor word for this zone. 6 = accept word and advance to descriptor 2 (descriptor 2 will be announced) 8 = accept word and advance to next zone (prompt A) – entire zone descriptor will be announced Press any other key to repeat the selected word</p>
<p>1e</p> <p>Note: System displays 2-digit selection & alpha descriptor OR 99 "No selection"</p>	<p>Descriptor 2 This prompt is used to enter a Voice Descriptor. Enter [#] + 2-digit vocabulary index number † of second descriptor word for this zone. Use the [6] or [8] key to advance to descriptor 2 or to next zone. To change the entered index number before pressing [6] or [8], simply press [#] + desired 2-digit vocabulary index number. If descriptor 2 is not desired, enter [#] + 99 (blank), then press [8] to return to zone number prompt. † see *84 Assign Zone Voice Descriptors section for vocabulary index SELECTIONS Enter [#] + 2-digit vocabulary index number † of first descriptor word for this zone. 6 = accept word and advance to descriptor 2 (descriptor 2 will be announced) 8 = accept word and advance to next zone (prompt A) – entire zone descriptor will be announced Press any other key to repeat the selected word</p>

*56 Enhanced Zone Programming Mode

<p><i>IF</i></p>	<p>Descriptor 3</p> <p>This prompt is used to enter a Voice Descriptor. Enter [#] + 2-digit vocabulary index number † of third descriptor word for this zone. Use the [6] or [8] key to advance to descriptor 2 or to next zone. To change the entered index number before pressing [6] or [8], simply press [#] + desired 2-digit vocabulary index number. If descriptor 2 is not desired, enter [#] + 99 (blank), then press [8] to return to zone number prompt. † see *84 <i>Assign Zone Voice Descriptors</i> section for vocabulary index</p> <p>SELECTIONS</p> <p>Enter [#] + 2-digit vocabulary index number † of first descriptor word for this zone. 6 = accept word and advance to descriptor 2 (descriptor 2 will be announced) 8 = accept word and advance to next zone (prompt A) – entire zone descriptor will be announced Press any other key to repeat the selected word</p>
------------------	--

Note: System displays 2-digit selection & alpha descriptor OR 99 “No selection”

***80 Device Programming Menu Mode**

Powerline Carrier Devices (e.g.; X10 brand devices) are programmable switches that can be used to perform many different functions, such as turning lights on and off, controlling sounders, or for status indications. In this system, each device must be programmed to perform a function (ACTION), when to activate (START), and when to deactivate (STOP). Each function is described below. Signals from the control panel are sent via the K10145X10 transformer or the PL513 Powerline Interface Module through the premises AC wiring to the Powerline Carrier Devices (which are plugged into AC outlets). Devices plugged into Powerline Carrier Devices can then be made to perform various functions in response to commands entered at the keypads in the security system. The control supports a total of 8 output devices. This mode is also used to program Remote Services Multi-mode (e-mail) event triggers.

UL Powerline Carrier Devices have not been evaluated by UL.

Programming Options Defined

The following will help you understand the programming of output devices when using *80 and *81 modes.

ACTION – The “ACTION” programming determines how the device will respond when it is activated by the “START” programming. There are four different choices of actions:

- ACTIVATE for 2 SECONDS and then reset.
- ACTIVATE and REMAIN ACTIVATED until stopped by some other event.
- PULSE ON and OFF until stopped by some other event.
- NOT USED when the device is not used.

START - The “START” programming determines when and under what conditions the device will be activated. The following “START” options are available:

Start by Event - An event is the condition (alarm, fault, trouble) that must occur to a zone or group of zones (zone list) in order to activate the device. These conditions apply **only** when a zone list is used. The different choices for “EVENT” are listed below and in the “Programming Powerline Carrier Devices” paragraph that follows.

- ALARM - Device activates upon any alarm in an assigned zone in the zone list.
- FAULT - Device activates upon any opening or short in an assigned zone in the zone list.
- TROUBLE - Device activates upon any trouble condition in an assigned zone in the zone list.
- NOT USED - Device action is not dependent upon one of the above events.

A zone list is a group of zones to which the “EVENT” applies in order to activate a particular device. There are a total of 3 output device-related zone lists that can be programmed in *81 menu mode. When the selected EVENT (alarm, fault or trouble) occurs in **any** zone in the selected “Start” ZONE LIST (1, 2, or 3), activation of the selected device will START.

Start by Zone Type or System Operation

If a system operation, such as “DISARMING” or “ANY FIRE ALARM,” is to activate the device, the appropriate choice would also be entered under the “ZONE TYPE” option. “ZONE TYPE” is used independently of the “EVENT/ZONE LIST” combination.

If a “ZONE TYPE” is chosen, any zone of that response type going into alarm, trouble, or fault will cause the device to activate as selected in “ACTION.” If the same “ZONE TYPE” is also chosen for the STOP programming, any zone of that type that restores will de-activate the device.

If a “SYSTEM OPERATION” is chosen (e.g., End of Exit Time), that operation will cause the device to activate as selected in “ACTION”. The different choices for “ZONE TYPE” and “SYSTEM OPERATION” are listed in the “Start zone type” paragraphs later in this section, and in the Programming Form.

STOP - The “STOP” programming determines when and under what conditions the device will be deactivated. The following options are available:

Upon Restore of a Zone List - Restore Zone List: If a “ZONE LIST” is used as the “Stop” event, the device will de-activate when **all** the zones in that list restore from a previous fault, trouble, or alarm condition. This will occur regardless of what is programmed to “START” the device; therefore, a “RESTORE ZONE LIST” would normally only be used when a “ZONE LIST” is used to start the device.

*80 Device Programming Menu Mode

Upon a Zone Type or System Operation - Zone Type/System Operation: Instead of using a “RESTORE ZONE LIST”, a specific zone (response) type or system operation action can be selected to de-activate the device.

If a specific “ZONE TYPE” is chosen, any zone of that response type that restores from a previous alarm, trouble, or fault condition will cause the device to de-activate.

If a “SYSTEM OPERATION” is chosen, that operation will cause the device to de-activate.

During normal system operation, any devices may be:

- Manually started by keypad entry of: **Code* + [#] + 4 + “nn;”** OR
- Manually stopped by keypad entry of: **Code* + [#] + 7 + “nn;”** where “nn” = the 2-digit device number to be controlled.

* Code is required for devices 07 and 08. For devices 01-06, code is not required. See User Manual for more information.

Programming Powerline Carrier Devices

While in Program mode, press *80 to enter Device Programming Menu Mode. This mode is used to program all output devices used in the system. Refer to the output device table for *80 on the separate programming form when programming output devices.

Note: The House ID of the Powerline Carrier Devices must be entered in data field *25.

The following explains these prompts in detail. The left two columns identify the prompts and list the available entries. The right-most column provides a further explanation of the entries.

Note: Entering a number other than one specified will give unpredictable results.

<p style="text-align: center;">80 DEVICE PROG MENU</p>	<p>Powerline Carrier Device Programming Entering “0” exits mode, upon which this prompt blinks, indicating that the mode is inactive. Entering “1” advances to the next prompt below.</p> <p>SELECTIONS 0 = exit mode 1 = enter mode</p>
<p style="text-align: center;">AD1 DEVICE NUMBER</p>	<p>Device Number Enter the 2-digit device number to be programmed.</p> <p>SELECTIONS 01-08 = X10 device number to be programmed 09-16 = Multi-mode (e-mail) event triggers [*] = continue 00 = exit Device Programming mode</p>
<p style="text-align: center;">b DEVICE ACTION</p>	<p>Device Action Enter the 1-digit device action (0-3) for the device being programmed (current action is displayed).</p> <p>Notes: (1) If “3” is entered (pulse), only up to 3 different devices can be pulsed if one of the devices is a siren/horn (X10 Powerhouse Security model SH10A). In addition, the siren/horn cannot be manually activated using the lights on/lights off keypad commands. (2) If using an X10 Powerhouse Security SH10A siren, you must use device action “3” and change the device action default to “3” (if using default table 2 or 4).</p> <p>SELECTIONS 0= No response 1 = Close for 2 seconds 2 = Close and Stay Closed 3 = Continuous Pulse on & off (1 sec ON, 1 sec OFF) [*] = continue [#] = return to previous prompt</p>

*80 Device Programming Menu Mode

<p>C START EVENT TYPE</p>	<p>Start Event Type Enter the 1-digit start event type (0-3) to activate the device being programmed. A zone list must be used in conjunction with an event. If a zone type/system operation is to be used instead of an event, enter "0".</p> <p>SELECTIONS 0 = Not used 1 = Alarm 2 = Fault 3 = Trouble [*] = continue [#] = return to previous prompt</p>																												
<p>d START ZONE LIST</p>	<p>Start Zone List If a zone list will be used to start the device action, enter the 1-digit zone list number for the device being programmed.</p> <p>SELECTIONS 1-3 = zone list number (to be programmed in field *81) 0 = zone list not used for this device [*] = continue [#] = return to previous prompt</p>																												
<p>E START ZONE TYPE</p>	<p>Start Zone Type If a zone type or system operation will be used to start the device action, enter the appropriate 2-digit code for the device being programmed (see table that follows).</p> <p style="text-align: center;">Choices for zone types</p> <table border="0"> <tr> <td>00 = Not Used</td> <td>07 = 24 Hr Audible</td> </tr> <tr> <td>01 = Entry/Exit #1</td> <td>08 = 24 Hr Aux</td> </tr> <tr> <td>02 = Entry/Exit #2</td> <td>09 = Fire without verification</td> </tr> <tr> <td>03 = Perimeter</td> <td>10 = Interior w/Delay</td> </tr> <tr> <td>04 = Interior Follower</td> <td>14 = Carbon Monoxide</td> </tr> <tr> <td>05 = Trouble Day/Alarm Night</td> <td>24 = Silent Burglary</td> </tr> <tr> <td>06 = 24 Hr Silent</td> <td></td> </tr> </table> <p style="text-align: center;">Choices for system operation</p> <table border="0"> <tr> <td>20 = Arming-Stay</td> <td>38 = Chime</td> </tr> <tr> <td>21 = Arming-Away</td> <td>52 = Kissoff</td> </tr> <tr> <td>22 = Disarm. (Code + OFF)</td> <td>39 = Any Fire Alarm</td> </tr> <tr> <td>31 = End of Exit Time</td> <td>40 = Bypassing</td> </tr> <tr> <td>32 = Start of Entry Time</td> <td>42 = System Battery Low</td> </tr> <tr> <td>33 = Any Alarm (except ZT 08, 09, 14 or 16)</td> <td>43 = Communications Failure</td> </tr> <tr> <td>36 = At Bell Timeout**</td> <td>58 = Duress</td> </tr> </table> <p>** Or at Disarming (which ever occurs earlier)</p> <p>SELECTIONS 01-58 = zone type to start this device action (select only those that are applicable) 00 = zone type not used for this device [*] = continue [#] = return to previous prompt</p>	00 = Not Used	07 = 24 Hr Audible	01 = Entry/Exit #1	08 = 24 Hr Aux	02 = Entry/Exit #2	09 = Fire without verification	03 = Perimeter	10 = Interior w/Delay	04 = Interior Follower	14 = Carbon Monoxide	05 = Trouble Day/Alarm Night	24 = Silent Burglary	06 = 24 Hr Silent		20 = Arming-Stay	38 = Chime	21 = Arming-Away	52 = Kissoff	22 = Disarm. (Code + OFF)	39 = Any Fire Alarm	31 = End of Exit Time	40 = Bypassing	32 = Start of Entry Time	42 = System Battery Low	33 = Any Alarm (except ZT 08, 09, 14 or 16)	43 = Communications Failure	36 = At Bell Timeout**	58 = Duress
00 = Not Used	07 = 24 Hr Audible																												
01 = Entry/Exit #1	08 = 24 Hr Aux																												
02 = Entry/Exit #2	09 = Fire without verification																												
03 = Perimeter	10 = Interior w/Delay																												
04 = Interior Follower	14 = Carbon Monoxide																												
05 = Trouble Day/Alarm Night	24 = Silent Burglary																												
06 = 24 Hr Silent																													
20 = Arming-Stay	38 = Chime																												
21 = Arming-Away	52 = Kissoff																												
22 = Disarm. (Code + OFF)	39 = Any Fire Alarm																												
31 = End of Exit Time	40 = Bypassing																												
32 = Start of Entry Time	42 = System Battery Low																												
33 = Any Alarm (except ZT 08, 09, 14 or 16)	43 = Communications Failure																												
36 = At Bell Timeout**	58 = Duress																												
<p>F STOP ZONE LIST</p>	<p>Stop Zone List If a zone list will be used to STOP, or restore, the device action, enter the zone list number 1, 2, or 3 (to be programmed in *81 mode). If not used, enter "0".</p> <p>SELECTIONS 1-3 = zone list to stop this device action 0 = zone list not used [*] = continue [#] = return to previous prompt</p>																												

*80 Device Programming Menu Mode

<p>1A STOP ZONE TYPE</p>	<p>Stop Zone Type If a zone type or system operation will be used to STOP the device action, enter the appropriate 2-digit code (see the "ZT" choices listed above). If not, enter 00. The display then returns to the DEVICE NUMBER prompt (A) so that you can enter the next device number to be programmed, or enter [0][0] to end device programming.</p> <p>SELECTIONS 01-58 = zone type to stop this device action (select only those that are applicable) 00 = zone type not used for this device [*] = continue [#] = return to previous prompt</p>
--	---

*81 Zone List Menu Mode

While in Program mode, press *81 to enter Zone List Menu Mode. This mode is used to program zone lists for output devices (programmed in *80 Device Programming Menu Mode) or Chime-by-Zone in Zone List 3. The following explains these prompts in detail. The left two columns identify the prompts and list the available entries. The right-most column provides a further explanation of the entries.

- Notes:**
- (1) Any list may include any or all of the systems zone numbers
 - (2) A zone list can be assigned to more than one Powerline Carrier Device
 - (3) Entering a number other than one specified will give unpredictable results.
 - (4) Do not assign zones with zone types 20, 21 or 22 to a zone list.

<p>81 ZONE LISTS MENU</p>	<p>Zone List Programming Entering "1" advances to the next prompt below. Entering "0" exits mode, upon which this prompt blinks, indicating the mode is inactive. SELECTIONS 0 = exit mode 1 = enter mode</p>
<p>A01 ZONE LIST NUMBER</p>	<p>Zone List Number Enter the Zone List Number 01, 02, or 03 to program (or 00 if no zone lists are used). Note: Use Zone List 3 for Chime by Zone feature. SELECTIONS 01-03 = zone list number to be programmed 00 = exit Zone List mode [*] = continue</p>
<p>b ZN ENTRY TO LIST</p>	<p>Zone entry to list Enter the 2-digit zone number for each zone number to add to the zone list by first entering the zone number, then the [*] key (for example, 01* 02* 03*). The system will announce the Voice Descriptor for the selected zone, if it is programmed. After all desired zones are enrolled, enter "00" to advance. SELECTIONS 01-41, 95, 96, 99 = zone numbers to add to zone list [*] = accept zone number and enter the next zone number 00 = accept zone number(s) and continue to next prompt</p>
<p>C DEL WHOLE ZN LST</p>	<p>Delete Entire Zone List Enter "1" to delete the zone list. All zones in the zone list will be deleted automatically and programming will return to the ZONE LIST NUMBER prompt. Enter "0" to save the zone list or delete specific zones from the list. SELECTIONS 0 = don't delete; continue to next prompt 1 = delete the current zone list</p>
<p>d DEL 1ZN FRM LST</p>	<p>Delete Zones from List? Enter "0" to save the entire zone list. Programming will return to the ZONE LIST NUMBER prompt. Enter "1" to delete a zone or zones in a zone list. SELECTIONS 1 = continue to delete zones prompt 0 = don't delete; continue to next zone list number prompt (A01) [#] = return to zone list number prompt (A01)</p>
<p>E DELETE ZONES</p>	<p>Delete Zones Enter each 2-digit zone number to be deleted from the current zone list, followed by the [*] key. When deleting a zone(s) from the zone list, if the selected zone has a Voice Descriptor programmed, upon deletion it will be announced as a confirmation that it has been deleted. After all zones to be deleted are entered, enter "00" to return to the ZONE LIST NUMBER prompt so that another list can be programmed, if desired. SELECTIONS [*] = delete zone and enter next zone to be deleted 00 = delete zone and return to next zone list number prompt (A01) desired)</p>

*83 Enhanced Sequential Mode

By using this mode, you can add, delete, or change the serial number of a transmitter in a zone, but retain all other existing data that has been programmed for that zone. Note that the *83 Enhanced Sequential mode requires that all zone information must first be entered using the *56 Enhanced Zone Programming mode for all zones below zone number 26 (4 button key area).

Certain button-type transmitters have more than one button (e.g., 5804). Note that each button must be assigned to a different zone. Similarly, the 5816 Transmitter has contact terminals and a reed switch for use with a magnet. If using both, each must also be assigned to a different zone.

This means that the procedures that follow must be repeated for each button-type zone below zone number 26 or contact on the transmitter. Four zone button-type devices are held in zones 26 and above. They will be started on boundaries of zones 26, 30, 34, and 38. These four zone button-type devices will have the option to have all information entered in this field. One entry will set the loop number, report code, zone type, and input device type for all 4 buttons, and a second entry will enter one serial number into four zones.

The following explains these prompts in detail. The left column identifies the prompts and lists the available entries. The right column provides a further explanation of the entries.

- Notes:**
- (1) Use this mode only after all other zone information has been programmed, including transmitter loop numbers except for button-type zones over zone number 26. The panel will stop at zones 26, 30, 34 and 38 and zone data can be entered as a default here
 - (2) Any zone which already has a serial number learned in will not be accessible in *83 Enhanced Sequential mode.
 - (3) Entry of a number other than one specified will give unpredictable results.
 - (4) In Enhanced Sequential Mode, 4 button type keys will always be enrolled simultaneously. They will be stopped at the 4 button boundaries of 26, 30, 34 and 38, provided the zone is free of a serial number. If the first zone of the key has a serial number enrolled, the remaining keys cannot be programmed in sequential mode. In addition, if the zone has not been set up (duplicate loop, missing zone type, etc.) only entries 0 (skip to the next zone) and 4 (copy the key template) will be allowed.
 - (5) You may find it convenient to adjust the volume setting before entering the Programming Mode. This will allow you to clearly hear feedback announcements or system beeps.

<p>R02 ZONE NUMBER</p>	<p>Zone Number Enter the 2-digit zone number of the first transmitter to have its serial number entered. The system will announce the Voice Descriptor for the selected zone number, if it is programmed. Press [*] to continue. Starting with this zone number, the system will search for the first transmitter that has all of the following attributes pre-programmed in *56 ENHANCED ZONE PROGRAMMING:</p> <ol style="list-style-type: none"> a) The appropriate input type was selected in *56 (RF, UR, or BR programmed) b) The appropriate loop number was selected in *56. c) No serial number has been programmed d) Zone type <p>If the first zone number entered does not have one or more of the above attributes, the system will search its database for the first zone that does, and will display it at the enroll SERIAL NUMBER prompt (1b). Enter 00 to exit. Prompt "83" blinks, indicating the mode is inactive.</p> <p>Note: Two exceptions to the requirement above exist for keys. Four zone button type devices (zone numbers 26, 30, 34, and 38) will be stopped only if there are no serial numbers enrolled in all 4 zones of the key, regardless of the attributes that have been entered. In addition, zone types are not required to be present. In this case, 1A, Option 4 must be selected prior to "Learn".</p> <p>SELECTIONS Enter 2-digit zone number. [*] = continue; system searches for zones not yet entered (for zones 2 through 25 a zone type must be entered), then advances to ENROLL SERIAL NUMBER prompt "1b" 00 = exit Sequential mode</p>
--	---

*83 Enhanced Sequential Mode

1A ENROLL MODE

Enroll Mode

This prompt is used to enter, view or confirm a serial number. If "L" is displayed, the serial number for this transmitter has already been entered; however, it may still be confirmed, viewed or deleted.

Enter serial number - If the transmitter's serial number has not been previously entered, you may enter the enroll serial number mode (1A) by entering "1".

Copy serial number - Enter "2" to copy the last serial number that was entered. A serial number must be entered in order to be copied. If no serial is stored in the buffer and a copy is attempted the panel will emit a long beep indicating an invalid operation.

View serial number - If the transmitter's serial number has been previously entered, you may, view the present serial number by entering "3". If view is selected each digit will be re-displayed, and the keypad will beep once for digits 1-6, and three times for the last digit. Once the serial number has been entered by either selecting a "1" or a "2", you will return to this prompt with the "L" on the display. The serial number/loop number combination that was entered can be confirmed by getting two transmissions (fault and restore) from the RF or UR device or one transmission from the BR device. If a transmission is received that matches the serial number and loop number entered, the system will announce the Voice Descriptor for the loop followed by three beeps, and a "C" will be displayed indicating that the received serial number and loop number transmission has been confirmed to match. No further transmissions will be received. When confirming a 4 button key, only the serial number is confirmed, since it assumed that all loops are used. Pressing any key will allow a confirmation.

Long beep indicates illegal entries, or duplicate serial number/loop entry

When the last zone has been entered, the display will remain on that zone. To exit this mode and return to data field program mode, enter 00 at the ZONE NUMBER prompt.

When all zones have been programmed, test each zone using the system's Test mode. Do not use the Transmitter ID Sniffer mode for this, since it will only check for transmission of one zone on a particular transmitter, and not the zones assigned to each additional loop.

For Zones 26-29, 30-33, 34-37, and 38-41 any loop can be used for RF enrollment. If enrolling via RF, it will be confirmed without additional transmissions.

Notes:

- (1) A valid template or key has 4 existing zones, each with a zone type, unique loop number.
- (2) Option 2 is not applicable for 4 button key zones 26-29, 30-33, 34-37, & 38-41.
- (3) If the display automatically returns to "1A" rather than "1b" the configuration of the key is not valid. At that point copy template, skip, or return are the only legal entries.
- (4) If option 3 or 9 is selected, the serial number can be viewed or deleted but only if "L" is displayed. If the "L" is not displayed the panel will emit a long beep.
- (5) If option 4 is selected template acceptance is indicated by two beeps after copying. A single long beep, emitted when copying indicates the template is not valid.

SELECTIONS

0 = advance to next zone to be enrolled

1 = enter now and proceed to SERIAL NUMBER prompt (1b). For 4 button keys (zones 26-29, 30-33, 34-37, & 38-41) the serial number will be enrolled to all four buttons. If enrolling a key, the panel will emit a long beep when entering a 1 to indicate that the present key set up is invalid.

2 = copy the previous serial number entry from the buffer.

3 = view existing serial number.

4 = copy the 4 button key template that has been set in zone numbers 26-29 (all zone parameters except serial numbers). (Only valid on zones 30-33, 34-37, & 38-41 that do not have serial numbers enrolled.)

9 = delete existing serial. Go to the (1A) prompt. For 4-button key, zones 26-29, 30-33, 34-37, & 38-41 have serial numbers. Delete all four at one time.

[*] = advance to next zone to be enrolled

[#] = return to previous prompt (A)

*83 Enhanced Sequential Mode

<p style="text-align: center;">1b SERIAL NUMBER</p>	<p>Serial Number This prompt can be used to enroll the transmitter serial number via RF transmission or manually. If using the RF Learning Mode there is no need to manually enter a serial number. Proceed directly to RF Learning. Upon entering the Serial Number mode, the Zone Descriptors will be announced. Note: BR type devices can be enrolled only by transmission from BR devices. Likewise, UR and RF devices can only be enrolled by transmission from a UR or RF device</p> <p>RF Learning Two (2) transmissions (2 key depressions) at least five seconds apart, will be required for BR type or four (4) transmissions (fault, restore and fault, restore) for UR or RF type. If the learned serial number has a different loop number than that entered in *56 the system will announce the Voice Descriptor, if it is programmed, followed by two beeps and will return to Prompt (1A) and “L” will be displayed. If the loop number captured by RF transmission and that entered in *56 mode match, the system will announce the Voice Descriptor, if it is programmed, followed by three beeps and return to Prompt (1A) and “LC” will be displayed. No additional transmissions are needed for confirmation.</p> <p>Manual Entry Enter the 7-digit serial number printed on the transmitter. If you enter an incorrect digit, press the [#] key to backup to prompt (1A) and start over. When all 7 digits are entered, press the [*] key. If less than 7 digits are entered, the keypad will emit a single long beep and return to the (1A) prompt without displaying the “L”. If more than 7 digits have been entered, the first 6 digits will be saved along with the last digit that was entered (entering 123456789 yields the serial number 1234569). Note: The system will return to prompt (1A) if an entry is not made within 52 seconds.</p> <p>SELECTIONS Enter transmitter’s 7- digit serial number via RF learning or manually. [#] = return to (1A) prompt and reject whatever serial number entries have been made. [*] = return to (1A) prompt (if a valid serial number has been enrolled, “L” is displayed and the serial number will be copied into EEROM and the last serial entered buffer. Note: For zones 26, 30, 34 and 38 only BR type devices can be used.</p>
<p style="text-align: center;">F DELETE ZONE CONF</p>	<p>Delete Serial Number This function deletes only the serial number. Entering a “9” at prompt (1A). Confirmation of the delete request will cause deletion of the serial number pertaining to the zone being programmed. Note: Entering a “9” at prompt (1A) will cause the panel to return to prompt (1A) regardless of the confirmation answer.</p> <p>SELECTIONS 0 = discard the delete request 1 = confirm requested delete</p>

Note: In Enhanced Sequential Learn Mode, 4 button type keys will always be learned simultaneously. They will be stopped at the 4 button boundaries of 26, 30, 34 and 38, provided the zone is free of a serial number. If the first zone of the key has a serial number learned, the remaining keys cannot be programmed in sequential learn mode. In addition, if the zone has not been set up (duplicate loop, missing zone type, etc.) only entries 0 (skip to the next zone) and 4 (copy the key template) will be allowed.

*84 Assign Zone Voice Descriptors

Use this mode to assign voice descriptors for each zone. These are the descriptors that are announced when the system announces any event involving a zone number. Each descriptor can consist of up to 3 words. To access this mode, Enter *84 while in Programming mode. The following explains these prompts in detail. The left column identifies the prompts and lists the available entries. The right column provides a further explanation of the entries.

Note: Entering a number other than the one specified will give unpredictable results.

<p>84 ZONE VOICE DESC</p>	<p>Assign Zone Voice Descriptors Entering "1" advances to the next prompt below. Entering "0" exits mode, upon which prompt "84" blinks, indicating the mode is inactive.</p> <p>SELECTIONS 0 = exit mode 1 = enter mode</p>
<p>A ZONE NUMBER</p>	<p>Zone Number Enter the 2-digit zone number for which this descriptor is being assigned, then press [*]. The Voice Descriptor for the selected zone will be announced, if it is programmed.</p> <p>SELECTIONS [*] = continue to next prompt (any existing descriptors will be announced, then descriptor 1 will be repeated) 00 = exit voice descriptor mode</p>
<p>b DESCRIPTOR1</p>	<p>Descriptor 1 Enter the first word of the descriptor for the selected zone. Use the [6] or [8] key to advance as described. To change the entered index number before pressing [6] or [8], simply press [#] + desired 2-digit vocabulary index number. If descriptor 1 is not desired, enter [#] + 99 (blank), then press [8] to return to zone number prompt.</p> <p>SELECTIONS Enter [#] + 2-digit vocabulary index number of first descriptor word for this zone. 6 = accept word and advance to descriptor 2 (descriptor 2 will be announced) 8 = accept word and advance to prompt (A) for next zone. Press any other key to repeat the selected word.</p>
<p>C DESCRIPTOR2</p>	<p>Descriptor 2 Enter the second word of the descriptor for the selected zone. Use the [6] or [8] key to advance as described. To change the entered index number before pressing [6] or [8], simply press [#] + desired 2-digit vocabulary index number. If descriptor 1 is not desired, enter [#] + 99 (blank), then press [8] to return to zone number prompt.</p> <p>SELECTIONS Enter [#] + 2-digit vocabulary index number of second descriptor word for this zone. 6 = accept word and advance to descriptor 3 (descriptor 3 will be announced) 8 = accept word and advance to prompt (A) for next zone. Press any other key to repeat the selected word.</p>
<p>d DESCRIPTOR3</p>	<p>Descriptor 3 Enter the last word of the descriptor for the selected zone. Use the [6] or [8] key to advance as described. To change the entered index number before pressing [6] or [8], simply press [#] + desired 2-digit vocabulary index number. If descriptor 3 is not desired, enter [#] + 99 (blank), then press [8] to return to zone number prompt.</p> <p>SELECTIONS Enter [#] + 2-digit vocabulary index number of third descriptor word for this zone. 6 or 8 = accept word and advance to prompt (A) for next zone. Zone descriptor will be announced. Press any other key to repeat the selected word.</p>

*84 Assign Zone Voice Descriptor

VOICE VOCABULARY INDEX

00 ½ second pause	G	P	Z	SYSTEM WORDS
A	48 GARAGE	61 PATIO	81 ZERO	AC LOSS
82 ALARM	49 GUEST ROOM	62 POLICE	86 ZONES	ARMED
32 ATTIC	09 GUN	18 POOL		AWAY
B	H	R	29 1st	BYPASSED
01 BABY	50 HALL	63 REAR	30 2nd	CARBON MONOXIDE
33 BACK	I	19 ROOM	31 3rd	CHIME
34 BASEMENT	10 INSIDE	S	70 Custom Word #1	DISARMED
35 BATHROOM	K	64 SECOND FLOOR	71 Custom Word #2	DISARM SYSTEM
36 BEDROOM	51 KITCHEN	65 SEVEN	72 Custom Word #3	NOW
C	L	20 SHED	73 Custom Word #4	EXIT NOW
83 CHECK	11 LAUNDRY	21 SHOP	74 Custom Word #5	FAULT
D	52 LAUNDRY ROOM	66 SIDE		INSTANT
37 DELAY DOOR	12 LIBRARY	67 SILENT POLICE	99 Blank	LOW BATTERY
38 DEN	13 LIVING	68 SIX	(for erasing a previously	NOT
02 DETECTOR	53 LIVING ROOM	69 SLIDING	programmed word)	READY TO ARM
03 DINING	M	22 SMOKE		STAY
39 DINING ROOM	14 MAIN	23 SOUTH		
04 DOOR	15 MASTER	24 STORAGE		
40 DOWNSTAIRS	54 MASTER	25 THIRD FLOOR		
05 DRIVEWAY	BEDROOM	75 THREE		
E	55 MEDICAL	76 TRANSMITTER		
06 EAST	84 MESSAGE	77 TWO		
41 EIGHT	56 MOTION	U		
42 EMERGENCY	DETECTOR	78 UPSTAIRS		
F	N	26 UTILITY		
43 FAMILY ROOM	57 NINE	79 UTILITY ROOM		
87 FIRE	16 NORTH	W		
44 FIRE DETECTION	58 NURSERY	27 WEST		
07 FIRST FLOOR	O	80 WINDOW		
45 FIVE	59 OFFICE	Y		
08 FLOOR	60 ONE	28 YARD		
46 FOUR	17 OUTSIDE			
47 FRONT				

Notes: (1) If button type device is used to Arm Away, Arm Stay, and disarm the system it is recommended to assign "Check" and "Zones" voice descriptors to each of the three zones. This will allow the system to announce "Check Zones" "Low Battery" if the button device has a low battery.

(2) If a Wireless Keypad is being installed along with this system, not all the voice descriptors shown on this list can be announced by keypad. (Refer to the Wireless Keypad documentation for further information).

*85 Record Custom Voice Descriptors

Use this mode to record up to 5 custom voice descriptors. To enter this mode, enter *85 while in Programming mode.

Note: Entering a number other than one specified will give unpredictable results.

<p>85 REC VOICE DESC</p>	<p>Assign Custom Voice Descriptors Entering "1" advances to the next prompt below. Entering "0" exits mode, upon which "85" prompt blinks, indicating the mode is inactive.</p> <p>SELECTIONS 0 = exit mode 1 = enter mode</p>
<p>A CUSTOM DESC #</p>	<p>Custom Descriptor Number Record up to 5 custom words. Enter 7 + d + [*]</p> <p>Note: d = 0-4, each representing custom word 70, 71, 72, 73, or 74, respectively. Any existing word will be announced</p> <p>Press [#] to start recorder. Begin speaking immediately after the third beep. Speak the desired word clearly near the microphone. Recording stops after 1.5 seconds.</p> <p>SELECTIONS 0 = exit mode 1 = enter mode 6 = accept word and ready to record next descriptor prompt (A...7d) [#] = re-record descriptor 00 = exit Record mode after pressing 6 to accept word Press any key to repeat the recorded word.</p>

Remote Programming/Control (Downloading)

General Information

The control panel can be remotely programmed from an IBM-compatible Personal Computer (PC), Compass Downloader, a HAYES Modem or via a capable GSM or IP communications device.

UL Downloading may only be performed if a technician is at the site.

Multiple security levels protect remote programming against compromise by attempts to defeat the system.

- 1. Security Code Handshake:** An 8-digit download ID code must be matched between the Control and downloader.
- 2. Site-Initiated Remote Programming:** The installer or subscriber initiates the call from the subscriber premises by entering the Installer Code + # + 1, while the system is disarmed. All parameters can then be downloaded via the phone lines using a personal computer.
- 3. Station-Initiated Remote Programming:** The operator calls the site from your office to initiate the download call. The Control hangs up and then calls back the PC via the preprogrammed telephone number. The unit can then be uploaded, downloaded, or controlled from your office.
- 4. Telco Handoff:** The installer or subscriber performs a download session on the call initiated from the site or from local laptop computer by entering the Installer or Master Code + # + 1 at the control panel.
- 5. Data Encryption:** Data passed between the PC and the Control is encrypted for security so that it is very difficult for a foreign device tapped into the phone line to take over communication and substitute system-compromising information.

Equipment required to download to a system at the premises

- An IBM PC compatible computer and appropriate interconnecting cables.
- *Either* a HAYES brand SMARTMODEM 1200 (Level 1.2 or higher external or Level 1.1 or higher [with 4 position DIP switch] internal style), a HAYES brand Optima 336 external, a HAYES brand Optima 24 Plus FAX96, or an Ademco CIA Modem or via a capable GSM or IP communications device.
- Compass Downloader for Windows (at revision level supporting ReadyGuard Plus).

Initial Download: Enter Installer Code + # + 5. This sets field *95 to 4 rings, and system to “no call-back” option. The download computer can then call the subscriber, make connection, and download all programming data.

Flexible Callback: If enabled in field *93, the download operator can temporarily change the last 1, 2, or 3 digits (depending on selection) of the call back number. This allows the control to call back a computer other than the one programmed, which may be helpful at times of high computer traffic. Refer to 93 Flexible Callback programming field for additional information.

Remote Programming Information



If using Remote Programming, the ReadyGuard Plus must be connected to the telephone line or to the Internet, as applicable.

The downloading system can perform many functions when in communication with the Control. Besides uploading and downloading, the status of the system can be observed and various commands can be initiated, as follows:

- Arm the system in the away mode; disarm the system.
- Bypass a zone.
- Force the system to accept a new program download.
- Shut down communication functions (for nonpayment of monitoring fees in an owned system).
- Shut down all security system functions (for nonpayment for a leased system).
- Inhibit local keypad programming (prevents account takeover).
- Command the system to upload a copy of its resident program to the office.
- Set the time
- View/Modify
- X10/ Scheduling

Remote Programming/Control (Downloading)

- Read: arming status, AC power status, lists of faulted zones, bypassed zones, zones currently in alarm, zones currently in trouble, and RF sensors with low battery conditions; read control's time.

Notes: (1) After the control and the PC have established valid communication, the keypad will become inactive and will display "**CC Modem Comm.**"

(2) The keypad will become active after the download communication is terminated.

(3) The detailed operation of the download functions is covered in the installation instructions for the Compass Downloader for Windows.

Remote Programming Advisory Notes

- Keypad entries are ignored during the time interval stated above.
- A copy of the program downloaded may be printed using the IBM PC-compatible computer's internal report generator, when an optional printer is connected (consult your PC manual for proper printer and connections).
- Program upload or download time is approximately one minute, fifteen seconds for a complete program.

System Operation

Keypad Operation

The keypad allows the user to arm and disarm the system, and perform other system functions, such as bypassing zones. Zone and system conditions (ALARM, trouble, bypass) are displayed on the keypad. When an alarm occurs, keypad sounding and external sounding will occur, and the zone(s) in alarm will be displayed on the keypad. Pressing any key will silence the keypad sounder for 10 seconds (only once). Disarming the system will silence both keypad and external sounders. When the system is disarmed, any zones that were in an alarm condition during the armed period will be displayed (memory of alarm). To clear this display, simply repeat the disarm sequence by entering the Security Code and pressing the OFF key. The keypad also features chime annunciation, and 3 panic key pairs for silent, audible, fire or personal emergency alarms. These keys can notify the central station of an alarm condition, if that service is connected.

Panic Keys

There are three panic key pairs that, if programmed, can be used to manually initiate alarms and send a report to the central station. Each can be individually programmed for 24-hour silent, audible, personal or fire emergency responses. The panic function is activated when both keys of the appropriate key pair are pressed at the same time. The panic functions are identified by the system as follows:

Keys	Displayed as Zone
[1] & [*]	95
[*] & [#]	99
[3] & [#]	96

Important: For the silent panic functions to be of practical value, the system must be connected to a central station.

Security Codes

Installer Code

The installer programs the 4-digit Installer Code initially as part of the programming procedure. The factory default Installer Code is **4-1-1-2**, but may be changed in field *20. The Installer Code is the only code that allows entry into Programming mode and also, in normal operation mode, is used to enter the Master Code, which allows access to the normal functions of the system.

Master Code

In normal operation mode, the Installer Code is used to enter the 4-digit Master Security Code.

Enter/change the Master code by installer.

At the keypad enter: Installer Code + [CODE key] + [02] + desired 4-digit Master Code

Change the Master code by master user.

At the keypad enter: Current Master Code + [CODE key] + [02] + new Master Code + new Master Code again

Secondary User Codes

In normal operation mode, the Master Security Code can be used to assign up to 6 secondary 4-digit security codes, including a Babysitter Code and a Duress Code. The Master Code can also be used to remove secondary codes from the system (individually).

Assign (or change) a secondary security code.

At the keypad enter: Master Code + [CODE key] + User # (03–08) + desired Secondary Code
The system will emit a single beep when each secondary code has been successfully entered.

Delete a secondary security code.

At the keypad enter: Master Code + [CODE key] + User # (03–08)

System Operation

Security Code Notes

- The Master and Secondary security codes permit access to the system for arming, disarming, etc.
- The Installer Code can disarm the system only if it was used to arm it. In addition, the Installer Code cannot disarm the system if it was armed by pressing and holding a Quick-Arm button.
- The Babysitter Code (User Code No. 7) can disarm the system only if it was used to arm it. In addition, the Babysitter Code cannot disarm the system if it was armed by pressing and holding a Quick-Arm button.
- Duress code (User Code No. 8) sends a special code to the monitoring station when used to perform any system operation. Instruct users to be careful not to use this code for normal usage. If the duress code is programmed, you must enter a report code for Zone 92 (duress).
- If a secondary code is inadvertently repeated for different users, the lower user number will take priority.
- Opening/closing reports are sent for the Installer Code as No. 01, with the appropriate subscriber number. Master Code and set of secondary user codes are sent as Nos. 02 and 03–08, respectively, in Contact ID® format (with the appropriate user number); in 4 + 2, it is 1–8. Quick arming (and open/close executed by downloader) is reported as user 00.

“Follow Me” Reminder Feature

This feature allows the user to schedule a time driven message. When activated, the system will dial a phone number that the installer programs in Field *46, and deliver a voice message (custom words 72, 73, and 74). The ReadyGuard Plus will immediately begin transmitting the voice message and will repeat the message for 45 seconds. Pressing any touch-tone key on the answering phone will acknowledge the message ending the session and preventing the system from redialing the programmed number. Delivery of a reminder message on the local ReadyGuard Plus keypad will continue. If the message has timed out the system will redial the programmed number a maximum of seven additional times or until it is acknowledged. Pressing any key on the ReadyGuard Plus keypad will terminate (acknowledge) both the follow me reminder and the local reminder announcements.

- Notes:**
- (1) This feature is only supported if programmed in field *49.
 - (2) The follow me reminder will be terminated if any other event requires the system to dial out, or if an audible alarm has occurred, however, delivery of the local schedule reminder message will continue.

“Follow Me” System Announcement Feature

This feature allows the ReadyGuard Plus to deliver a voice system message to the secondary phone number programmed by the installer. The ReadyGuard Plus will first transmit reports to the Central Station and after receiving its kiss-off the system will dial the secondary phone number and begin transmitting the voice message. This message is a repeatable system status announcement. Like the Follow Me reminder, pressing any key on the answering telephone or the local ReadyGuard Plus keypad will terminate (acknowledge) the message. The system will dial the secondary phone number a maximum of eight times. The Follow Me alarm functions may be triggered by a variety of events depending upon the selections made during programming in field *49.

Note: The follow me system announcement will be terminated if any other event requires the system to dial out or if an audible alarm has occurred.

Remote Phone Control Feature

The remote phone control feature, which must be enabled in field *91, allows the user to access the security system from any off-site touch-tone telephone. The control will pick up the incoming call, based on the ring count specified in field *95, and will announce “SYSTEM ENTER CODE” every three (3) seconds for the next eight (8) seconds. During this period the panel will wait for a valid User Code to be entered. If a valid User Code is not entered or the eight (8) second period expires a modem tone will be generated for remote programming (Compass Downloading). If a valid User Code has been entered, the control will announce the current system status and/or beeping sounds. Refer to the User Guide for additional information regarding this feature.

System Operation

Exit Error Alarm Displays

The system will display the following if programmed in Field *59. Entering a second Code + OFF sequence will clear the display.

Display	Meaning
CA Alarm Cancelled	Appears along with a zone indication if an exit or interior zone contained a fault during closing at the time the exit delay ended (e.g., exit door left open), but the system was disarmed during the entry delay time. The alarm sounder and keypad sound continuously, but stop when the system is disarmed. No message will be transmitted to the central station.
EA Exit Error	Appears along with a zone indication if an exit or interior zone contained a fault during closing when the exit delay ended, but the system was NOT disarmed during the entry delay time. The alarm sounder and keypad sound continuously until the system is disarmed (or timeout occurs). An Exit Alarm message is sent to the central station. OR if an alarm from an exit or interior zone occurs within two minutes after the end of an exit delay

System Displays

Display	Meaning
PC Remote Phone	Remote Phone Control feature is active (Appears in place of the clock).
PH Speakerphone	System Speaker Phone mode is active (Appears in place of the clock).
EE Invalid Entry	Displayed when an invalid entry is made.
Phn Follow Me Phone#	Displayed when programming a Follow Me Phone Number.
EE Invalid Entry	Data entry error (invalid field number entered while programming. Re-enter a valid field number).

System Trouble Displays

Display	Meaning
CC Modem Comm	Appears when the system is communicating with the central station for change of function or status verification.
d1 StandBy	Displayed approximately 4 seconds after power-up. After approximately 1 minute* the green "READY" LED should light and the real-time clock will appear. If the "d1" remains displayed for more than 1 minute, the system is disabled. *To bypass the 1-minute delay, press [#] + [0]. Important: Do not try to bypass 1minute delay before "d1" is displayed!
FC Comm Fail	Appears when a communication failure has occurred. This message clears only when the system is subsequently armed.
90 RF Jam	Appears when the system has detected an RF jamming condition or excessive interference.
00 RF Keypad	Indicates a problem with an RF keypad (i.e.; keypad low battery).
No display	If there is no keypad display at all, and the LED indicators are not lit, operating power for the system has stopped and the system is inoperative. If the display is lit and the AC display is off, the system is operating on battery power only. During an AC power loss, the backlighting will turn off and the indicators will flicker slightly to minimize deep discharge of the battery.

System Operation

The following words or phrases define conditions on specific zones or individually displayed system status conditions.

Display	Meaning
Fault	A malfunction is discovered in the system; or an open is detected in a fire zone; or a fault in a day/night burglary zone is discovered during a disarmed period. Accompanied by a display of the zone number in trouble. The fault condition may also be caused by some change in the environment that prevents the built-in receiver from receiving signals from a particular wireless sensor. After correcting the problem, the display can be cleared by entering the security code plus the OFF key twice.
Fault 103	Indicates one of the following: <ul style="list-style-type: none"> • control panel lost communication with the communications module • communications module tamper detected (cover removed) • primary communications path failure • radio is not registered; account not activated • primary power loss • secondary communications path failure • battery charger failure • low battery
ALARM	System is armed and an intrusion has been detected (also appears during a Fire Alarm or audible emergency alarm). Accompanied by the protection zone that is in alarm.
FIRE	A Fire Alarm or Fire Fault is present. Accompanied by a display of the zone that is in alarm
CO	Displayed when a Carbon Monoxide Alarm or Fault is present.
No AC	AC power is not present. If displayed, the system is operating on backup battery power.
Stay	Perimeter Burglary zones, such as protected windows and doors, are armed
Away	All burglary zones, interior and perimeter, are armed.
StayInst or AwayInst	Entry delay is turned off.
Bypass	One or more burglary protection zones have been bypassed.
Chime	Chime feature is active (displayed only when the system is disarmed)
Lowbat	Displayed with no zone number indicates that the system's backup battery is weak. Displayed with a zone number and a once-per-45 seconds "beeping" at the keypad indicates that a low battery condition exists in the wireless sensor displayed (zone "00" indicates a wireless button/keypad). If the battery is not replaced within 30 days, a "FAULT" display may occur.
Msg	A message has been recorded and has not yet been played back.
Rec	The system is in Recording mode.
Test in Progress	System is in Test mode.
Ready or NotReady	System status displayed only when the system is disarmed
Exit Now	System has been armed and the exit delay is active
bF	Indicates Communications Module failure (displayed on RF Keypad only)

System Operation

UL Audio alarm verification has not been evaluated by UL.

Audio Alarm Verification (Two-Way Voice Feature)

This feature allows the central station operator to listen, talk to or conduct a two-way conversation with an individual(s) at the premises. It also assists the operator in gathering information about the nature and location of the alarm that may be helpful in responding to police and fire departments. All ReadyGuard Plus control panels are capable of supporting the Two-Way Voice feature. The ReadyGuard Plus does not make system announcements when the Two-Way voice feature is active.

Activation



Fire and CO alarms will not trigger an AAV session. A new Fire or CO alarm will end an AAV session that is in progress.

The ReadyGuard Plus sends the “alarm message” followed by a “Listen-in-to-Follow message” (Contact ID® code 606) to the Central Station. The Listen-in-to-Follow message causes the Central Station’s digital receiver to temporarily hold the phone line for approximately 1-minute. When the ReadyGuard Plus receives the “kissoff” from the central station, indicating that the alarm message has been received, the Two-Way Voice (AAV) feature is activated in the (default) “Listen Mode” and sirens and keypad sounds are discontinued. The ReadyGuard Plus transmits a beep acknowledgment to the Central Station, once per second. The beep alternates between two tones and indicates that the ReadyGuard Plus is waiting for a session command from the Central Station operator. Once a command is issued the beep acknowledgement is discontinued, however, if a command is not issued within two minutes the system will “time out” and the call will be terminated.

Operator Commands

The Central Station operator begins the session, which last 5 minutes, by entering one of the valid AAV commands shown in the table below. The session may be extended 5 minutes, without changing the operating mode, by pressing the [7] key on the touch-tone phone. Selecting another operating mode also resets the session an additional 5 minutes. During the last minute of the 5 minute, session, the ReadyGuard Plus generates two beeps every 30 seconds to alert the Central Station operator that the session is about to time out. The Central Station operator may then extend the session by pressing the [7] key on the touch-tone phone. If the session is not extended the phone line is disconnected, and the session is ended. Sessions may be ended at any time by pressing the [9] key on the touch-tone phone. The AAV modes are described as follows:

Note: When entering AAV commands make sure the Central Station receiver has been disconnected from the phone line, otherwise AAV commands may not go through.

Key	Function
1	Talk Mode: Pressing the [1] key on the touch tone phone, enables one-way voice communication from the central station to the violated premises, and allows the operator to talk communicate through the ReadyGuard Plus speaker. In this mode the ARMED (red) and READY (green) LEDs blink alternately.
2	VOX (Voice) Mode: Pressing the [2] key on the touch-tone phone, enables two-way voice communications between the central station and the violated premises. In this mode the ARMED (red) and READY (green) LEDs blink alternately.
3	Listen Mode: Pressing the [3] key on the touch-tone phone, enables one-way audio from the violated premises to the central station. The Listen Mode is the start up default mode of the voice feature and allows the operator to listen through the ReadyGuard Plus microphone. This mode does not affect the existing LED pattern.
7	Extends the session 5 minutes without changing its operating mode.
9	Ends the session and disconnects the phone line.

Testing the System

Test Mode

After installation is completed, the security system should be carefully tested, as follows.

1. With the system in the disarmed state, check that all zones are intact. If the **READY** LED is not lit, press the [*] key to display the faulted zone(s). Restore faulted zone(s), if necessary, so that the **READY** LED lights. Fault and restore every sensor individually to assure that it is being monitored by the system.
2. Enter the **security code** and press the **TEST** key. The outside sounder will sound for 1 second. "Test in Progress" will subsequently be displayed on the keypad. The control announces the zone's voice descriptor (if programmed) followed by 3 beeps, each time a contact is faulted. A test report should be transmitted (if programmed) to the central station immediately. If the backup battery is discharged or missing, the sounder may not turn on and a **LOW BATTERY** report will be transmitted with a **TEST** report. The keypad will beep once every 45 seconds as a reminder that the system is in the Test mode.
3. To turn off the Test mode enter **security code** and press the **OFF** key.

Notes: (1) Triggering a zone set to Arm AWAY, Arm STAY, or Disarm will take the system out of Test and cause that action.
(2) BR type transmitters do not display during Test mode (keypad beeps only)
(3) Macros cannot be run from the Test mode.
(4) Test mode automatically ends after 4 hours.

Armed System Test

Alarm messages will be sent to the central station during the following tests 1 and 2. Notify them in advance that tests will be in progress.

1. Arm the system and fault one or more zones. After 15 seconds (if optional dialer delay is selected), silence alarm sounder(s) by entering the **code** and pressing **OFF**. Check entry/exit delay zones.
2. Check the keypad-initiated alarms that are in the system by pressing the Panic key pairs. If the system has been programmed for audible emergency, the keypad will emit a steady alarm sound, and "**ALARM**" and **zone number** will be displayed. Silence the alarm by entering the **security code** and pressing **OFF**. If the system has been programmed for silent emergency, there will be no audible alarms or displays, but a report will be sent to the central station.
3. If Powerline Carrier Devices have been installed, test their programmed action.
4. Notify the central station when all tests are finished, and verify results with them.
5. To test the wireless part of the system and the RF receiver, perform the two additional tests described in the *Installing Wireless Zones* section: Sniffer mode and Go/No Go Test.

Note: **System Test mode** (installer/master code + test) and **Go/No Go Test** (installer code + # + 8) will be **automatically terminated** after 3-1/2 to 4 hours if the installer or user does not manually terminate it. This ensures that fire and panic zones will not remain disabled. However, **Sniffer mode** (installer code + # + 3) **does not automatically expire. You must manually exit (Installer/User Code + OFF) Sniffer mode to return to normal operation.**

TO THE INSTALLER

Regular maintenance and inspection (at least annually) by the installer and frequent testing by the user are vital to continuous satisfactory operation of any alarm system.

The installer should assume the responsibility of developing and offering a regular maintenance program to the user as well as acquainting the user with the proper operation and limitations of the alarm system and its component parts. Recommendations must be included for a specific program of frequent testing (at least weekly) to ensure the system's proper operation at all times.

System Communication

This section provides an explanation of formats this system accommodates for reporting alarms and other system conditions to the central station. The process of a successful transmission consists of both the method of communication between the control panel and the central station receiver, and the actual way the information is sent and displayed at the central station.

Communication Overview

When the panel calls the central station receiver, it waits to hear a “handshake” frequency from the receiver to confirm that the receiver is on-line and ready to receive its message. Once the panel hears the handshake it is programmed to listen for, it sends its message. The panel then waits for a “kissoff” frequency from the receiver acknowledging that the message was received and understood.

If the handshake frequency is not given or is not understood by the panel, the panel will not send its message. Once the handshake frequency is received and understood by the panel, the panel will send its message. If there is an error in the transmission (the receiver does not receive a “valid” message), the kissoff frequency will not be given by the central station receiver.

The panel will make eight attempts to the primary telephone number and eight attempts to the secondary telephone number (if programmed) to get a valid message through. If the panel is not successful after its numerous attempts, the keypad will display “FC Comm Failure.” If the secondary number is a pager, “FC Comm Failure” displays after the first 8 attempts to the primary number.

The following chart defines the (handshake/kissoff) frequencies that the panel supports, and the different formats that can be sent for each.

FORMAT	HANDSHAKE	TRANSMITS DATA	KISSOFF	TRANSMIT TIME
Low Speed 3+1, 4+1, 4+2	1400Hz	1900Hz (10PPS) (Standard report)	1400Hz	Under 15 seconds
Sescoa/Radionics 3+1, 4+1, 4+2	2300Hz	1900Hz (20PPS) (Standard report)	2300Hz	Under 10 seconds
Express 4+2	1400–2300Hz	DTMF (10 cps)	1400Hz	Under 3 seconds
Contact ID®	1400–2300Hz	DTMF (10 cps)	1400Hz	Under 3 seconds

Report Code Formats

3+1 and 4+1 Standard Formats	Comprise a 3- (or 4-) digit subscriber number and a single digit report code (e.g. alarm, trouble, restore, open, close, etc).
3+1 and 4+1 Expanded Formats	Comprise a 3- (or 4-) digit subscriber number, and a 2-digit report code. The first digit is displayed on the first line, followed by a second line where the first digit is repeated 3 (or 4) times and followed by the second digit. This is the “expanded” digit.
4+2 Format	Comprises a 4-digit subscriber number and 2-digit report code.
ADEMCO Contact ID®	Comprises a 4-digit subscriber number, 1-digit event qualifier
Reporting Format	(“new” or “restore”), 3-digit event code, and 3-digit zone number, user number, or system status number (see the following page)

The following table shows the message formats for 3+1, 4+1 and 4+2 reports, where:

SSS or SSSS = Subscriber ID	C = Close Code (1st Digit)
A = Alarm Code (1st digit)	U = User Number (in hex)
Z = Typically Zone Number* (2nd digit)	Gg = Test Code (1st & 2nd digits)
Tt = Trouble Code (1st & 2nd digits)	R = Alarm Restore Code
Bb = Bypass Code (1st & 2nd digits)	R _T t = Trouble Restore Code (1st & 2nd digits)
EA _C = AC Loss Code (1st & 2nd digits)	R _B b = Bypass Restore Code (1st & 2nd digits)
LL _B = Low Battery Code (1st & 2nd digits)	R _A AC = AC Restore Code (1st & 2nd digits)
O = Open Code (1st Digit)	R _L LB = Battery Restore Code (1st & 2nd digits)

Zone numbers for: [] & [#] = 99; [1] + [*] = 95; [3] + [#] = 96; Duress = 92

System Communication

Report	3+1/4+1 Standard	3+1/4+1 Expanded	4+2
Alarm	SSS(S) A	SSS(S) A AAA(A) Z	SSSS AZ
Trouble	SSS(S) T	SSS(S) T TTT(T) t	SSSS Tt
Bypass	SSS(S) B	SSS(S) B BBB(B) b	SSSS Bb
AC Loss	SSS(S) E	SSS(S) E EEE(E) A _C	SSSS EA _C
Low Battery	SSS(S) L	SSS(S) L LLL(L) L _B	SSSS LL _B
Open	SSS(S) O	SSS(S) O OOO(O) U	SSSS OU
Close	SSS(S) C	SSS(S) C CCC(C) U	SSSS CU
Test	SSS(S) G	SSS(S) G GGG(G)g	SSSS Gg
Restore Alarm	SSS(S) R	SSS(S) R RRR(R) Z	SSSS RZ
AC Restore	SSS(S) R _A	SSS(S) R _A R _A R _A R _A (R _A)A _C	SSSSR _A A _C
Low Battery Restore	SSS(S) R _L	SSS(S) R _L R _L R _L R _L (R _L)L _B	SSSS R _L L _B
Trouble Restore	SSS(S) R _T	SSS(S) R _T R _T R _T R _T (R _T)t	SSSS R _T t
Bypass Restore	SSS(S) R _B	SSS(S) R _B R _B R _B R _B (R _B)b	SSSS R _B b

ADEMCO Contact ID® Reporting takes the following format: CCCC Q EEE GG ZZZ where:

CCCC = Customer (subscriber) ID

Q = Event qualifier, where: E = new event, and R = restore

EEE = Event code (3 hex digits) (for a complete list of event codes, refer to the central office receiver manual)

GG = Always "00"

ZZZ = Zone/Contact ID® number reporting the alarm, or user number for open/close reports. System status messages (AC Loss, Walk Test, etc.) contain zeroes in the ZZZ location.

CONTACT ID® EVENT CODES

Code	Definition
110	Fire Alarm
121	Duress
122	Alarm, 24-hour Silent
123	Alarm, 24-hour Audible
131	Alarm, Perimeter
132	Alarm, Interior
134	Alarm, Entry/Exit
135	Alarm, Day/Night
146	Silent Burglary
150	Alarm, 24-Hour Auxiliary
162	Alarm, Carbon Monoxide Detector
301	AC Power
302	Low System Battery/Battery Test Fail
344	RF Jam Detected
353	ECP Communication/Supervision failure, case tamper or low battery
373	Fire Loop Trouble
374	Exit Error Alarm

Code	Definition
380	Global Trouble, Trouble Day/Night
381	RF Supervision Trouble
383	RF Sensor Tamper (Trouble)
384	RF Sensor Low Battery
401	Disarmed, Armed AWAY (NO DELAY), Armed AWAY
403	Scheduled Auto Arm
406	Cancel by User
407	Remote Arm/Disarm (Downloading)
408	Quick Arm AWAY/NO DELAY
441	Disarmed/Armed Stay/No Delay, Quick Arm Stay/No Delay
459	Recent Close
570	Bypass
602	Periodic Test
606	AAV to follow
607	System Test
623	Event Log 80% Full
654	System Inactivity

- Notes:**
- (1) The following codes are logged in the event log upon occurrence, but are not reported:
 305 = System Reset
 627 = Keypad Program Mode Entry
 - (2) LRR/IP Communications Module Low Battery and Low Battery restore reports are sent real time. LRR/IP Communications Module trouble restore report is sent after two CODE + OFF (only if physically restored).

Troubleshooting Guide

Trouble Conditions

The word "Fault" on the keypad's display, accompanied by a rapid "beeping" at the keypad, indicates that there is a trouble condition in the system. Pressing any key can silence the audible warning sound. Instruct users to call for service immediately upon seeing any "Fault" messages.

System (including Wireless)

SYMPTOM	POSSIBLE CAUSE	REMEDY
1. Transmitter signal not received at control.	1a. Transmitter not properly powered. 1b. Transmitter is located too far from RF receiver. 1c. There is metal shielding between transmitter and RF receiver. 1d. Transmitter is malfunctioning. 1e. Transmitter No. (zone) is not programmed.	1a. Check or change transmitter's battery. 1b. Move transmitter or RF receiver. 1c. Check for large metal obstructions, then relocate transmitter if necessary. 1d. Verify by activating control with another, similar transmitter. If O.K. now, return defective transmitter. 1e. Verify programming.
2. Transmitter zone number appears during Transmitter Sniffer mode, but does not clear.	2a. Transmitter zone type (ZT) is set to 00 (Not Used). 2b. Transmitter battery not installed. 2c. 5800 System transmitter not "enrolled" in system.	2a. Set ZT to a valid active zone type in field *56. 2b. Install proper battery. 2c. "Enter" unit in field *56 or *83.
3. Low battery message on keypad. 3a. "Low Bat" (no zone Nos.) 3b. "Low Bat" + "00". 3c. "Low Bat" + "nn".	3a. System battery is low or missing. 3b. Remote RF keypad/button battery is low. 3c. Transmitter for zone "nn" has a low battery. 3d. Standard- or High-Capacity battery connected to wrong receptacle.	3a. Replace system battery. 3b. Replace battery in the RF keypad. 3c. Replace the battery in the displayed transmitter. 3d. Ensure that battery is properly connected.
4. Periodic beep(s) from keypad.	4a. System is in Test mode. 4b. A transmitter low battery has occurred and is displayed. 4c. A supervision fault has occurred. 4d. System low battery	4a. Enter Code + OFF to exit Test mode. 4b. Enter Code + OFF and replace the battery. 4c. Check the transmitter indicated. Restore communication to the receiver to cancel the condition. 4d. Replace system battery
5. There is no response to a transmitter in normal operation, although zone number clears during Transmitter Sniffer mode.	Put control in Test mode. If zone does not respond, try operating the tamper switch or another input to the transmitter. 5a. If another input causes the zone to be displayed, the wrong input was "entered" when programming. 5b. If no response at all from this transmitter, this physical transmitter has not been entered by the system. Transmitter Sniffer display is being cleared by another unit programmed for this zone.	5a. Delete input's serial number (not the zone), and enter the proper input (see field *56). 5b. Determine which transmitter is programmed for this zone and reprogram as necessary.
6. Nuisance or phantom alarm.	6a. Sensors not properly installed, wired, or monitored. 6b. Universal transmitter (5817) programmed wrong.	6a. Check installation to see if in accordance with established procedure. 6b. Check programming switches on transmitter.
7. Intrusion alarm for no apparent reason.	7a. Protected door or window opened while system armed. 7b. Improper user operation of exit/entry delays. 7c. Magnets located too far from switches, and/or doors and windows not properly aligned.	7a. Check with all occupants of protected home. 7b. Check setting of entry and exit delays. 7c. Check all openings for proper switch and magnet orientation.

Troubleshooting Guide

Control

SYMPTOM	POSSIBLE CAUSE	REMEDY
1. "No AC" is displayed.	1a. Interrupted AC power supply.	1a. Check transformer connection and powerline circuit breaker.
2. Digital communicator message not being received.	2a. System in Test mode. 2b. Telephone connection not secure. 2c. Digital communicator malfunctioning. 2d. Telephone number in program needs prefix or access code. 2e. Telephone call to central monitoring station requires operator assistance.	2a. Remove from Test mode. 2b. Check all connections. 2c. Check with a different CONTROL PANEL. 2d. Program prefix or access code into the CONTROL PANEL. 2e. System cannot work in this situation.
3. Does not arm properly. READY light not on.	3a. Open or faulted zone(s)	3a. Check for faulted zones and make intact, or use Bypass arming, if desired.
4. System doesn't respond to keystrokes on keypad. 4a. "CC" displayed. 4b. "d1" displayed.	4a. System is in communication with downloader at central station. 4b. System has just been powered and is in its one minute initialization.	4a. Wait until download session is finished. 4b. Wait for initialization to finish, or bypass this time by pressing '#' + '0.'

Smoke Detectors

SYMPTOM	POSSIBLE CAUSE	REMEDY
1. Detector alarms, no apparent reason.	1a. Dust, dirt in sensing chamber. 1b. Improper location. 1c. Unit malfunctioning.	1a. Clean unit's sensing chamber with vacuum cleaner per unit's instructions. 1b. See unit's instructions for locations to avoid. Relocate as necessary. 1c. Replace detector.
2. Detector's siren sounds.	2a. Unit not receiving required power. 2b. Unit malfunctioning.	2a. Check for proper installation of battery. Try new battery. 2b. Replace detector.

Programming Default Tables

ReadyGuard Plus Defaults

(boldface indicates defaults that differ between tables)

Function	Table 1	Table 2	Table 3	Table 4
*20 Installer code	4112	4112	4112	4112
*21 Quick arm enable	1	1	1	1
*22 Keypad backlight timeout	0	0	0	0
*23 Forced bypass	0	0	0	0
*24 RF house ID code	0,0	0,0	0,0	0,0
*25 Powerline carrier device house code	0	0	0	0
*26 Chime-by-zone	0	0	0	0
*27 Real-time clock display	1	1	1	1
*29 Daylight saving time start/end month	3,11	3,11	3,11	3,11
*30 Daylight saving time start/end weekend	2,1	2,1	2,1	2,1
*31 Single alarm sounding per zone	0	0	0	0
*32 Sounder timeout	0	0	0	0
*33 Alarm bell timeout	1	1	1	1
*34 Exit delay	7,0	6,0	7,0	7,0
*35 Entry delay 1 (zone type 01)	3,0	4,5	3,0	3,0
*36 Entry delay 2 (zone type 02)	6,0	6,0	6,0	6,0
*37 Audible exit warning/quick exit	1,1	0,1	1,1	1,1
*38 Confirmation of arming ding	0	0	0	0
*39 Power up in previous state	1	1	1	1
*40 PABX access code	---	---	---	---
*41 Primary phone number	---	---	---	---
*42 Secondary phone number	---	---	---	---
*43 Primary subscriber account number	15,15,15,15	15,15,15,15	15,15,15,15	15,15,15,15
*44 Secondary subscriber account number	15,15,15,15	15,15,15,15	15,15,15,15	15,15,15,15
*46 "Follow Me Reminder" Phone Number	---	---	---	---
*47 Phone system select	5	5	5	5
*48 Report format	7,7	7,7	7,7	7,7
*49 Split/dual reporting	0	0	0	9
*50 15 second dialer delay (burglary)	0	1	0	0
*51 Periodic test report	0	3	0	0
*52 First test report offset	2	2	2	2
*53 Sescoa/radionics select	0	0	0	0
*54 Lack of usage notification	0	0	0	0
*55 Reporting Channels	0	0	0	0
*56 Enhanced Zone programming	See *56 table	See *56 table	See *56 table	See *56 table
*58 RF jam detection	0	0	0	0
*59 Exit error report code	1	0	1	1
*60 Trouble report code	1,0	1,0	1,0	1,0
*61 Bypass report code	0,0	0,0	0,0	0,0
*62 AC loss report code	0,0	0,0	0,0	0,0
*63 Low battery Report code	1,0	1,0	1,0	1,0
*64 Test report code	1,0	1,0	1,0	1,0
*65 Open report code	0	0	0	0
*66 Arm away/stay report code	0,0	0,0	0,0	0,0
*67 RF transmitter low battery report code	1,0	1,0	1,0	1,0
*68 Cancel report code	1,0	1,0	1,0	1,0
*70 Alarm restore codes	1	1	1	1
*71 Trouble restore report code	1,0	1,0	1,0	1,0
*72 Bypass restore report code	0,0	0,0	0,0	0,0
*73 AC restore report code	0,0	0,0	0,0	0,0
*74 Low battery restore report code	1,0	1,0	1,0	1,0
*75 RF transmitter low battery restore report code	1,0	1,0	1,0	1,0
*76 Test restore report code	0,0	1,0	0,0	0,0
*77 Dynamic Signaling Delay/ Dynamic Signaling Priority	0,0	0,0	0,0	0,0
*78 Programmable Tone Generation Time	0,0	0,0	0,0	0,0
*80 Powerline Carrier Devices	See *80 table	See *80 table	---	See *80 table
*81 Zone lists for devices	See *81 table	See *81 table	See *81 table	See *81 table
*84 Assign zone voice descriptors	Refer to *84 Programming			
*86 Multi-mode (E-mail notification)	0	0	0	0

Programming Default Tables

ReadyGuard Plus Defaults

(boldface indicates defaults that differ between tables)

Function	Table 1	Table 2	Table 3	Table 4
*87 Auxiliary Function/ 1-button paging	0	1	0	1
*88 Pager characters	---	---	---	---
*89 Event log 80% full report code	0,0	0,0	0,0	0,0
*90 Event logging	3	15	3	3
*91 Alarm audio verification/remote phone control	2	2	2	2
*92 Number of reports in armed period	0	0	0	0
*93 Flexible call back	0	0	0	0
*94 Download phone number	---	---	---	---
*95 Ring detect count for downloading/remote phone control	15	15	15	15
Default Master Code	1,2,3,4	1,2,3,4	1,2,3,4	1,2,3,4
Default Duress Code	---	---	---	---

By activating *96, Field 43, and 44 will be changed to 15, 15, 15, 15.

*56 ZONE ASSIGNMENT/ALARM REPORT CODES FOR TABLE 1

Zone No.	Zone Type	Alarm Code	Input Type	Loop Number	Zone Descriptor
1	00	0,0	---	---	
2	01	1,0	3 (RF)	2	47, 04 (FRONT DOOR)
3	01	1,0	3 (RF)	2	33, 04 (BACK DOOR)
4	03	1,0	3 (RF)	2	80 (WINDOW)
5	10	1,0	3 (RF)	1	56 (MOTION DETECTOR)
26	21	1,0	5 (BR)	3	
27	22	1,0	5 (BR)	2	
28	20	1,0	5 (BR)	4	
29	23	0,0	5 (BR)	1	
30	21	1,0	5 (BR)	3	
31	22	1,0	5 (BR)	2	
32	20	1,0	5 (BR)	4	
33	23	0,0	5 (BR)	1	
92	---	1,0	---	---	
99	06	1,0	---	---	

NOTE: Zone 1 is a hardwire zone; Zone 2 to 41 are RF zones; Zone 92 is Duress; Zone 99 is keypad panic

*56 ZONE ASSIGNMENT/ALARM REPORT CODES FOR TABLE 2

Zone No.	Zone Type	Alarm Code	Input Type	Loop Number	Zone Descriptor
1	00	0,0	---	---	
2	01	1,0	3 (RF)	2	47, 04 (FRONT DOOR)
3	01	1,0	3 (RF)	2	33, 04 (BACK DOOR)
4	01	1,0	3 (RF)	2	48, 04 (GARAGE DOOR)
5	04	1,0	3 (RF)	1	56 (MOTION DETECTOR)
6	09	1,0	3 (RF)	1	22, 02 (SMOKE DETECTOR)
26	21	1,0	5 (BR)	3	
27	22	1,0	5 (BR)	2	
28	20	1,0	5 (BR)	4	
29	23	0,0	5 (BR)	1	
30	21	1,0	5 (BR)	3	
31	22	1,0	5 (BR)	2	
32	20	1,0	5 (BR)	4	
33	23	0,0	5 (BR)	1	
92	---	1,0	---	---	
95	08	1,0	---	---	
96	09	1,0	---	---	
99	07	1,0	---	---	

NOTE: Zone 1 is a hardwire zone; Zone 2 to 41 are RF zones; Zone 92 is Duress; Zones 95, 96 and 99 are keypad panics

Programming Default Tables

*56 ZONE ASSIGNMENT/ALARM REPORT CODES FOR TABLES 3 & 4

Zone No.	Zone Type	Alarm Code	Input Type	Loop Number	Zone Descriptor
1	00	0,0	---	---	
2	01	1,0	3 (RF)	2	47, 04 (FRONT DOOR)
3	01	1,0	3 (RF)	2	33, 04 (BACK DOOR)
4	03	1,0	3 (RF)	2	80 (WINDOW)
5	03	1,0	3 (RF)	2	80 (WINDOW)
6	03	1,0	3 (RF)	2	80 (WINDOW)
7	03	1,0	3 (RF)	2	80 (WINDOW)
8	10	1,0	3 (RF)	1	56 (MOTION DETECTOR)
9	09	1,0	3 (RF)	1	22, 02 (SMOKE DETECTOR)
26	21	1,0	5 (BR)	3	
27	22	1,0	5 (BR)	2	
28	23	0,0	5 (BR)	4	
29	23	0,0	5 (BR)	1	
30	21	1,0	5 (BR)	3	
31	22	1,0	5 (BR)	2	
32	23	0,0	5 (BR)	4	
33	23	0,0	5 (BR)	1	
92	---	1,0	---	---	
99	06	1,0	---	---	

NOTE: Zone 1 is a hardwire zone; Zone 2 to 41 are RF zones; Zone 92 is Duress; Zone 99 is keypad panic

*80 DEFAULT TABLE: Applies to Default Tables 1 and 2

(devices 01-07 have no default values, devices 09-15 have all default values set to 00)

Device Number	Action	Start			Stop	
		Event	Zone List	Zone Type System Operation	Restore of Zone List	Zone type System operation
08**	2			33		36
16	2			33		36

*80 DEFAULT TABLE: Applies to Default Table 4

(devices 02-07 have no default values, devices 10-15 have all default values set to 00)

Device Number	Action	Start			Stop	
		Event	Zone List	Zone Type System Operation	Restore of Zone List	Zone type System operation
01	2	2	1		2	
08**	2			33		36
09	2	2	1		2	
16	2			33		36

** **NOTE:** If using an X10 Powerhouse Security SH10A siren as device 08, you must change the device action default to "3".

*81 DEFAULT TABLE: Applies to Default Tables 1 - 4 ZONE LIST FOR OUTPUT DEVICES

Zone List 1	28, 32
Zone List 2	29, 33
Zone List 3	2, 3

Regulatory Agency Statements

FCC STATEMENTS

Federal Communications Commission (FCC) Part 15 Statement

The user shall not make any changes or modifications to the equipment unless authorized by the Installation Instructions or User's Manual. Unauthorized changes or modifications could void the user's authority to operate the equipment.

CLASS B DIGITAL DEVICE STATEMENT

NOTE: This equipment has been tested and found to comply with the limits for a Class B digital device, pursuant to part 15 of the FCC Rules. These limits are designed to provide reasonable protection against harmful interference in a residential installation. This equipment generates, uses and can radiate radio frequency energy and, if not installed and used in accordance with the instructions, may cause harmful interference to radio communications. However, there is no guarantee that interference will not occur in a particular installation. If this equipment does cause harmful interference to radio or television reception, which can be determined by turning the equipment off and on, the user is encouraged to try to correct the interference by one or more of the following measures:

- Reorient or relocate the receiving antenna.
- Increase the separation between the equipment and receiver.
- Connect the equipment into an outlet on a circuit different from that to which the receiver is connected.
- Consult the dealer or an experienced radio/TV technician for help.

INDUSTRY CANADA (IC) STATEMENTS

This device complies with RSS210 of Industry Canada. Operation is subject to the following two conditions: (1) This device may not cause harmful interference, and (2) This device must accept any interference received, including interference that may cause undesired operation.

This Class B digital apparatus complies with Canadian ICES-003.

Cet appareil numérique de la classe B est conforme à la norme NMB-003 du Canada.

Federal Communications Commission (FCC) Part 68

This equipment complies with Part 68 of the FCC rules. On the front cover of this equipment is a label that contains the FCC registration number and Ringer Equivalence Number (REN). You must provide this information to the telephone company when requested.

This equipment uses the following USOC jack: RJ31X

This equipment may not be used on telephone-company-provided coin service. Connection to party lines is subject to state tariffs.

This equipment is hearing-aid compatible.

Industry Canada

NOTICE: The Industry Canada Label identifies certified equipment. This certification means that the equipment meets telecommunications network protective, operational and safety requirements as prescribed in the appropriate Terminal Equipment Technical Requirements document(s). The Department does not guarantee the equipment will operate to the user's satisfaction. Before installing this equipment, users should ensure that it is permissible to be connected to the facilities of the local telecommunications company. The equipment must also be installed using an acceptable method of connection. The customer should be aware that compliance with the above conditions may not prevent degradation of service in some situations.

Repairs to certified equipment should be coordinated by a representative designated by the supplier. Any repairs or alterations made by the user to this equipment, or equipment malfunctions, may give the telecommunications company to request the user to disconnect the equipment.

Users should ensure for their own protection that the electrical ground connections of the power utility, telephone lines and internal metallic water pipe system, if present, are connected together. This precaution may be particularly important in rural areas.

Caution: Users should not attempt to make such connections themselves but should contact appropriate electric inspection authority, or electrician, as appropriate.

Ringer Equivalence Number Notice:

The **Ringer Equivalence Number** (REN) assigned to each terminal device provides an indication of the maximum number of terminals allowed to be connected to a telephone interface. The termination on an interface may consist of any combination of devices subject only to the requirement that the sum of the Ringer Equivalence Numbers of all the devices does not exceed 5.

WARNING
THE LIMITATIONS OF THIS ALARM SYSTEM

While this System is an advanced design security system, it does not offer guaranteed protection against burglary, fire or other emergency. Any alarm system, whether commercial or residential, is subject to compromise or failure to warn for a variety of reasons. For example:

- Intruders may gain access through unprotected openings or have the technical sophistication to bypass an alarm sensor or disconnect an alarm warning device.
- Intrusion detectors (e.g., passive infrared detectors), smoke detectors, and many other sensing devices will not work without power. Battery-operated devices will not work without batteries, with dead batteries, or if the batteries are not put in properly. Devices powered solely by AC will not work if their AC power supply is cut off for any reason, however briefly.
- Signals sent by wireless transmitters may be blocked or reflected by metal before they reach the alarm receiver. Even if the signal path has been recently checked during a weekly test, blockage can occur if a metal object is moved into the path.
- A user may not be able to reach a panic or emergency button quickly enough.
- While smoke detectors have played a key role in reducing residential fire deaths in the United States, they may not activate or provide early warning for a variety of reasons in as many as 35% of all fires, according to data published by the Federal Emergency Management Agency. Some of the reasons smoke detectors used in conjunction with this System may not work are as follows. Smoke detectors may have been improperly installed and positioned. Smoke detectors may not sense fires that start where smoke cannot reach the detectors, such as in chimneys, in walls, or roofs, or on the other side of closed doors. Smoke detectors also may not sense a fire on another level of a residence or building. A second floor detector, for example, may not sense a first floor or basement fire. Finally, smoke detectors have sensing limitations. No smoke detector can sense every kind of fire every time. In general, detectors may not always warn about fires caused by carelessness and safety hazards like smoking in bed, violent explosions, escaping gas, improper storage of flammable materials, overloaded electrical circuits, children playing with matches, or arson. Depending on the nature of the fire and/or location of the smoke detectors, the detector, even if it operates as anticipated, may not provide sufficient warning to allow all occupants to escape in time to prevent injury or death.
- Passive Infrared Motion Detectors can only detect intrusion within the designed ranges as diagrammed in their installation manual. Passive Infrared Detectors do not provide volumetric area protection. They do create multiple beams of protection, and intrusion can only be detected in unobstructed areas covered by those beams. They cannot detect motion or intrusion that takes place behind walls, ceilings, floors, closed doors, glass partitions, glass doors, or windows. Mechanical tampering, masking, painting or spraying of any material on the mirrors, windows or any part of the optical system can reduce their detection ability. Passive Infrared Detectors sense changes in temperature; however, as the ambient temperature of the protected area approaches the temperature range of 90° to 105°F (32° to 40°C), the detection performance can decrease.
- Alarm warning devices such as sirens, bells or horns may not alert people or wake up sleepers if they are located on the other side of closed or partly open doors. If warning devices are located on a different level of the residence from the bedrooms, then they are less likely to waken or alert people inside the bedrooms. Even persons who are awake may not hear the warning if the alarm is muffled by noise from a stereo, radio, air conditioner or other appliance, or by passing traffic. Finally, alarm warning devices, however loud, may not warn hearing-impaired people.
- Telephone lines needed to transmit alarm signals from a premises to a central monitoring station may be out of service or temporarily out of service. Telephone lines are also subject to compromise by sophisticated intruders.
- Even if the system responds to the emergency as intended, however, occupants may have insufficient time to protect themselves from the emergency situation. In the case of a monitored alarm system, authorities may not respond appropriately.
- This equipment, like other electrical devices, is subject to component failure. Even though this equipment is designed to last as long as 10 years, the electronic components could fail at any time.

The most common cause of an alarm system not functioning when an intrusion or fire occurs is inadequate maintenance. This alarm system should be tested weekly to make sure all sensors and transmitters are working properly. The security keypad (and remote keypad) should be tested as well.

Wireless transmitters (used in some systems) are designed to provide long battery life under normal operating conditions. Longevity of batteries may be as much as 4 to 7 years, depending on the environment, usage, and the specific wireless device being used. External factors such as humidity, high or low temperatures, as well as large swings in temperature, may all reduce the actual battery life in a given installation. This wireless system, however, can identify a true low battery situation, thus allowing time to arrange a change of battery to maintain protection for that given point within the system.

Installing an alarm system may make the owner eligible for a lower insurance rate, but an alarm system is not a substitute for insurance. Homeowners, property owners and renters should continue to act prudently in protecting themselves and continue to insure their lives and property.

We continue to develop new and improved protection devices. Users of alarm systems owe it to themselves and their loved ones to learn about these developments.

Specifications

ReadyGuard Plus Security Controls

1. **Physical:** 8-3/4" W x 6-3/4" H x 1-3/4" D
2. **Electrical:**
VOLTAGE INPUT: 9VAC from plug-in 25VA transformer.
RECHARGEABLE BACKUP BATTERY: Nickel-metal hydride battery pack rated at 7.7Vdc.
ALARM SOUNDER: Bell = 6-14VDC, 120mA max (e.g., ADEMCO's WAVE2EX).
3. **Communication:**
FORMATS SUPPORTED:
ADEMCO Express, 10 characters/sec, DTMF (TouchTone) Data Tones, 1400/2300Hz ACK, 1400Hz KISSOFF.
ADEMCO Contact ID® Reporting, 10 characters/sec., DTMF (TouchTone) Data Tones, 1400/2300Hz ACK, 1400Hz KISSOFF.
ADEMCO Low Speed, 10 pulses/sec, 1900Hz Data Tone, 1400Hz ACK/KISSOFF.
Radionics/SESCOA, 20 pulses/sec, 1800Hz Data Tone, 2300Hz ACK/KISSOFF. Can report 0-9, B-F.
Line Seize: Double Pole
Ringer Equivalence: 0.6B
FCC Registration No.: 5GBUSA-25623-AL-E

UL NOTICES

1. For UL Residential Burglar Alarm installations with line security, total exit delay time must not exceed 60 seconds. For UL Burglar Alarm installations without line security, total exit delay time must not exceed 120 seconds.
2. Periodic testing (see scheduling mode) must be at least every 24 hours.
3. Alarm Sounder plus Auxiliary Power currents must not exceed 600mA total for UL installations (Aux power 500mA max.).
4. Remote downloading without an alarm company technician on-site (unattended downloading) is not permissible for UL installations.
5. Auto-disarming is not a UL Listed feature.

Contacting Technical Support

PLEASE, before you call Technical Support, be sure you:

- **READ THE INSTRUCTIONS!**
- **Check all wiring connections.**
- **Determine that the power supply and/or backup battery are supplying proper voltages.**
- **Verify your programming information where applicable.**
- **Note the proper model number of this product, and the version level (if known) along with any documentation that came with the product.**
- **Note your Honeywell customer number and/or company name.**

Having this information handy will make it easier for us to serve you quickly and effectively.

Technical Support: 1-800-645-7492 (8 a.m.-10 p.m. E.S.T.)

FAX FAXBACK Automated Fax Retrieval System: 1-800-573-0153

World Wide Web Address: <http://www.honeywell.com/security>

WARRANTY INFORMATION

For the latest warranty information, please go to:

www.honeywell.com/security/hsc/resources/wa

- Index -

*56 Enhanced zone programming mode	13, 17, 35
*80 Device programming menu mode	17, 40
*81 Zone list menu mode	17, 44
*83 Enhanced sequential mode	17, 35, 37, 45
*84 Assign zone voice descriptors	17, 38, 39, 48, 49
*85 Record custom voice descriptors	17, 50
*96 Initialize download id and subscriber account.	
Number. For downloading	17
15 second dialer delay	25, 63
24-hour audible alarm	18
24-hour carbon monoxide monitor	19
24-hour silent alarm	18, 53
5800 series transmitters	13
5800RL	13
5801	13
5802MN	13, 14
5802MN2	14
5804	13, 14
5804BD/5804BDV	13, 14, 20
5804E	13, 14
5816	13
5817	13
5827	13

A

AC loss report code	63
AC power	11, 12
AC power and rechargeable backup battery	12
AC power loss	11
AC restore report code	63
Ademco express	24, 68
Ademco low speed	24, 68
Alarm bell timeout	63
Alarm restore codes	63
Alarm sounder	68
Arm away/stay report code	63
Arm-away	19
Armed system test	58
Arm-stay	19
Assign (or change) a secondary security code	53
Assign zone voice descriptors	48, 63
Audible exit warning/quick exit	63
Audio alarm verification (two-way voice feature)	57
Aux function/1-button paging	64
Aux key	32

B

Babysitter code	53
Backlighting	20
Backup battery	11, 12
Backup reporting	23
Battery life	13
Bell	68
BR	13, 36
Burglary zones	21
Busy-standby	55
Button transmitters	13, 14
Button type	36
Bypass	56
Bypass report code	63
Bypass restore report code	63

C

Callback number	33
Cancel report code	63
Canceled alarm	28
Change the master code	53
Chime mode	20
Chime-by-zone	63
Closing report	22
Communication overview	59
Confirmation of arming ding	63
Connecting/configuring communication modules	9, 10
Contact ID event codes	60
Contact ID format	28
Contact ID reporting	60, 68
Contacting technical support	68
Custom voice descriptors	17, 50

D

Data encryption	51
Data field	16
Data field descriptions	20
Daylight savings time start/end	63
Default master code	64
Delete a secondary security code	53
Delete zone parameters confirmation	37
Desktop mounting	6
Dip switches	13
Disable local sounder	8
Disarm	19
Download phone number	64
Download, initial	51
Downloader	32
Duress code	53
Dynamic signaling delay	30, 31
Dynamic signaling priority	30

E

Encrypted (high-security) devices	14, 15, 36
Enter/change the master code	53
Entering program mode	16
Entry delay	63
Entry/exit burglary	18
Error code 374	28
Event log 80% full report code	64
Event logging	32, 64
Exit alarm	28
Exit delay	22, 63
Exit door	21
Exit error alarm displays	55
Exit error report code	63
Exit warning	22
Exiting program mode	17
Expert programming	16
External sounder	21
External sounder connections	8

ReadyGuard Plus Installation and Setup Guide

F	
Fault	56, 61
FC	59
FCC statement	66
Features	5
Fire sounder timeout	63
First test report offset	63
Flexible callback	51, 64
Follow me reminder feature	54
Follow me system announcement	54
Forced bypass	63
Full line seizure	7

G	
General programming information	16
Go/no go test	14

H	
Handshake frequency	59
Hardwired zone connections	8
Hayes	51
House ID	20
House identification	13

I	
Input type	13, 36
Installer code	53, 63
Interactive menu mode programming	17
Interior with delay	19

K	
K10145	11
K10145CN	11
Keypad backlight timeout	63
Keypad operation	53
Keys	13
Kissoff frequency	59

L	
Loading factory defaults	17
Local seizure	7
Long range radio and internet communication devices	9
Loop and serial number	36
Loop number	36
Low battery report code	63
Low battery restore report code	63
LYNX-DM	6
LYNXRCHKIT-HC	12
LYNXRCHKIT-SC	12

M	
Macro function	32
Master code	53
Master security code	20
Memory of alarm	53
Message	56
Mounting base	6

N	
No alarm response	19
Number of reports in armed period	64

O	
Open report code	63
Operator commands	57
Optima 24 plus fax96 modem	51

P	
PABX access code	63
Pager characters	64
Pager message	32
Pager report format	25
Paging feature	32
Panic keys	53
Perimeter burglary	18
Periodic test report	63
Phone system select	63
Plug-in transformer	11
Power up in previous state	63
Powerline carrier device	20, 40, 63
Powerline carrier device connections	8
Powerline carrier device house code	63
Powerline carrier device programming	41
Primary phone number	63
Primary subscriber account number	63
Programming default tables	63

Q	
Quick arm enable	63
Quick exit	22

R	
Radionics	24
Radionics/sescoa	68
Range	13
Real-time clock display	63
Rec	56
Redundant reporting/dynamic signaling delay	63
Remote phone control	54
Remote programming	51
Remote programming/control	51
Replacing the rechargeable battery	12
Report code formats	59
Report codes	27
Report format	63
RF	36
RF (supervised RF)	13
RF houseID code	63
RF transmitter low battery report code	63
RF transmitter low battery restore	63
Ring detect count for downloading	64

S		U	
Scheduling	51	Unsupervised button RF	13
Secondary phone number	63	Unsupervised RF	13
Secondary subscriber account number	63	UR (unsupervised RF)	13, 36
Secondary user codes	53	V	
Security code handshake	51	Voice descriptor	35, 48
Security codes	20, 53	Voice prompt programming mode	16
Serial number	17, 35, 37	Voltage input	68
Sescoa/radionics select	63	W	
SH10A	41	Wall mounting	6
Silent burglary	19	WAVE2EX	68
Single alarm sounding per zone	63	Wireless buttons	13
Siren/horn	41	Wireless transmitter	28
Site-initiated remote programming	51	Wireless zones	13
Smartmodem 1200	51	Wiring connections	7
Sniffer mode	14, 58, 61	World wide web address	68
Split/dual reporting	63	X	
Start by zone type	40	X10	40, 51
Station-initiated remote programming	51	Z	
Supervised fire	19	Zone entry to list	44
Supervised RF	13, 36	Zone list	65
System battery	61	Zone lists	17, 63
System communication	59	Zone number	35
System displays	55	Zone programming	63
System features	5	Zone response type	18
System operation	40, 53, 65	Zone type	35
System words	49		
T			
Technical support	68		
Telco handoff	51		
Temporal pulse	21		
Test mode	58, 61, 62		
Test report code	63		
Test restore report code	63		
Testing the system	58		
Transmitter loop numbers	15		
Transmitter supervision	13		
Transmitters	13		
Trouble by day/	18		
Trouble conditions	61		
Trouble report code	63		
Trouble restore report code	63		
Troubleshooting guide	61		

UL INSTALLATIONS
THE MINIMUM WIRE
SIZE USED FOR
TELEPHONE
INSTALLATIONS
MUST BE #26 GAGE

WARNING
TO PREVENT RISK OF
SHOCK DISCONNECT
AT TELEPHONE JACK
BEFORE SERVICING
THIS UNIT

UL EXTERNAL SOUNDERS AND POWERLINE CARRIER DEVICES HAVE NOT BEEN EVALUATED BY UL.

POWER SHUTDOWN NOTE: AT 6.0VDC THE SYSTEM WILL NOT OPERATE.

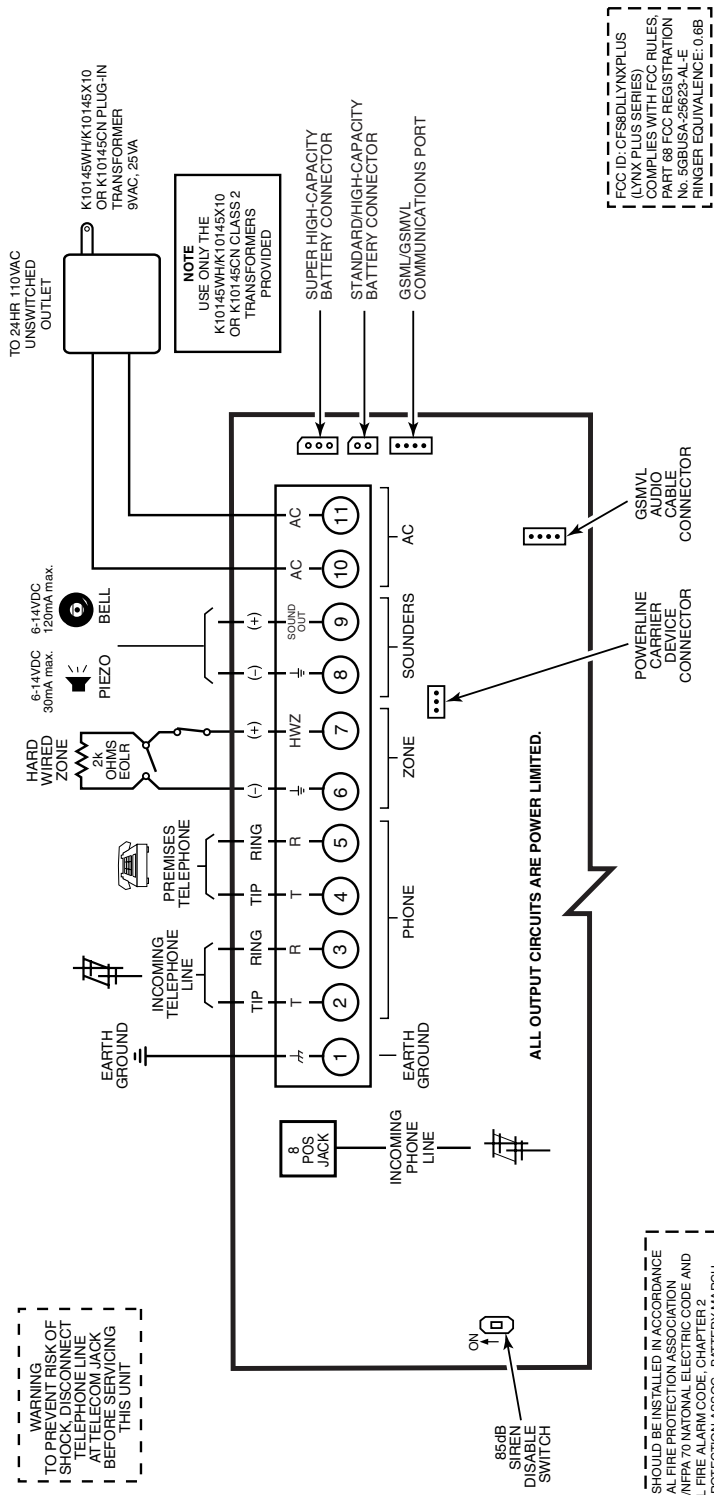

FCC ID: CFS80LYNX PLUS
(LYNX PLUS SERIES)
COMPLIES WITH FCC RULES
PART 68 FCC REGISTRATION
No. 5GBUSA-25623-A-LE
RINGER EQUIVALENCE: 0.68B

THE READYGUARD PLUS SERIES CONTROLS
ARE COMPATIBLE WITH THE FOLLOWING
INTEGRAL RECHARGEABLE BATTERY PACKS:
P/N LYNXFRCHKIT-SC
P/N LYNXFRCHKIT-HC
P/N LYNXFRCHKIT-SHA
REPLACE EVERY FOUR YEARS

WARNING
THIS UNIT MAY BE PROGRAMMED TO INCLUDE AN ALARM VERIFICATION FEATURE THAT WILL RESULT IN A DELAY OF THE SYSTEM ALARM SIGNAL FROM THE INDICATED FIRE CIRCUITS. THE TOTAL DELAY (CONTROL UNIT PLUS SMOKE DETECTORS) SHALL NOT EXCEED 60 SECONDS. NO OTHER INITIATING DEVICES SHALL BE CONNECTED TO THESE CIRCUITS UNLESS APPROVED BY THE LOCAL AUTHORITY HAVING JURISDICTION.

CIRCUIT (ZONE)	CONTROL UNIT DELAY-SEC	SMOKE DETECTOR MODEL	DELAY-SEC
02 - 25 Z116	30 seconds	5806	10 seconds

WEEKLY TESTING IS
REQUIRED TO ENSURE
PROPER OPERATION
OF THIS SYSTEM

ALL OUTPUT CIRCUITS ARE POWER LIMITED.

Notes: Connection of the fire alarm signal to a fire alarm headquarters or a central station shall be permitted with the approval of the local authority having jurisdiction. The burglar alarm signal shall not be connected to a police emergency number. The System must be checked by a qualified technician once every three years

READYGUARD PLUS SERIES SUMMARY OF CONNECTIONS