

The optional ACC-AAM25 Audio Amplifier Module is identical to the module provided with the factory standard panel configuration. It can be used to provide a second 25 watt speaker circuit, increasing the total speaker power to 50 watts, or it can be used as a backup amplifier. Connector J1 on the Audio Amplifier Module plugs into connector P3 located at the bottom center of the main circuit board.

ACC-AAM25 Audio Amplifier Module Product Installation Drawing

Document 51945 Rev A 05/06/02 ECN 02-056

CAUTION! Make certain all power (AC and DC) is removed before any connections are made.

ACC-AAM25 Audio Amplifier Module installation on main circuit board (see Figure 1)

IMPORTANT! The ACC-AAM25 Audio Amplifier Module with ACCAAM25-PCB stamped on the circuit board can ONLY be installed on Main Circuit boards with ACCMCB-PCA stamped on the circuit board.

1. For ease of access, all wiring should be connected to the terminals on the main circuit board terminal blocks TB8, TB9, TB10 and TB1 prior to installing the secondary Audio Amplifier Module.
2. Remove one mounting screw from the main circuit board and save (refer to illustration below for location).
3. Install one supplied metal standoff in location from which mounting screw was removed in step 2.
4. Install the Audio Amplifier Module by carefully aligning the amplifier's J1 connector with the P3 connector on the main circuit board. Press the Audio Amplifier Module securely into place making certain not to bend or break any connector pins.
5. Secure the Audio Amplifier Module with the supplied screws plus the screw removed in step 2. It is important that the module be secured with the metal screws in order to help protect against electrical transients.
6. Configure the Audio Amplifier for normal or backup operation by setting switch S1 on the newly installed audio amplifier:
 - (1) Position switch S1 in the 'down' position for normal operation. This adds an additional 25 watts increasing total system output to 50 watts.
 - (2) Position switch S1 in the 'up' or 'Backup On' position to configure the amplifier as a backup in the event the primary amplifier fails to operate.
7. Connect field wiring to amplifier as illustrated on the following page and fully test the system.
8. Make certain the factory installed jumpers are in place on connector P1 of the Audio Amplifier Module. Refer to Figure 1.

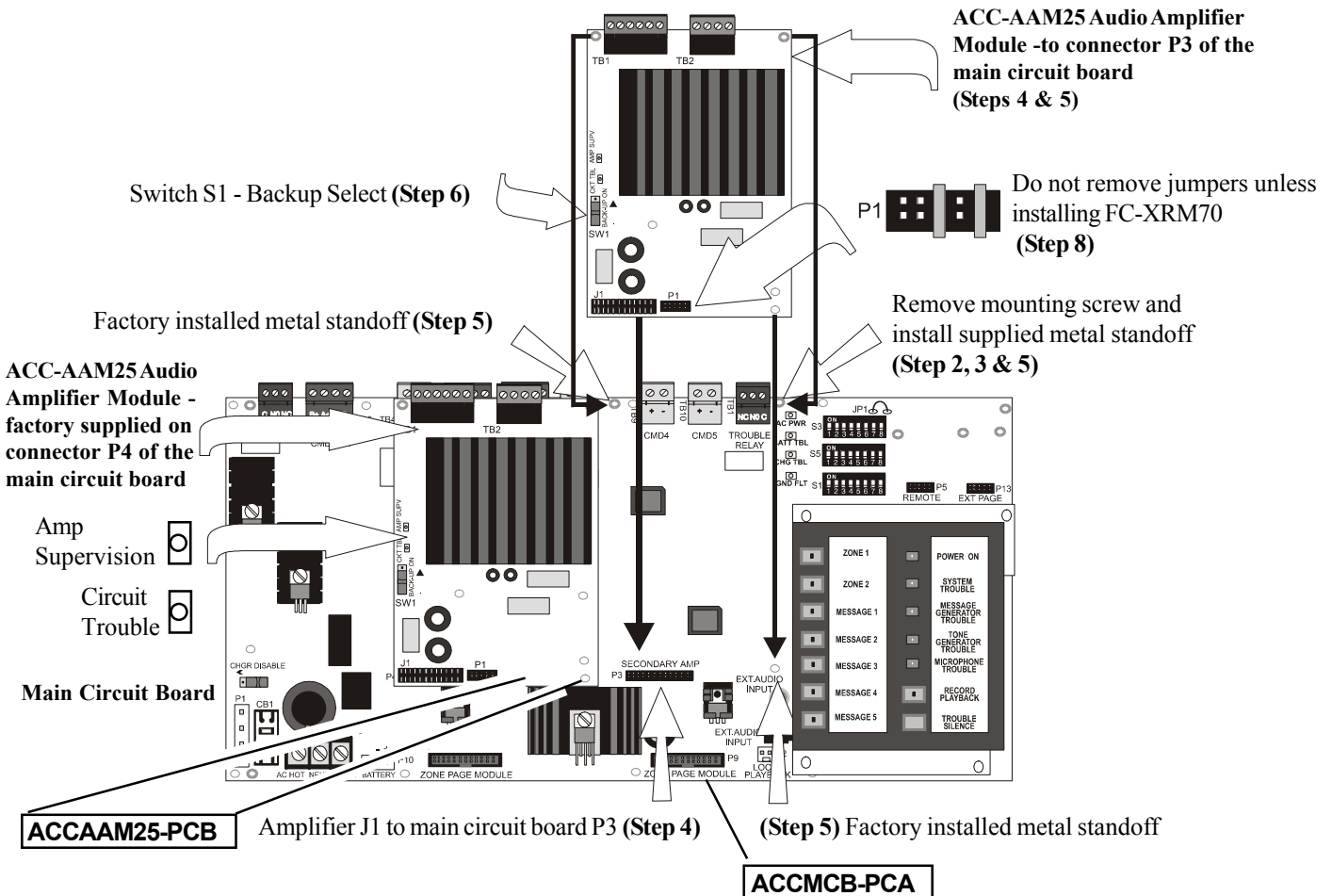
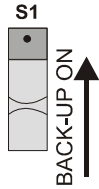

Figure 1: Main Circuit Board

4.75 K, 1 watt EOL
(Style Y Only)
Circuit is supervised
and power-limited



Switch S1 in
'Down'
position

Style Z

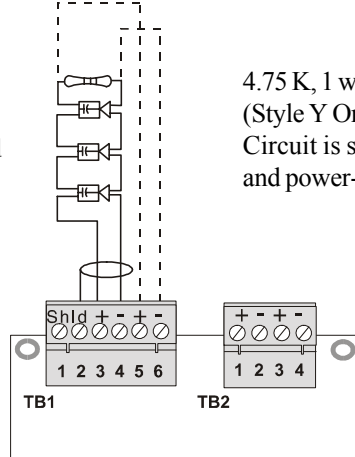

**First Amplifier
Mounted on Main Board**

4.75 K, 1 watt EOL
(Style Y Only)
Circuit is supervised
and power-limited

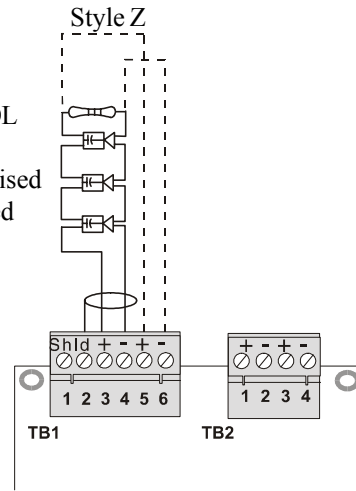

**Second Amplifier
Mounted on Main Board**

**Second amplifier adds an additional 25
watts, increasing system total to 50 watts**

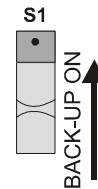

Switch S1 in
'Down'
position

4.75 K, 1 watt EOL
(Style Y Only)
Circuit is supervised
and power-limited

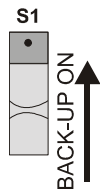

Switch S1 in
'Down'
position

Style Z

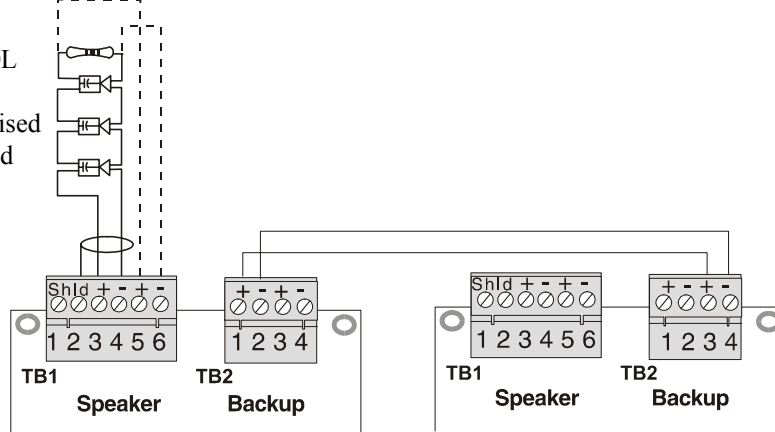

**First Amplifier
Mounted on Main Board**

**Optional Backup Amplifier
Mounted on Main Board**

**Second amplifier adds a Backup in the
event the primary amplifier fails**

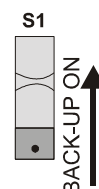

Switch S1 in
'Up'
(Backup)
position

Refer to ACC-25/50 Technical Manual Document #51889 for additional information on wiring.