

# Voice Evacuation Control Panel Main Circuit Board Replacement Product Installation Document

Document 51874 Rev A 10/10/01 ECN 01-507

*This Product Installation Document outlines the replacement of the Main Circuit Board for the Voice Evacuation Control Panel. Proper grounding, of the individual performing the replacement and the work area, is essential to prevent circuit board damage due to Electrostatic Discharge. Accepted industry practices must be employed.*

*Note: All hardware, (screws, nuts, standoffs, etc.) required to mount the main circuit board and option modules, is included in the main circuit board replacement kit, in the event any of the original hardware is misplaced during the circuit board removal and installation. This hardware is not required if the original hardware is removed from the old circuit board.*

**IMPORTANT!** Verify that the printed circuit boards and software revisions are the same as those shown in the following illustration, or higher.

**CAUTION!** Make certain all power (AC and DC) is removed before any replacement work is performed.

## Voice Evacuation Control Panel (VECP) Main Circuit Board Removal

Note that the following steps assume that all optional modules are installed. If one or more optional modules are not installed, skip the corresponding step(s) and proceed to the next step.

1. Make certain AC power has been turned off at the main service circuit breaker and the battery cable has been disconnected from connector P2 of the optional FC-PSM(E) Power Supply Module.
2. Disconnect the microphone cord by removing the plug from connector P6 on the main circuit board. Note the orientation of the plug prior to removal to ensure proper reconnection to the new circuit board.

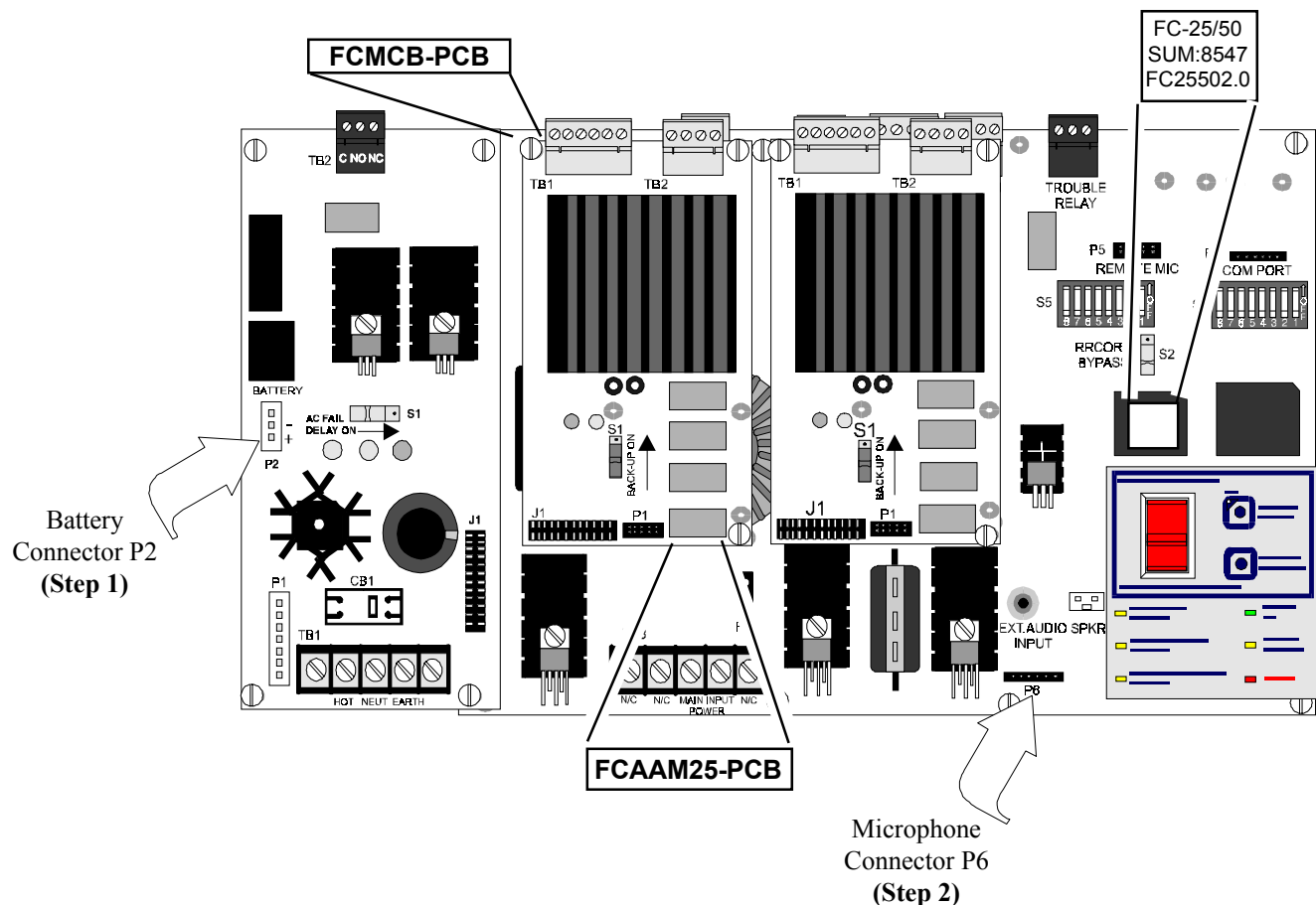

- Unplug the field wiring terminal block from connector TB2 of the optional FC-PSM(E) Power Supply Module. Remove and retain the four screws and washers from the corners of the optional module. Carefully unplug the FC-PSM(E) module from the main circuit board and place it in the bottom of the VECP cabinet. It is not necessary to disconnect the AC wiring (circuit breaker was turned off in Step 1) or transformer cable.

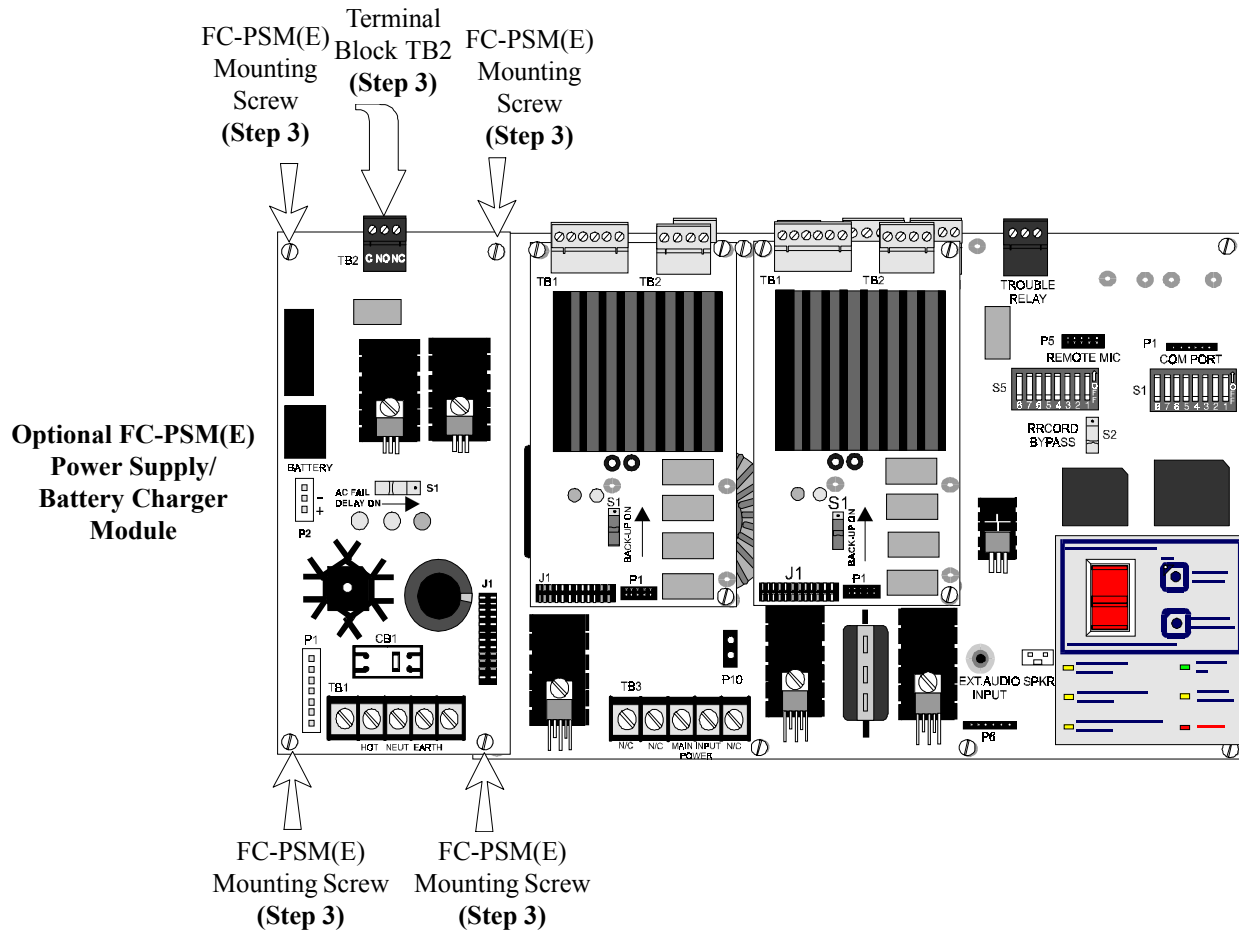

- Unplug the field wiring terminals from TB1 and TB2 of the standard FC-AAM25X Audio Amplifier Module which is plugged into connector P4 of the main circuit board. Do not remove this FC-AAM25X module at this time.
- Unplug the field wiring terminals from TB1 and TB2 of the optional second FC-AAM25X Audio Amplifier Module which is plugged into connector P3 in the center of the main circuit board. Remove and retain the screws and washers from the corners of the module. Carefully unplug the module from the main circuit board. Set module aside for installation on the new main circuit board.

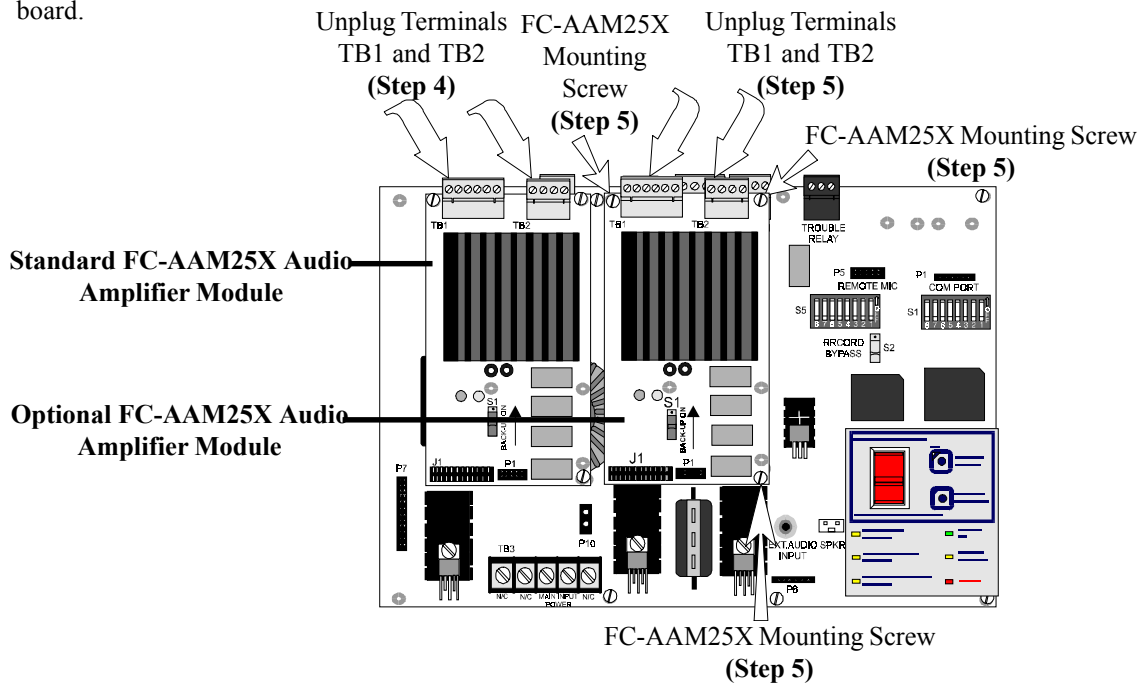

6. Remove three threaded metal standoffs from the main circuit board by grasping and rotating in a counterclockwise direction. Refer to the illustration below for the location of the three standoffs. Retain the standoffs for reinstallation on the new circuit board.

Notes:

- 1) If no option modules were previously installed, three screws will be removed instead of three standoffs
- 2) If only the optional FC-PSM(E) module was previously installed, two standoffs and one screw will be removed
- 3) If only the optional FC-AAM25X module was previously installed, one standoff and two screws will be removed

7. Remove the remaining mounting screws and washers from the main circuit board and retain for installation of the new circuit board. A total of eight (8) standoffs and/or screws are used to mount the main circuit board.

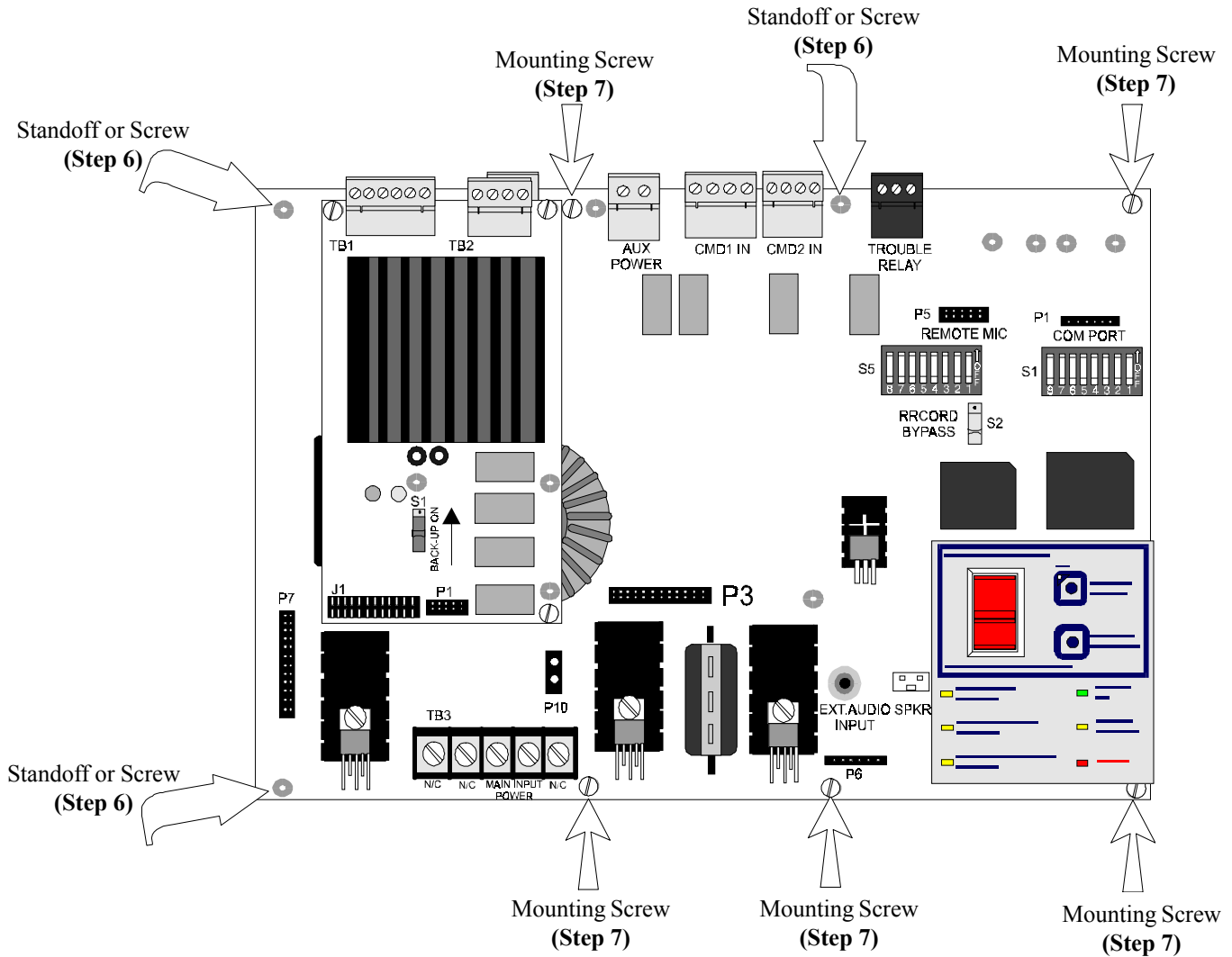

8. Remove the VECP main circuit board from the cabinet.
9. Remove the standard FC-AAM25X Audio Amplifier Module from the main circuit board by removing three screws and washers from the back of the main circuit board where the FC-AAM25X module is mounted. These screws secure the module standoffs to the main circuit board. Carefully unplug the module from the main circuit board and set aside for installation on the new main circuit board.
10. Remove the standoffs, which were used to secure the upper left and lower right corners of the optional FC-AAM25X module, from the main circuit board by removing the screws from the back of the VECP Main Circuit Board. Note that older Main Circuit Boards may have a plastic standoff in the lower right position. One of the metal standoffs, supplied with the replacement kit, should be installed on the new circuit board in place of the plastic standoff.

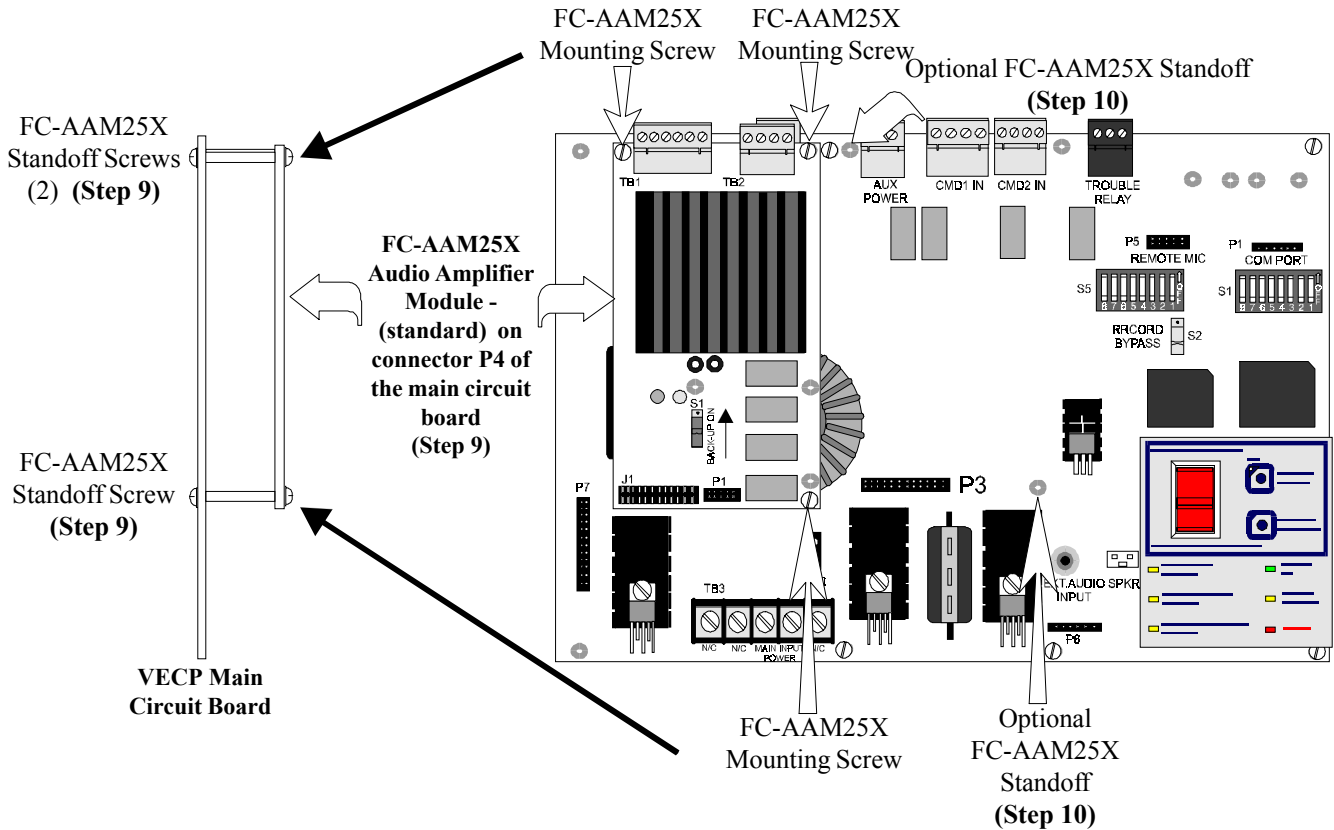

11. A metal standoff is attached to the back of the main circuit board and is used to support the circuit board against the backbox. The standoff is located near the Indicator/Switch Panel in the lower left corner of the main circuit board. Remove this standoff by turning counterclockwise and set aside for installation on the new circuit board. Note that this standoff with one male and one female end is slightly shorter (.937" length) than the other male/female standoffs (1" length). *Be certain to use the standoff just removed in the same position on the new circuit board.*

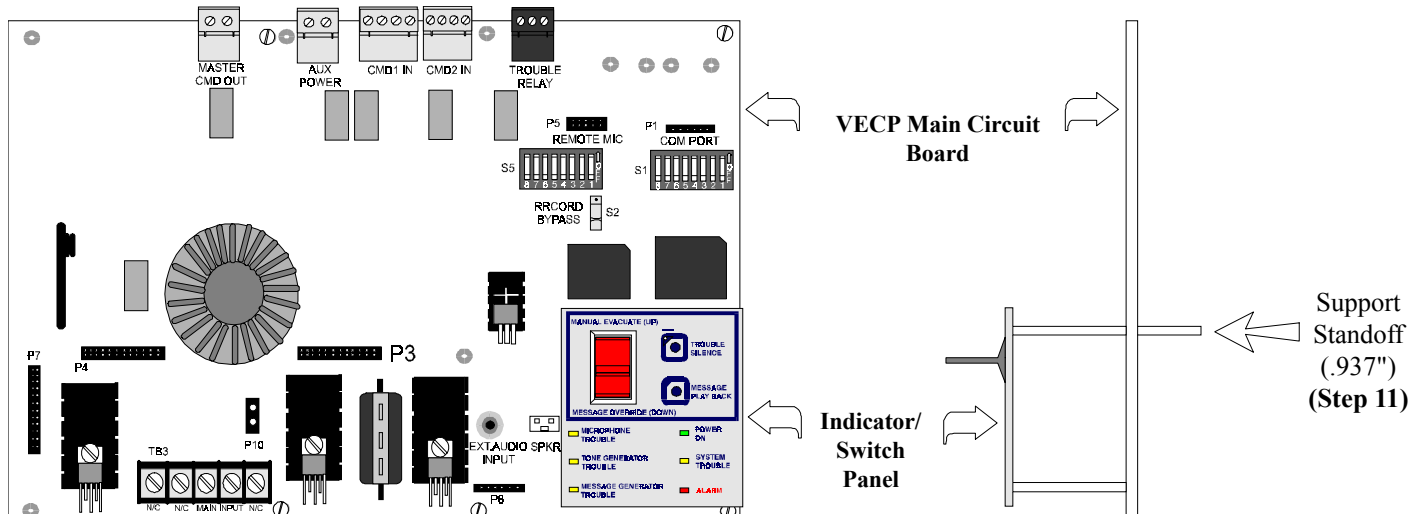

## Voice Evacuation Control Panel (VECP) Main Circuit Board Installation

Note that the following steps assume that all optional modules are to be reinstalled. If one or more optional modules are not reinstalled, skip the corresponding step(s) and proceed to the next step.

1. A screw is attached to the back of the new main circuit board and is used to hold one of the Indicator/Switch Panel's standoff in place during shipment. Remove and discard the screw and insert the metal standoff which was removed from the old main circuit board. Make certain to use the .937" length standoff removed in Step 11.

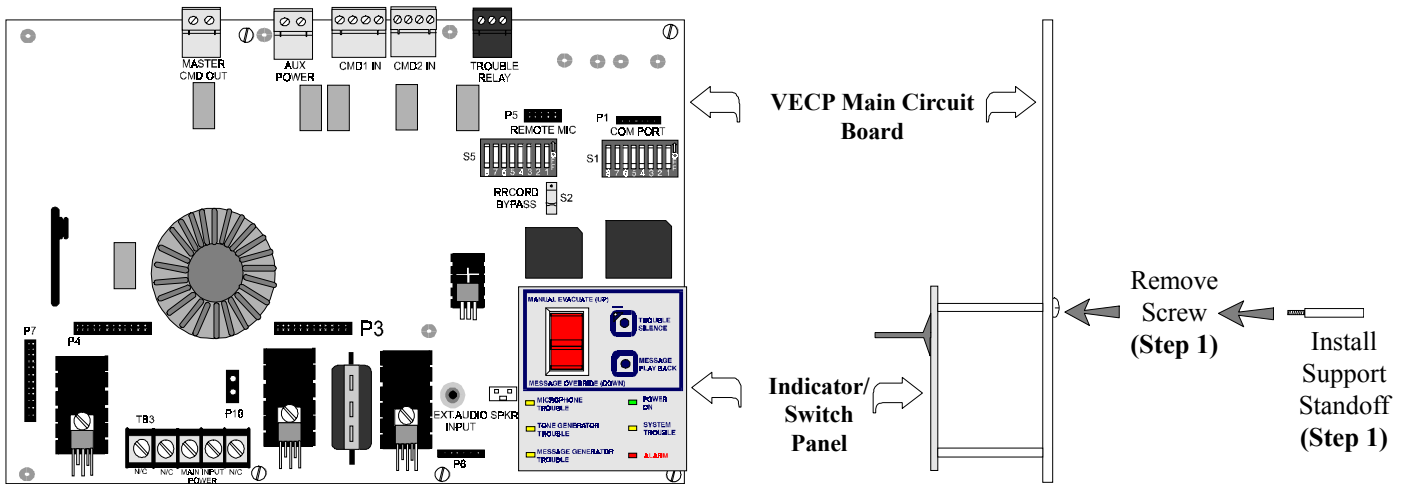

2. Install the standoffs, which are used to secure the upper left and lower right corners of the optional FC-AAM25X module, on the main circuit board by positioning the standoffs over the mounting holes and securing in place with screws through the back of the VECP Main Circuit Board. Note that if the older Main Circuit Board had a plastic standoff in the lower right position, replace it with a 1" metal standoff with two female ends, supplied with the kit. Secure the standoff with a supplied screw and washer.

*Note that if option modules are being reinstalled, there will be two different lengths of screws. The shorter screws are used to secure the main circuit board directly to the back box and the longer screws are used to attach standoffs to the main circuit board and option modules to the standoffs. Be certain to use the correct length screw.*

3. Install the standard FC-AAM25X Audio Amplifier Module on the main circuit board by carefully aligning connector P4 on the main circuit board with J1 on the FC-AAM25X and pressing into place, being careful not to bend any pins. Secure the FC-AAM25X standoffs to the main circuit board with three screws inserted through the back of the main circuit board.

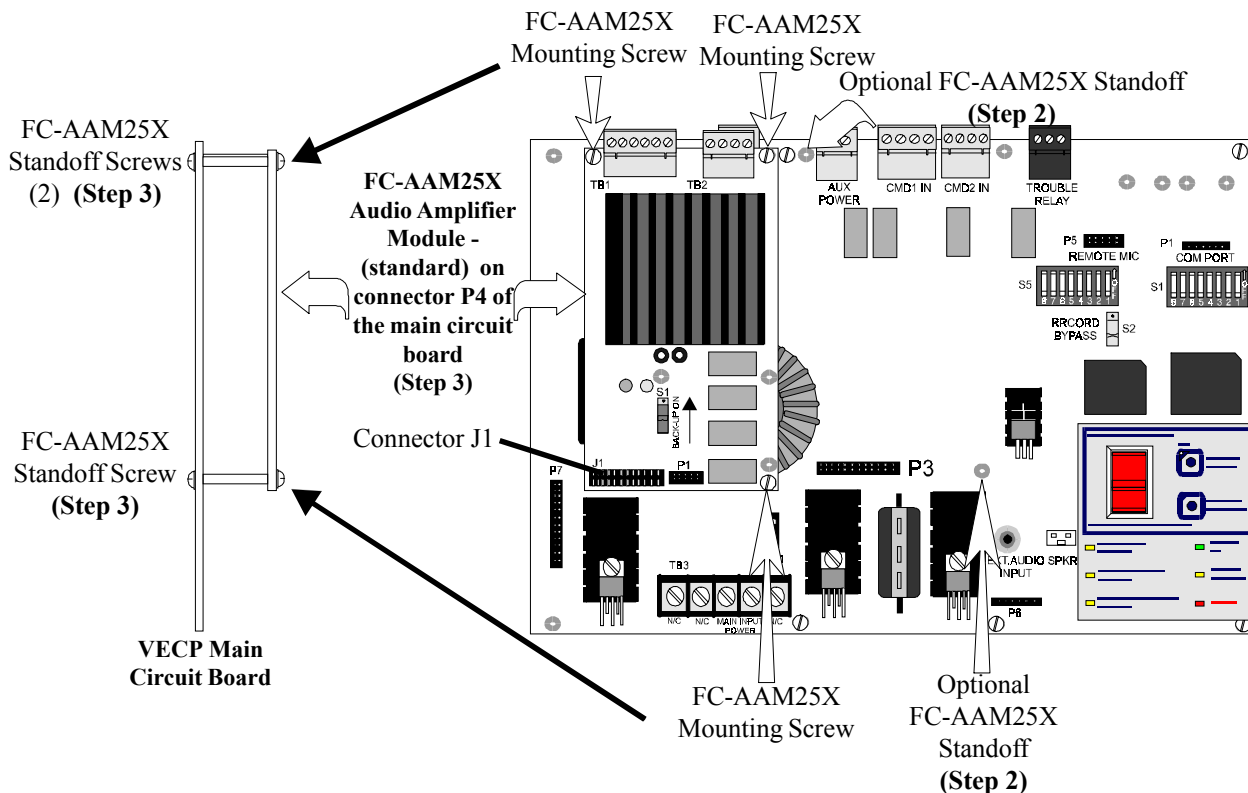

4. Position the VECP main circuit board in the cabinet so the mounting holes line up with the mounting studs on the cabinet rails.
5. Install three threaded metal standoffs in the main circuit board by grasping and rotating in a clockwise direction. Refer to the illustration below for the location of the standoffs.

Notes:

- 1) If no option modules are being installed, three screws will be installed instead of three standoffs
- 2) If only the optional FC-PSM(E) module is being reinstalled, two standoffs and one screw will be installed
- 3) If only the optional FC-AAM25X module is being reinstalled, one standoff and two screws will be installed

6. Finish securing the main circuit board to the backbox by installing the mounting screws and washers in the positions indicated in the illustration below.

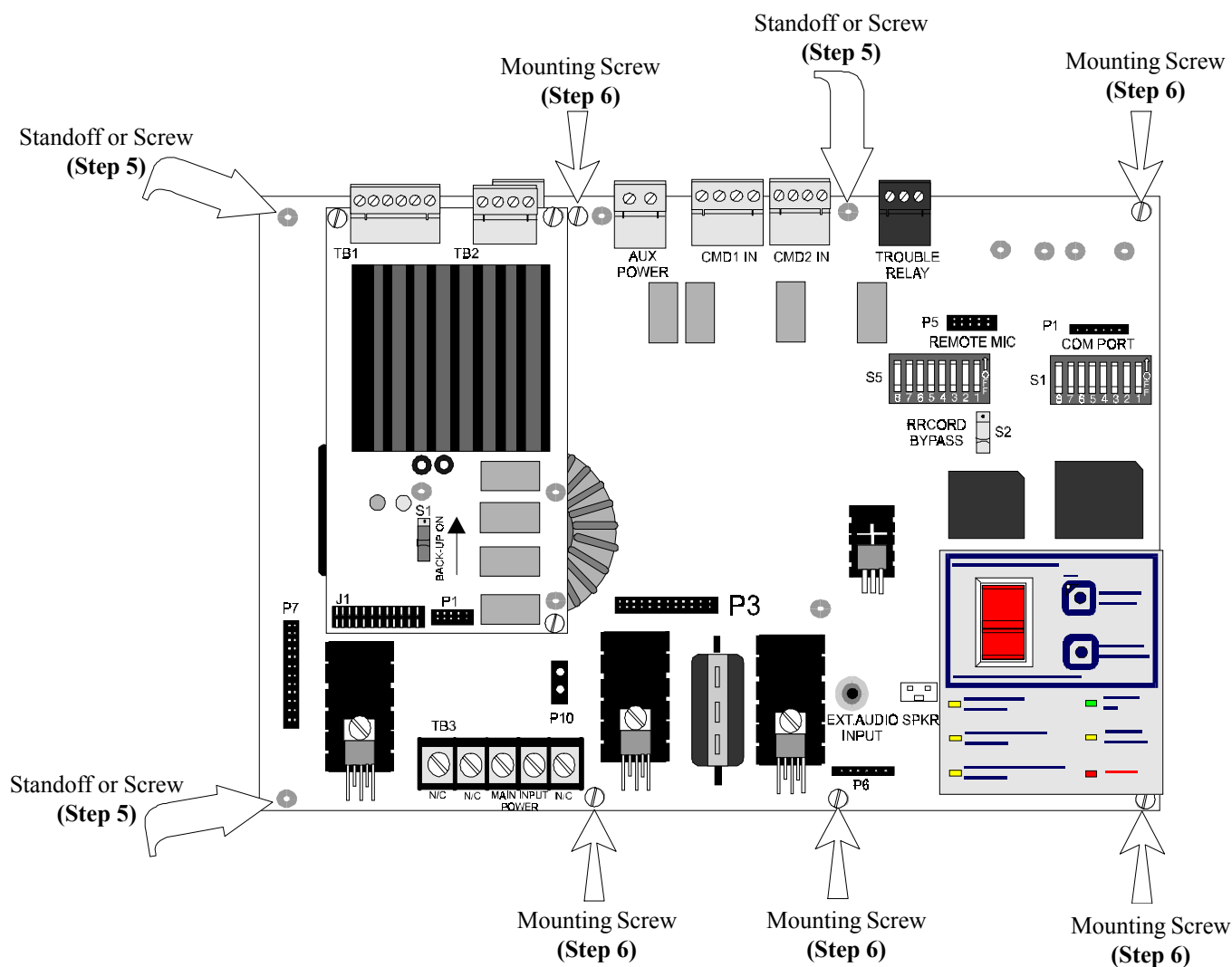

7. Install the optional FC-AAM25X module by carefully aligning connector P3 on the main circuit board with connector J1 on the FC-AAM25X module and pressing the module into place making certain not to bend any pins on the connector. Secure the module into place by inserting screws and washers in the positions indicated in the illustration below. Plug the field wiring terminals into TB1 and TB2 of the FC-AAM25X.
8. Plug the field wiring terminals into TB1 and TB2 of the standard FC-AAM25X Audio Amplifier Module which is plugged into connector P4 of the main circuit board.

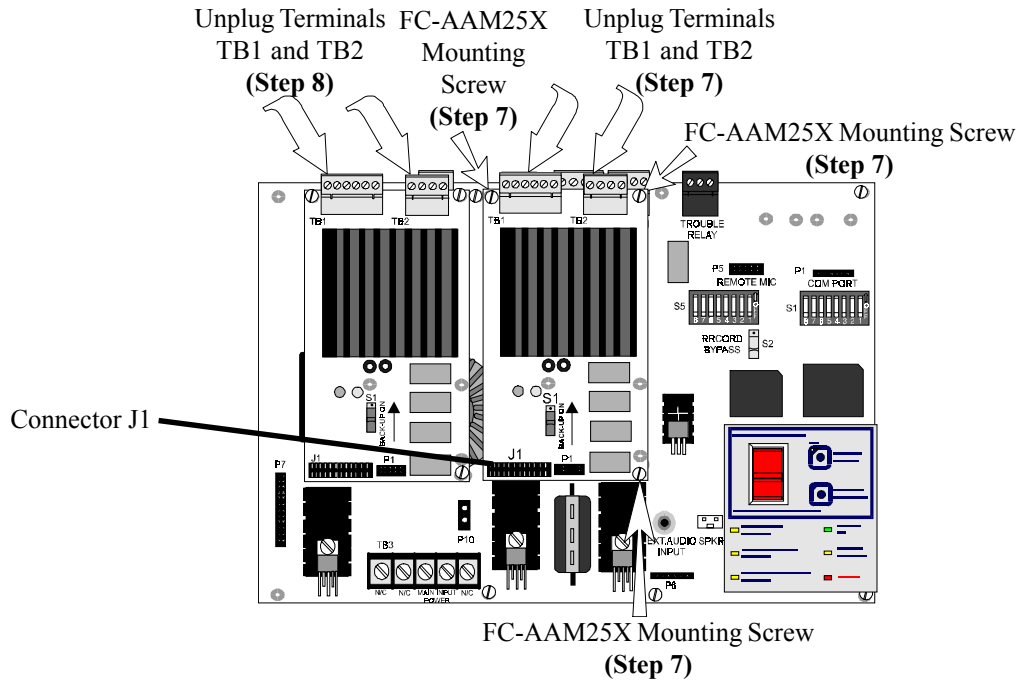

9. Install the FC-PSM(E) module by carefully aligning connector P7 on the main circuit board with connector J1 on the FC-PSM(E) module and pressing the module into place. Secure the FC-PSM(E) to the four standoffs with screws and washers which were previously removed. Plug the field wiring terminal block into connector TB2 of the optional FC-PSM(E) Power Supply Module.

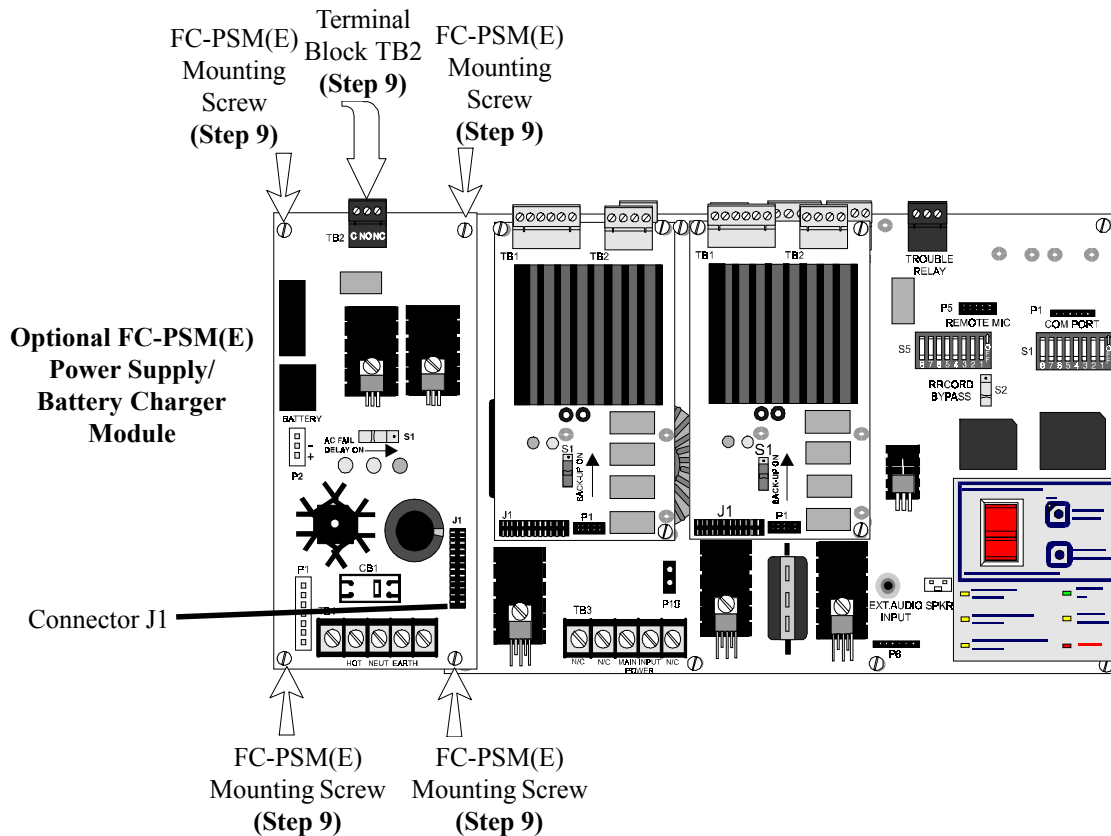

10. Reconnect the microphone cord plug to connector P6 on the main circuit board. Note the orientation of the plug to ensure proper reconnection to the new circuit board.
11. After confirming that all connections have been properly made, reapply AC power to the VECP and reconnect the battery cable to connector P2 of the optional FC-PSM(E) Power Supply Module.
12. Test the Voice Evacuation Control Panel completely to ensure proper operation.

