



Remote Fire Annunciator LCD-80F

Fire Alarm System Limitations

An automatic fire alarm system—typically made up of smoke detectors, heat detectors, manual pull stations, audible warning devices, and a fire alarm control with remote notification capability—can provide early warning of a developing fire. Such a system, however, does not assure protection against property damage or loss of life resulting from a fire.

The Manufacturer recommends that smoke and/or heat detectors be located throughout a protected premise following the recommendations of the current edition of the National Fire Protection Association Standard 72 (NFPA 72), manufacturer's recommendations, State and local codes, and the recommendations contained in the Guide for Proper Use of System Smoke Detectors, which is made available at no charge to all installing dealers. A study by the Federal Emergency Management Agency (an agency of the United States government) indicated that smoke detectors may not go off in as many as 35% of all fires. While fire alarm systems are designed to provide early warning against fire, they do not guarantee warning or protection against fire. A fire alarm system may not provide timely or adequate warning, or simply may not function, for a variety of reasons:

Smoke detectors may not sense fire where smoke cannot reach the detectors such as in chimneys, in or behind walls, on roofs, or on the other side of closed doors. Smoke detectors also may not sense a fire on another level or floor of a building. A second-floor detector, for example, may not sense a first-floor or basement fire.

Particles of combustion or "smoke" from a developing fire may not reach the sensing chambers of smoke detectors because:

- Barriers such as closed or partially closed doors, walls, or chimneys may inhibit particle or smoke flow.
- Smoke particles may become "cold," stratify, and not reach the ceiling or upper walls where detectors are located.
- Smoke particles may be blown away from detectors by air outlets.
- Smoke detectors may be drawn into air returns before reaching the detector.

The amount of "smoke" present may be insufficient to alarm smoke detectors. Smoke detectors are designed to alarm at various levels of smoke density. If such density levels are not created by a developing fire at the location of detectors, the detectors will not go into alarm.

Smoke detectors, even when working properly, have sensing limitations. Detectors that have photoelectronic sensing chambers tend to detect smoldering fires better than flaming fires, which have little visible smoke. Detectors that have ionizing-type sensing chambers tend to detect fast-flaming fires better than smoldering fires. Because fires develop in different ways and are often unpredictable in their growth, neither type of detector is necessarily best and a given type of detector may not provide adequate warning of a fire.

Smoke detectors cannot be expected to provide adequate warning of fires caused by arson, children playing with matches (especially in bedrooms), smoking in bed, and violent explosions (caused by escaping gas, improper storage of flammable materials, etc.).

While a fire alarm system may lower insurance rates, it is not a substitute for fire insurance!

Heat detectors do not sense particles of combustion and alarm only when heat on their sensors increases at a predetermined rate or reaches a predetermined level. Rate-of-rise heat detectors may be subject to reduced sensitivity over time. For this reason, the rate-of-rise feature of each detector should be tested at least once per year by a qualified fire protection specialist. *Heat detectors are designed to protect property, not life.*

IMPORTANT! Smoke detectors must be installed in the same room as the control panel and in rooms used by the system for the connection of alarm transmission wiring, communications, signaling, and/or power. If detectors are not so located, a developing fire may damage the alarm system, crippling its ability to report a fire.

Audible warning devices such as bells may not alert people if these devices are located on the other side of closed or partly open doors or are located on another floor of a building. Any warning device may fail to alert people with a disability or those who have recently consumed drugs, alcohol or medication. Please note that:

- Strobes can, under certain circumstances, cause seizures in people with conditions such as epilepsy.
- Studies have shown that certain people, even when they hear a fire alarm signal, do not respond or comprehend the meaning of the signal. It is the property owner's responsibility to conduct fire drills and other training exercise to make people aware of fire alarm signals and instruct them on the proper reaction to alarm signals.
- In rare instances, the sounding of a warning device can cause temporary or permanent hearing loss.

A fire alarm system will not operate without any electrical power. If AC power fails, the system will operate from standby batteries only for a specified time and only if the batteries have been properly maintained and replaced regularly.

Equipment used in the system may not be technically compatible with the control. It is essential to use only equipment listed for service with your control panel.

Telephone lines needed to transmit alarm signals from a premise to a central monitoring station may be out of service or temporarily disabled. For added protection against telephone line failure, backup radio transmission systems are recommended.

The most common cause of fire alarm malfunction is inadequate maintenance. To keep the entire fire alarm system in excellent working order, ongoing maintenance is required per the manufacturer's recommendations, and UL and NFPA standards. At a minimum, the requirements of Chapter 7 of NFPA 72 shall be followed. Environments with large amounts of dust, dirt or high air velocity require more frequent maintenance. A maintenance agreement should be arranged through the local manufacturer's representative. Maintenance should be scheduled monthly or as required by National and/or local fire codes and should be performed by authorized professional fire alarm installers only. Adequate written records of all inspections should be kept.

Installation Precautions

WARNING - Several different sources of power can be connected to the fire alarm control panel. Disconnect all sources of power before servicing. Control unit and associated equipment may be damaged by removing and/or inserting cards, modules, or interconnecting cables while the unit is energized. Do not attempt to install, service, or operate this unit until this manual is read and understood.

CAUTION - *System Reacceptance Test after Software Changes.* To ensure proper system operation, this product must be tested in accordance with NFPA 72 Chapter 7 after any programming operation or change in site-specific software. Reacceptance testing is required after any change, addition or deletion of system components, or after any modification, repair or adjustment to system hardware or wiring.

All components, circuits, system operations, or software functions known to be affected by a change must be 100% tested. In addition, to ensure that other operations are not inadvertently affected, at least 10% of initiating devices that are not directly affected by the change, up to a maximum of 50 devices, must also be tested and proper system operation verified.

This system meets NFPA requirements for operation at 0-49° C/32-120° F and at a relative humidity of 85% RH (non-condensing) at 30° C/86° F. However, the useful life of the system's standby batteries and the electronic components may be adversely affected by extreme temperature ranges and humidity. Therefore, it is recommended that this system and all peripherals be installed in an environment with a nominal room temperature of 15-27° C/60-80° F.

Verify that wire sizes are adequate for all initiating and indicating device loops. Most devices cannot tolerate more than a 10% I.R. drop from the specified device voltage.

Adherence to the following will aid in problem-free installation with long-term reliability:

Like all solid state electronic devices, this system may operate erratically or can be damaged when subjected to lightning-induced transients. Although no system is completely immune from lightning transients and interferences, proper grounding will reduce susceptibility. *Overhead or outside aerial wiring is not recommended, due to an increased susceptibility to nearby lightning strikes.* Consult with the Technical Services Department if any problems are anticipated or encountered.

Disconnect AC power and batteries prior to removing or inserting circuit boards. Failure to do so can damage circuits.

Remove all electronic assemblies prior to any drilling, filing, reaming, or punching of the enclosure. When possible, make all cable entries from the sides or rear. Before making modifications, verify that they will not interfere with battery, transformer, and printed circuit board location.

Do not tighten screw terminals more than 9 in-lbs. Over-tightening may damage threads, resulting in reduced terminal contact pressure and difficulty with screw terminal removal.

Though designed to last many years, system components can fail at any time. This system contains static-sensitive components. Always ground yourself with a proper wrist strap before handling any circuits so that static charges are removed from the body. Use static-suppressive packaging to protect electronic assemblies removed from the unit.

Follow the instructions in the installation, operating, and programming manuals. These instructions must be followed to avoid damage to the control panel and associated equipment. FACP operation and reliability depend upon proper installation by authorized personnel.

FCC Warning

WARNING: This equipment generates, uses, and can radiate radio frequency energy and if not installed and used in accordance with the instruction manual, may cause interference to radio communications. It has been tested and found to comply with the limits for class A computing device pursuant to Subpart B of Part 15 of FCC Rules, which is designed to provide reasonable protection against such interference when operated in a commercial environment. Operation of this equipment in a residential area is likely to cause interference, in which case the user will be required to correct the interference at his own expense.

Canadian Requirements

This digital apparatus does not exceed the Class A limits for radiation noise emissions from digital apparatus set out in the Radio Interference Regulations of the Canadian Department of Communications.

Le présent appareil numérique n'émet pas de bruits radioélectriques dépassant les limites applicables aux appareils numériques de la classe A prescrites dans le Règlement sur le brouillage radioélectrique édicté par le ministère des Communications du Canada.

NOTES

Table of Contents

Section 1: LCD-80F Annunciator	6
1.1 Features of LCD-80F	7
1.2 Components & Wiring	8
1.3 SW1 DIP Switch Settings	10
1.4 Typical Configuration	13
Section 2: Operation	14
2.1 Display Patterns	14
2.2 Switch Functions	15
2.2.1 Key-switch	15
2.2.2 Acknowledge/Step	15
2.2.3 Silence	16
2.2.4 Drill: Hold 2 Sec.	16
2.2.5 Reset	16
2.3 LED Indicators	17
2.3.1 AC Power	17
2.3.2 Alarm	17
2.3.3 Supervisory	17
2.3.4 Trouble	17
2.3.5 Alarm Silenced	17
Section 3: Mounting	18
3.1 Annunciator Preparation	18
3.2 Semi-flush Mount Backbox	20
3.3 Surface Mount Backbox	22
Section 4: Electrical Connections	23
4.1 Power Connections	23
4.2 EIA-485 Connections	24
Section 5: EIA-485 Shield Termination	25
5.1 Shield Not in Conduit	26
5.2 Shield in Full Conduit	27

Section 1: *LCD-80F Annunciator*

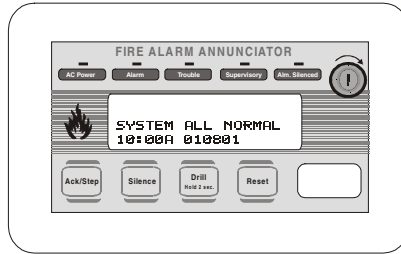

LCD-80F.cdr

The LCD-80F Annunciator is a compact, 80-character, backlit LCD fire annunciator designed for use with compatible FACP's (Fire Alarm Control Panel). *It should be noted that the LCD-80F Annunciator display will mimic the FACP display.*

The LCD-80F is capable of displaying English-language text of system point status including device type, independent *point* alarm, trouble or supervisory, zone and custom alpha labels programmed into the control panel. The LCD-80F also provides system status LEDs to display Power, Alarm, Trouble, Supervisory and Alarm Silenced conditions. The LCD-80F is capable of performing system acknowledge, silence, drill and reset remotely.

Communication between the FACP and the LCD-80F is accomplished over a two-wire serial interface employing the EIA-485 communication standard. Up to 32 annunciators may be connected to the two-wire EIA-485 circuit. The annunciators may be powered from the host FACP or remote UL listed, filtered, power supplies.

1.1 Features of LCD-80F

- 80-character LCD display (20 characters x 4 lines) is backlit under normal and alarm conditions
- System Status LEDs for AC Power (green), Alarm (red), Trouble (yellow), Supervisory (yellow) and Alarm Silenced (yellow)
- No programming necessary — duplicates messages at control panel display.
Note: The FACP may require programming to function with the LCD-80F. Refer to the specific FACP manual for programming information
- Local piezo sounder with alarm and trouble resound
- Device type identifiers from the control panel
- Device & zone custom alpha labels from the control panel
- Time/date and device address from the control panel
- EIA-485 connects to control panel terminal port
- Plug-in terminal blocks for ease of installation and service
- DIP switches control piezo enable/disable, transmit/receive mode, FACP selection, function switches and key-switch enable/disable.
- Up to 32 LCD-80F Annunciators per FACP
- Mounting options:
 - ✓ Surface mounting in SBB-3 (2.75" depth) or three electrical boxes ganged together
 - ✓ Semi-flush mounting in three-gang electrical box (P/N 10103) with a minimum depth of 2.187" or three electrical boxes ganged together
 - ✓ Can be located up to 6,000 feet (1,800 m) from the panel
- Backlight turns off during AC loss to conserve battery power but will turn back on if an alarm condition occurs.
- Enable/Disable key-switch
- Function switches for:
 - ✓ Acknowledge/Step
 - ✓ Alarm Silence
 - ✓ Drill
 - ✓ System Reset/Lamp Test

1.2 Components & Wiring

Figure 1-1: Components

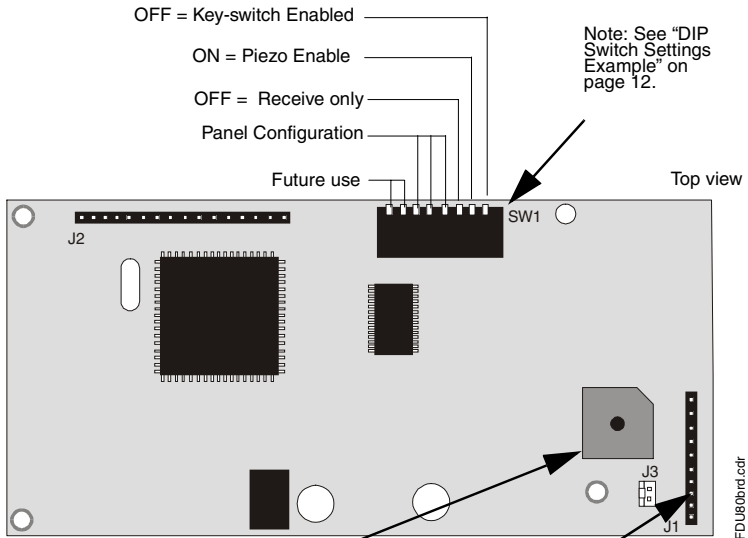

Piezo Sounder

The LCD-80F sounder, if enabled, will be activated when any new alarm or trouble is received from the panel. It is silenced by an Acknowledge switch. Piezo must not be disabled without approval of the LAHJ (Local Authority Having Jurisdiction).

Membrane Connector

Cable connection to membrane switches for Acknowledge, Silence, Drill and Reset.

Figure 1-2: Wiring to Terminals

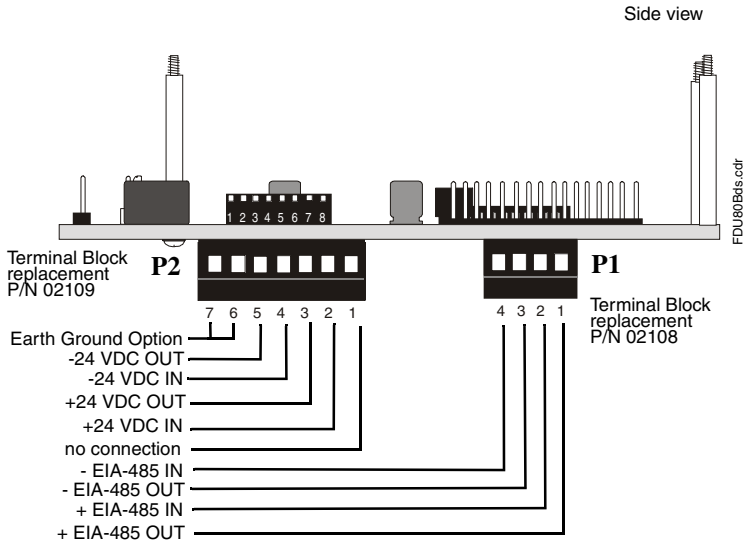

Note: These connections must be power-limited and the +24 VDC nominal power must be filtered and nonresettable.

Operating Voltage Range: 18 VDC to 28 VDC
Current Consumption @ 24 VDC nominal (filtered and nonresettable):
Normal/Standby (no activity): 64.3 mA
Trouble Condition: 64.3 mA
Alarm: 64.3 mA
AC Fail (not backlit): 25 mA

1.3 SW1 DIP Switch Settings

Refer to “DIP Switch Settings Example” on page 12, for an explanation of DIP switch positions. SW1 switch settings follow:

1 -On = Key-switch disabled, Off = Key-switch enabled.

Switch 1 set to the Off position enables key-switch operation. The key-switch may now be used to enable the LCD-80F membrane switches, allowing remote switch functions, or lockout the switches, preventing remote switch functions

Switch 1 set to the On position disables the key-switch operation. Refer to “Switch Functions” on page 15, for key-switch function description.

2 -On = Piezo sounder enabled, Off = Piezo sounder disabled.

CAUTION: *Piezo sounder must not be disabled without prior approval of the Local Authority Having Jurisdiction (LAHJ).*

3 -On = Supervision Receive/Transmit, Off = Supervision Receive Only.

- **One Annunciator** - if a single LCD-80F is the only annunciator connected to the EIA-485 loop, Switch 3 must be set to the ON position to allow the FACP to supervise the annunciator.
- **Multiple Annunciators** - if multiple LCD-80F annunciators are connected to the EIA-485 loop, the annunciator physically connected as the last device on the loop (farthest from the ‘OUT’ terminals on the FACP) must have Switch 3 set to the ON position in order to supervise all annunciators on the loop. All remaining annunciators must have Switch 3 set to the OFF position for proper supervision and operation.

It is important to note that the function switches on all LCD-80F annunciators will operate regardless of the setting of Switch 3.

A break (open circuit) in the power or EIA-485 connections creates an LCD-80F Annunciator fault at the control panel. All annunciators before the break will continue to display information (*but the function switches on these LCD-80Fs will no longer operate*).

4 through 6 = Configuration for use with a particular FACP.

Switches 4, 5 and 6 are used to select the FACP (Fire Alarm Control Panel) which is being connected to the LCD-80F. Refer to the following table for the appropriate switch settings.

Fire Alarm Control Panel	SW1-4	SW1-5	SW1-6
Use This Setting	OFF	OFF	OFF
Future Use	OFF	OFF	ON
Future Use	OFF	ON	OFF
Future Use	OFF	ON	ON
Future Use	ON	ON	OFF
Future Use	ON	OFF	ON
Future Use	ON	ON	OFF
Future Use	ON	ON	ON

7 and 8 = Future use.

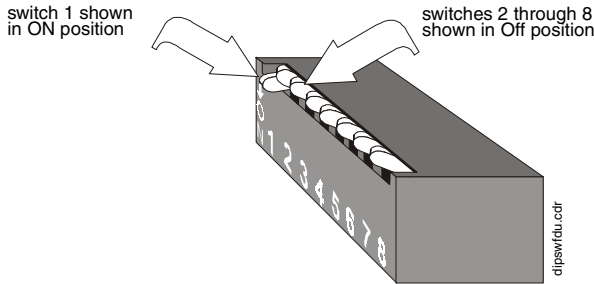
Figure 1-3: DIP Switch Settings Example

Note: SW1 DIP switch settings as illustrated in Figure 1-3 are as follows:

1. DIP switch 1: On = Key-switch disabled (membrane function switches are always enabled with key-switch having no affect on their function).
2. DIP switch 2: Off = piezo sounder disabled (requires approval of LAHJ)
3. DIP switch 3: Off = Receive Only. This setting is used for all annunciators except the last or only LCD-80F Annunciator on the EIA-485 line
4. DIP switches 4 through 6: Off = Configured correctly for operation with the available FACP
5. DIP switches 7 and 8: Off (these switches are not used)

1.4 Typical Configuration

The LCD-80F Annunciator mimics the FACP display, has full point-display capacity and requires no programming. *Note that the FACP may require programming to allow operation with the LCD-80F. Refer to the appropriate FACP manual for programming information.* The LCD-80F offers multiple annunciator locations with the capability of remote Acknowledge, Signal Silence, Drill and Reset functions.

Figure 1-4: Typical Configuration

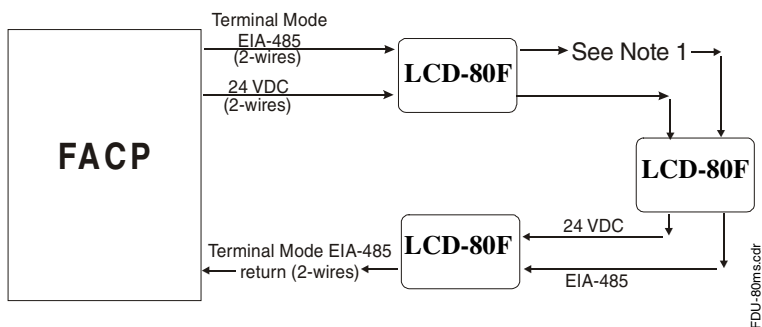

Notes:

1. 6,000 feet (1,800 m) maximum distance @ 18 AWG (0.75 mm²) between the FACP and the first LCD-80F, between each LCD-80F and from the last LCD-80F back to the FACP.
2. Up to 32 LCD-80F Annunciators may be used on the EIA-485 circuit. Refer to the specific FACP manual to determine the maximum current available for powering the LCD-80F. If additional annunciators are connected, the FCPS-24 may be used to supply additional power. Power supplies used for this purpose must have their negative terminals commoned together.
3. Between each LCD-80F annunciator are four wires - a twisted shielded pair for data communications and a pair for 24 VDC power. The return circuit only requires two wires for data communication supervision, wired from the last or only annunciator on the line.

Section 2: *Operation*

2.1 Display Patterns

The LCD-80F Annunciator directly displays (mimics) the information on the FACP display with the following exceptions:

- Upon Power-up, the LCD-80F may display the following message until a valid message is received from the FACP

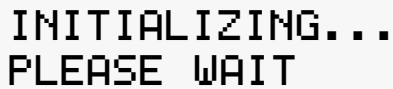

INITIALIZING...
PLEASE WAIT

- If an LCD-80F Annunciator fails to receive communications from the panel for a period of over 30 seconds, it will activate its local sounder (if so programmed) and display the following message:



COMMUNICATION FAULT!

2.2 Switch Functions

2.2.1 Key-switch

The key-switch is used to enable and disable the operation of the function switches if switch 1 on DIP switch SW1 has been placed in the Off position.

To enable the Acknowledge, Silence, Drill and Reset function switches, insert key into key-switch located at the top right corner of the LCD-80F. Make certain the key is inserted completely before attempting to turn it. Turn the key clockwise until it stops.

Leave the key inserted while pressing the function switches. When finished with the function switches, turn key-switch counterclockwise to disable function switches.

Note that the key-switch should normally be in the disabled position (fully counterclockwise), with the key removed and access to the key restricted to authorized personnel only. Do not leave the key unattended in the LCD-80F.

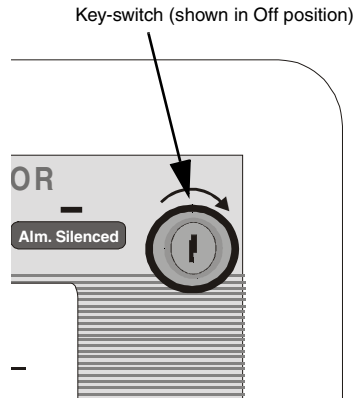

2.2.2 Acknowledge/Step

When the Acknowledge/Step switch is pressed and released, the LCD-80F sends an Acknowledge command to the control panel. Pressing the Acknowledge switch silences the local piezo sounder, the sounders located in all other system annunciators and the sounder located on the Fire Alarm Control Panel's main circuit board. Only one press is necessary regardless of the number of new alarms, troubles or supervisory signals.

An acknowledge message is also sent to the printer and the history files in the FACP. Multiple active events (alarms, troubles, supervisory) are scrolled on the display at a one second rate, but may be held for sequential display by pressing and holding the Acknowledge switch.

When more than one event exists, the first press of the Acknowledge switch silences system piezo sounders. The second press of the switch stops the scrolling and holds the event on the display for one minute. Subsequent pressing of the switch 'steps' through each active event.

2.2.3 Silence

When the Silence switch is pressed and released, the LCD-80F sends an alarm silence command to the control panel. The Silence switch performs the same functions as the Acknowledge switch. In addition, if an alarm exists, it turns off all silenceable NACs and causes the FACP Alarm Silenced LED to turn on while the LCD-80F will display a 'silenced' message. It also sends an 'Alarm Silenced' message to the printer and the history file within the FACP. A subsequent new alarm will resound the appropriate NACs (Notification Appliance Circuits) and local sounders.

2.2.4 Drill: Hold 2 Sec.

When the Drill switch is pressed and held for at least two seconds (time required to prevent accidental activations), the LCD-80F will transmit a drill command to the control panel. This command causes the FACP to turn on all NAC outputs and all silenceable circuits (all control modules/NACs that are programmed silenceable). In the event that the system was previously silenced, the drill command will also turn off the Alarm Silenced LED. The 'Manual Evacuate' message is shown on the LCD-80F display. The same message is sent to the FACP display, printer and history files. The Silence switch operates on *silenceable* NAC outputs only.

2.2.5 Reset

When the System Reset switch is pressed and released, the LCD-80F sends a Reset command to the control panel. This will turn off all control modules and Notification Appliance Circuits, temporarily turns off resettable power to 4-wire detectors, causes a 'System All Normal' message to be displayed on the LCD-80F and sends a 'System Reset' message to the FACP display, printer and FACP history files. It also turns on all system LEDs, piezo sounders and LCD display segments as long as the Reset switch is held (lamp test). Any alarm or trouble that exists after a Reset will resound the system.

2.3 LED Indicators

2.3.1 AC Power

This is a green LED which illuminates if AC power is applied to the host FACP. The green LED will turn off if AC power to the host FACP is lost.

2.3.2 Alarm

This is a red LED that turns on steady when one or more fire alarms occur. The Alarm LED turns off when the Reset switch is pressed.

2.3.3 Supervisory

This is a yellow LED that turns on steady when one or more supervisory conditions occur, such as a sprinkler valve tamper condition. It turns off when the Reset switch is pressed.

2.3.4 Trouble

This is a yellow LED that turns on steady when one or more trouble conditions occur. The LED turns off when all trouble conditions are cleared. This LED will also illuminate if the microprocessor watchdog circuit within the LCD-80F is activated.

2.3.5 Alarm Silenced

This is a yellow LED that turns on when the Silence switch is pressed to turn off the Notification Appliance Circuits. The LED turns off when the NACs turn back on or when the alarm condition is cleared and the FACP is reset back to a normal condition.

Section 3: *Mounting*

3.1 Annunciator Preparation

The LCD-80F Annunciator can be surface mounted in a three-gang electrical box such as the P/N SBB-3 (2.75" depth) or semi-flush mounted in a three-gang electrical box, P/N 10103 or equivalent, with a minimum depth of 2 3/16". The LCD-80F Annunciator can also be mounted in three gangable electrical switch boxes connected together. Select and remove the appropriate knockout(s), pull the necessary wires through the knockouts and mount the box in or on the wall depending on the type of installation desired. *Be certain that power is not applied to the wiring during the installation procedure.*

Note: To ensure static protection, all enclosures, including the LCD-80F electrical box, must be connected to earth ground! Never use the shield for grounding purposes.

To mount the LCD-80F Annunciator in an electrical box, the trim ring must first be removed. The trim ring is held in place by two screws inserted through the top and bottom edge as illustrated in Figure 3-1. Removal of the trim ring will expose a metal flange with mounting holes. Refer to "Hardware and Backboxes" on page 19.

Figure 3-1: Trim Ring Removal

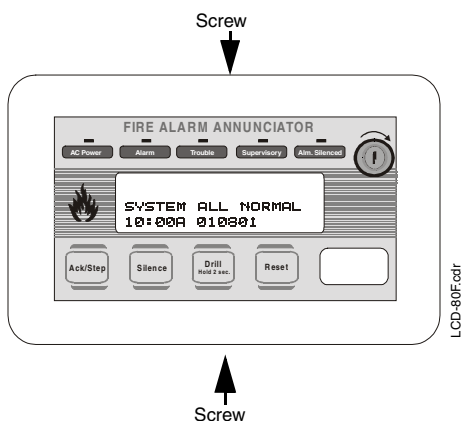
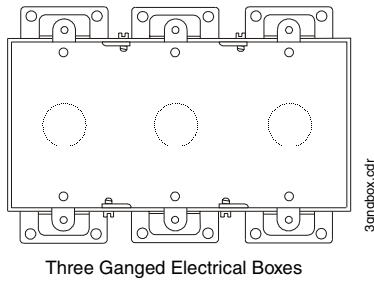
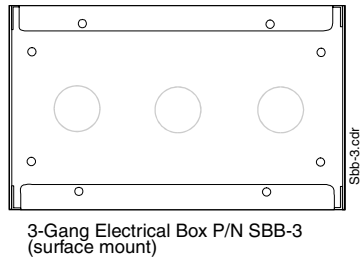
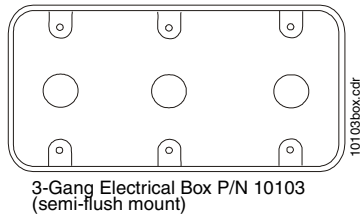
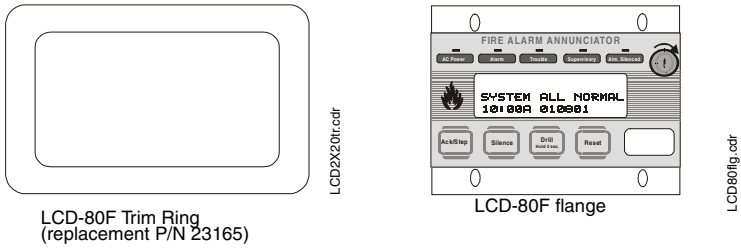

Figure 3-2: Hardware and Backboxes



3.2 Semi-flush Mount Backbox

Mounting in SBB-3 Three Gang Electrical Box

Remove the plug-in terminal blocks from the LCD-80F circuit board. Connect the EIA-485 and power wiring into the terminal block positions illustrated in Figure 1-2 on page 9, Figure 4-1 on page 23 and Figure 4-2 on page 24. Plug the terminal blocks back into the P2 and P1 connectors on the back of the annunciator. Set DIP switch SW1 for the desired options. Refer to Figure 1-3 on page 12.

Carefully insert the LCD-80F into the three-gang electrical box P/N: 10103 or three electrical boxes ganged together and attach it using the four mounting holes on the LCD-80F flange and the four screws provided for this purpose. Replace the trim ring and secure with the two screws which were previously loosened. Adjust the plastic trim ring to the surface of the wall before tightening the screws. *Do not overtighten.*

Figure 3-3: Mounting in SBB-3 Box

The LCD-80F can be semi-flush mounted in a three-gang electrical box, P/N 10103 or equivalent, with a minimum depth of 2 3/16". The LCD-80F can also be mounted in three gangable electrical switch boxes connected together as illustrated in Figure 3-4 on page 21.

Important! When installing conduit in a 3-gang electrical box, use knockouts on the top or bottom. Installing conduit on the sides or back of some boxes may interfere with mounting of the LCD-80F in the box.

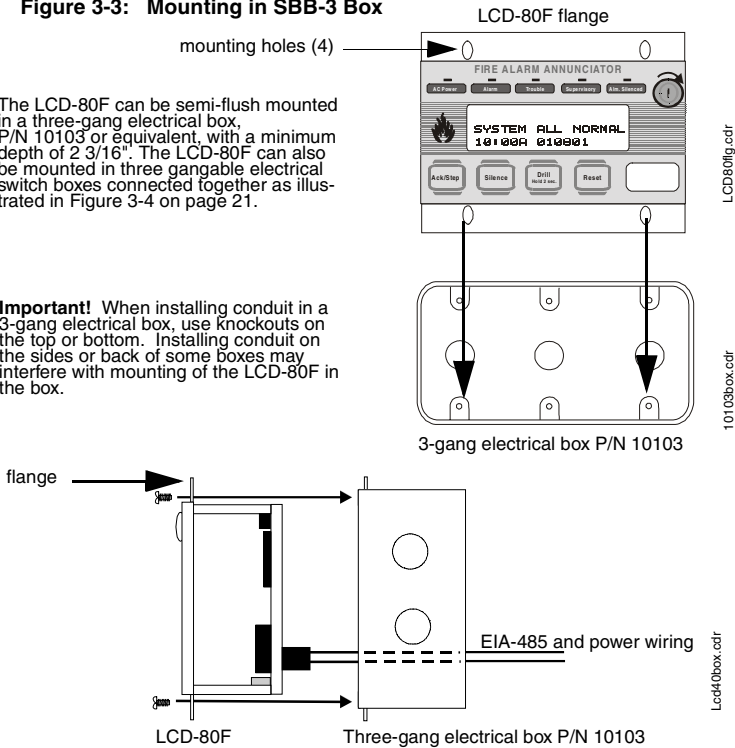

Mounting in Three Electrical Boxes Ganged Together

Remove the plug-in terminal blocks from the LCD-80F circuit board. Connect the EIA-485 and power wiring into the terminal block positions illustrated in Figure 1-2 on page 9, Figure 4-1 on page 23 and Figure 4-2 on page 24. Plug the terminal blocks back into the P2 and P1 connectors on the back of the annunciator. Set DIP switch SW1 for the desired options. Refer to Figure 1-3 on page 12.

Carefully insert the LCD-80F into the three electrical boxes ganged together and attach it using the four mounting holes on the LCD-80F flange and the four screws provided for this purpose. Replace the trim ring and secure with the two screws which were previously loosened. Adjust the plastic trim ring to the surface of the wall before tightening the screws. *Do not overtighten.*

Figure 3-4: Mounting in 3 Ganged Electrical Boxes

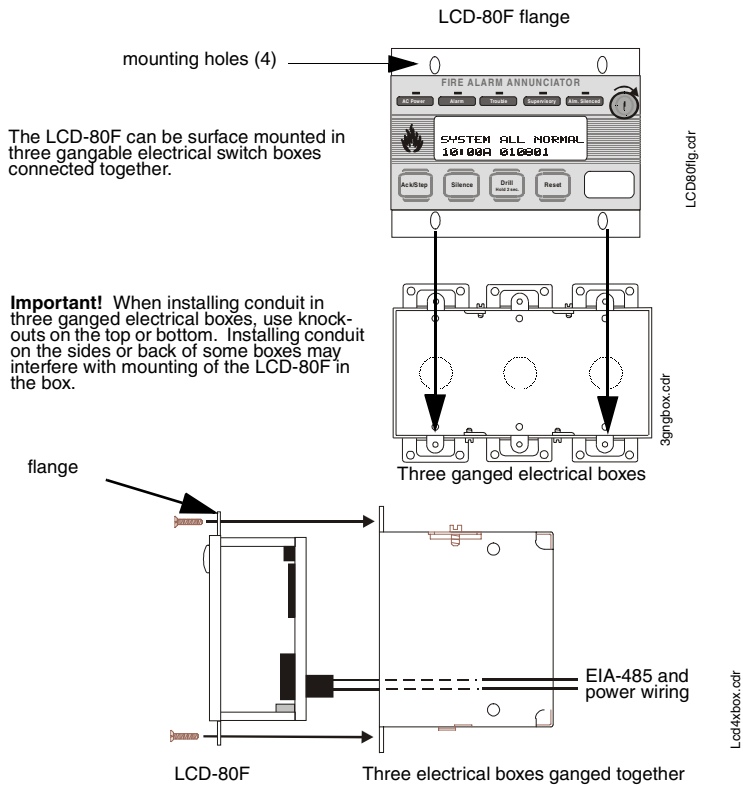

3.3 Surface Mount Backbox

Remove the plug-in terminal blocks from the LCD-80F circuit board. Connect the EIA-485 and power wiring into the terminal block positions illustrated in Figure 1-2 on page 9, Figure 4-1 on page 23 and Figure 4-2 on page 24. Plug the terminal blocks back into the P2 and P1 connectors on the back of the annunciator circuit board. Set DIP switch SW1 for the desired options. Refer to Figure 1-3 on page 12.

Carefully insert the LCD-80F into the three-gang electrical box and attach it using the four mounting holes on the LCD-80F flange and the four screws provided for this purpose. Replace the trim ring and secure with the two screws which were previously loosened. *Do not overtighten.*

Figure 3-5: Surface Mounting

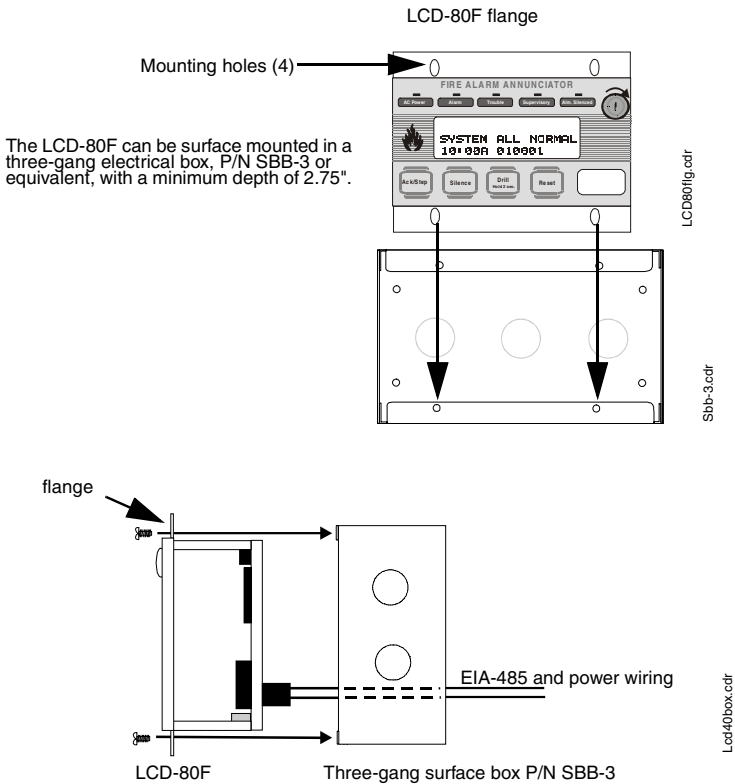

Section 4: *Electrical Connections*

4.1 Power Connections

The LCD-80F Annunciator can be powered by the FACP (refer to the specific technical manual for the proper connection of the LCD-80F) or from a remote UL listed, filtered power supply such as the FCPS-24F. The power run to the annunciator must be power-limited but need not contain a power supervision relay since loss of power is inherently supervised through loss of communication with the annunciator. Maximum LCD-80F current draw from the power supply (under normal and alarm conditions) is 64.3 mA. Maximum current draw from the control panel's secondary power source (batteries) under loss of AC power is 25 mA, since the LCD backlight is turned off during AC loss. Backlighting is turned back on during AC loss only for alarm conditions in the system.

Figure 4-1: Power Connection

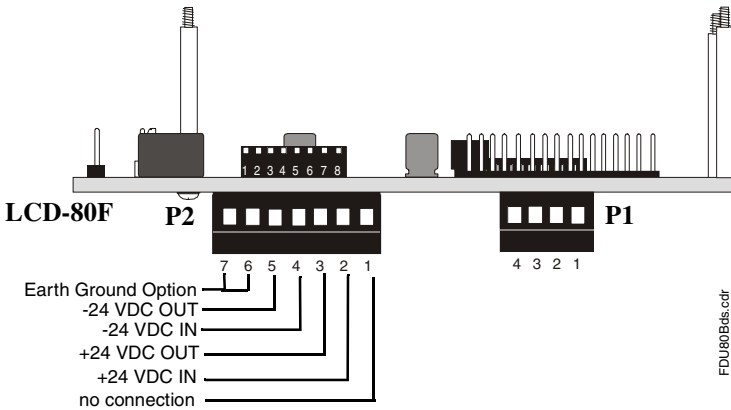

Notes:

1. All connections are power-limited and supervised
2. 12 - 18 AWG (0.75 - 3.25 mm²) wire for 24 VDC circuit is acceptable
3. Power wire distance limitation is set by 1.2 volt maximum line drop from source to end of circuit.

4.2 EIA-485 Connections

Figure 4-2: EIA-485 Connection

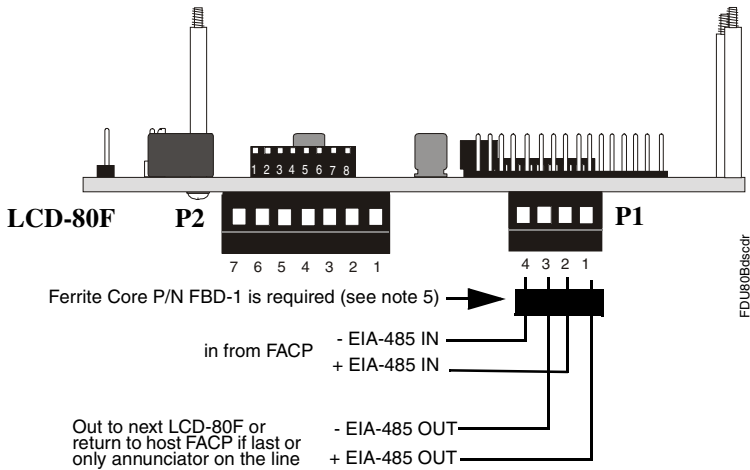

Notes:

1. All connections are power-limited and supervised
2. A maximum of 32 LCD-80F annunciators may be connected to this circuit
3. 6,000 feet (1,800 m) maximum distance @ 18 AWG (0.75 mm²) between the FACP and first LCD-80F, between each LCD-80F and return to the FACP from last LCD-80F
4. Use overall foil/braided-shielded twisted pair cable suitable for EIA-485 applications (refer to “EIA-485 Shield Termination” on page 25, for shield termination information). Six conductor overall shielded wire may be used for the four EIA-485 wires and the two power wires. It is, however, strongly recommended that the power and communication wires be separate whenever possible
5. Ferrite Core P/N FBD-1 is required to meet FCC Part 15 requirements if the EIA-485 wiring is not in conduit
6. The EIA-485 circuit is rated at 5.5 VDC maximum and 60 mA maximum
7. The LCD-80F annunciator has resistors built into the circuit board at the In (Terminals 2 & 4) and the Out (Terminals 1 & 3) for impedance matching. There is no need for the installer to add impedance matching resistors

Section 5: *EIA-485 Shield Termination*

The EIA-485 circuit must be wired using a twisted, shielded pair cable with a characteristic impedance of 120 ohms (+/- 20%). Do not run cable adjacent to or in the same conduit as 120 VAC service, noisy electrical circuits that are powering mechanical bells or horns, audio circuits above 25 V_{RMS}, motor control circuits or SCR power circuits.

Note: To ensure static (ESD - electrostatic discharge) protection, all enclosures, including the LCD-80F electrical box, must be connected to earth ground! Never use the EIA-485 shield for this purpose. The EIA-485 shield is for radiated noise emission protection (RFI, EMI). Refer to the following figures for details on EIA-485 shield termination.

5.1 Shield Not in Conduit

The EIA-485 line allows the FACP to communicate with the LCD-80F Annunciator. The shield for the EIA-485 line must be connected to earth ground at the FACP but must be left floating (no connection) at the annunciator if it is the first or only device on the EIA-485 line. If a second annunciator is connected, the shield leaving the first annunciator must be left floating. The shield entering the second annunciator must be connected to the three-gang box or Earth Ground terminal (P2-7) on the second annunciator. If additional annunciators are connected, the shield leaving each enclosure must be left floating and the shield entering each must be connected to the three-gang box or the Earth Ground terminal (P2-7) on the annunciator.

Figure 5-1: EIA-485 Without Conduit

Connect the drain wire to the outside of the FACP cabinet via a BX-type connector.

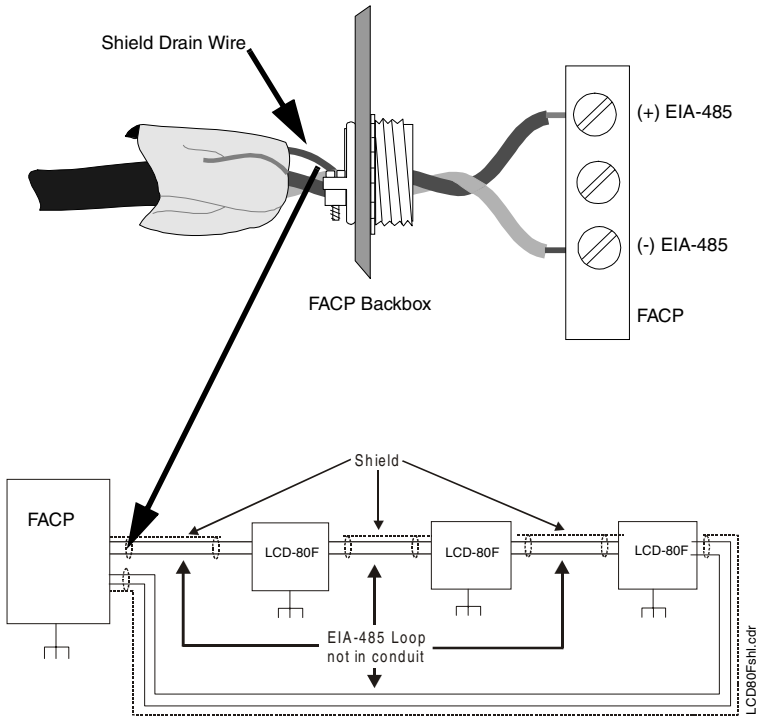

5.2 Shield in Full Conduit

The EIA-485 line allows the FACP to communicate with the LCD-80F Annunciator. The shield for the EIA-485 line must be connected to earth ground at the FACP (both exiting and entering the FACP) but must be left floating (no connection) at the annunciator if it is the first or only device on the EIA-485 line. If a second annunciator is connected, the shield leaving the first annunciator must be floating. The shield entering the second annunciator must be connected to the Earth Ground terminal (P2-7) on the second annunciator. If additional annunciators are connected, the shield leaving each annunciator must be left floating and the shield entering the following unit must be connected to the Earth Ground terminal (P2-7) on the annunciator.

Caution! Do not allow the floating shield end (no connection) to contact the conduit. The floating end should be insulated from earth ground.

Figure 5-2: EIA-485 In Conduit

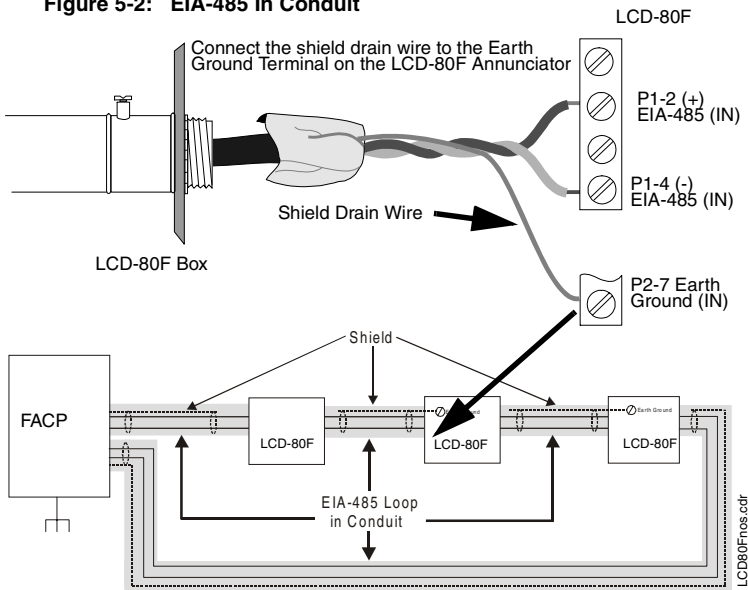

Notes:

1. Power-limited 24 VDC power may be run in the same conduit as the EIA-485 wiring
2. Twisted, shielded wire is recommended for the EIA-485 communications loop
3. Each electrical backbox is connected to earth ground via the conduit
4. Shield is connected to the FACP cabinet (earth ground) leaving and entering the FACP

NOTES

Index

Numerics

80-character 6, 7

A

AC loss 7

acknowledge switch 6, 15

Acknowledge/Step switch 7

 see also acknowledge switch 15

alarm LED 6, 7, 17

alarm silence switch 7

alarm silenced LED 6, 7, 16, 17

annunciator 6

annunciator, maximum 13

application

 see also typical configuration 13

B

backboxes 7, 18

backlit 6, 7

C

communication 6, 10

communication failure 14

components 8

configuration

 see also FACP selection 11

current specifications 9, 23

custom alpha labels 7

D

device type identifiers 7

DIP switch settings

 see also switch settings, example 12

DIP switches 7, 10

display information 6

display on powerup 14

distance, maximum 7, 13

drill switch 6, 7, 15, 16

E

earth ground 18

EIA-485 6, 7, 10, 13, 20, 22, 24, 27

 shield 25

EIA-485 wiring 24

electrical connections 23

enable/disable 7

 see also key-switch 10

F

FACP compatibility 6

FACP selection 11

FCC Part 15 requirements 24

ferrite core 24

flange 20, 22

function switches 7, 10

 see also switch functions 15

G

grounding 18, 25, 27

K

key-switch 10, 15

L

LAHJ 8, 10

LCD display 6, 7

 see also display on powerup 14

LED 7

 see also system status 6

LEDs 17

Local Authority Having Jurisdiction

 see also LAHJ 8

M

maximum annunciators 6, 7

mounting 18, 20, 21, 22

mounting options 7

O

operation 14

P

piezo sounder 7, 8, 10, 15

power for annunciator 6

power LED 6, 7, 17

power requirements 9, 13

power source 23

power-limited 9, 23

programming 7

R

receive only

 see also communication 10

receive/transmit

 see also communication 10

reset switch 6, 7, 15, 16

resound, piezo 7

S

SBB-3 backbox 18, 20

semi-flush mounting 20

shield

 no conduit 26

 see also EIA-485 25

silence switch 6, 15, 16

specifications 9

static protection 18, 25

supervision 10, 13, 23

supervisory LED 6, 7, 17

surface mounting 22

SW1 15

 see also DIP switches 10

switch functions 15

switch settings 10, 11

switch settings, example 12

system status 6, 7

T

terminal block 7, 9, 21, 22

three gang electrical boxes 18, 19

three ganged electrical boxes 21

trim ring 18, 19, 20, 21, 22

trouble LED 6, 7, 17

typical configuration 13

W

wiring 8, 9

 conduit 27

 distance 24

 EIA-485 24

 ferrite core 24

 no conduit 26

 power 23

 type 24

wiring requirements 13

NOTES

NOTES

Limited Warranty

The manufacturer warrants its products to be free from defects in materials and workmanship for eighteen (18) months from the date of manufacture, under normal use and service. Products are date-stamped at time of manufacture. The sole and exclusive obligation of the manufacturer is to repair or replace, at its option, free of charge for parts and labor, any part which is defective in materials or workmanship under normal use and service. For products not under the manufacturer's date-stamp control, the warranty is eighteen (18) months from date of original purchase by the manufacturer's distributor unless the installation instructions or catalog sets forth a shorter period, in which case the shorter period shall apply. This warranty is void if the product is altered, repaired, or serviced by anyone other than the manufacturer or its authorized distributors, or if there is a failure to maintain the products and systems in which they operate in a proper and workable manner. In case of defect, secure a Return Material Authorization form from our customer service department. Return product, transportation prepaid, to the manufacturer.

This writing constitutes the only warranty made by this manufacturer with respect to its products. The manufacturer does not represent that its products will prevent any loss by fire or otherwise, or that its products will in all cases provide the protection for which they are installed or intended. Buyer acknowledges that the manufacturer is not an insurer and assumes no risk for loss or damages or the cost of any inconvenience, transportation, damage, misuse, abuse, accident, or similar incident.

THE MANUFACTURER GIVES NO WARRANTY, EXPRESSED OR IMPLIED, OF MERCHANTABILITY, FITNESS FOR ANY PARTICULAR PURPOSE, OR OTHERWISE WHICH EXTEND BEYOND THE DESCRIPTION ON THE FACE HEREOF. UNDER NO CIRCUMSTANCES SHALL THE MANUFACTURER BE LIABLE FOR ANY LOSS OF OR DAMAGE TO PROPERTY, DIRECT, INCIDENTAL, OR CONSEQUENTIAL, ARISING OUT OF THE USE OF, OR INABILITY TO USE THE MANUFACTURER'S PRODUCTS. FURTHERMORE, THE MANUFACTURER SHALL NOT BE LIABLE FOR ANY PERSONAL INJURY OR DEATH WHICH MAY ARISE IN THE COURSE OF, OR AS A RESULT OF, PERSONAL, COMMERCIAL, OR INDUSTRIAL USE OF ITS PRODUCTS.

This warranty replaces all previous warranties and is the only warranty made by the manufacturer. No increase or alteration, written or verbal, of the obligation of this warranty is authorized.



FIRE-LITE® ALARMS

World Headquarters

One Fire-Lite Place, Northford, CT 06472-1653 USA

203-484-7161 • Fax 203-484-7118

www.firelite.com

ISO 9001
CERTIFIED
ENGINEERING & MANUFACTURING