

# FC-RMM

## Remote Microphone Module Product Installation Drawing

Document 51247 Revision B 10/01/01 ECN 01-115

The FC-RMM Remote Microphone Module, which is installed in a CAB-RMRF cabinet as illustrated in Figure 1, provides paging capabilities for audio systems such as the FC-25/50X and FC-25/50DA.

Following is a list of FC-RMM features:

- Automatic gain control circuit
- All wiring is power-limited
- Supervised microphone
- All external wiring is supervised
- Power On LED
- Trouble LED
- Pluggable terminal blocks
- Remote location for paging

### Power Specifications:

- 6 mA non-fire alarm current
- 30 mA when microphone is activated
- 24 VDC Nominal Operating Voltage

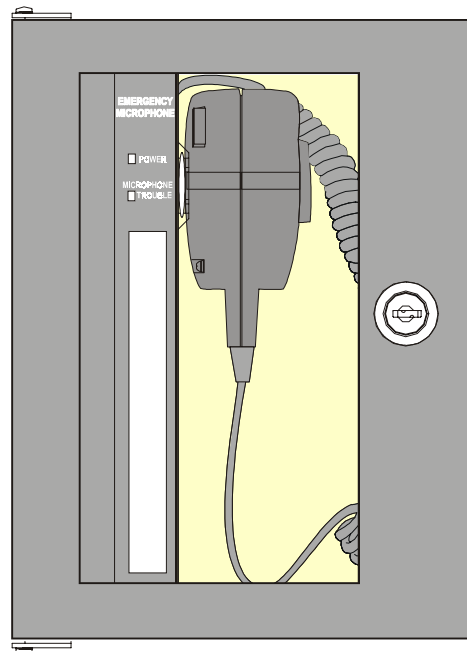

Figure 1: FC-RMM in a CAB-RMRF

## FC-MIM Microphone Interface Module Installation

The supplied FC-MIM Microphone Interface Module must be installed on the main circuit board of the host audio panel.

**CAUTION:** *Circuits contain static-sensitive components. Always ground yourself with a proper wrist strap before handling any circuits so that static charges are removed from the body. Use static suppressive packaging to protect electronic assemblies.*

To install the FC-MIM:

1. Be sure all power (AC and DC) is removed from the panel before installing the FC-MIM
2. Position the connector on the FC-MIM module over the audio panel main circuit board connector P5 and gently press down until the module is properly seated. Be careful not to bend or break any pins on the P5 connector
3. Secure the FC-MIM module to the metal standoff on the main circuit board with the supplied screw

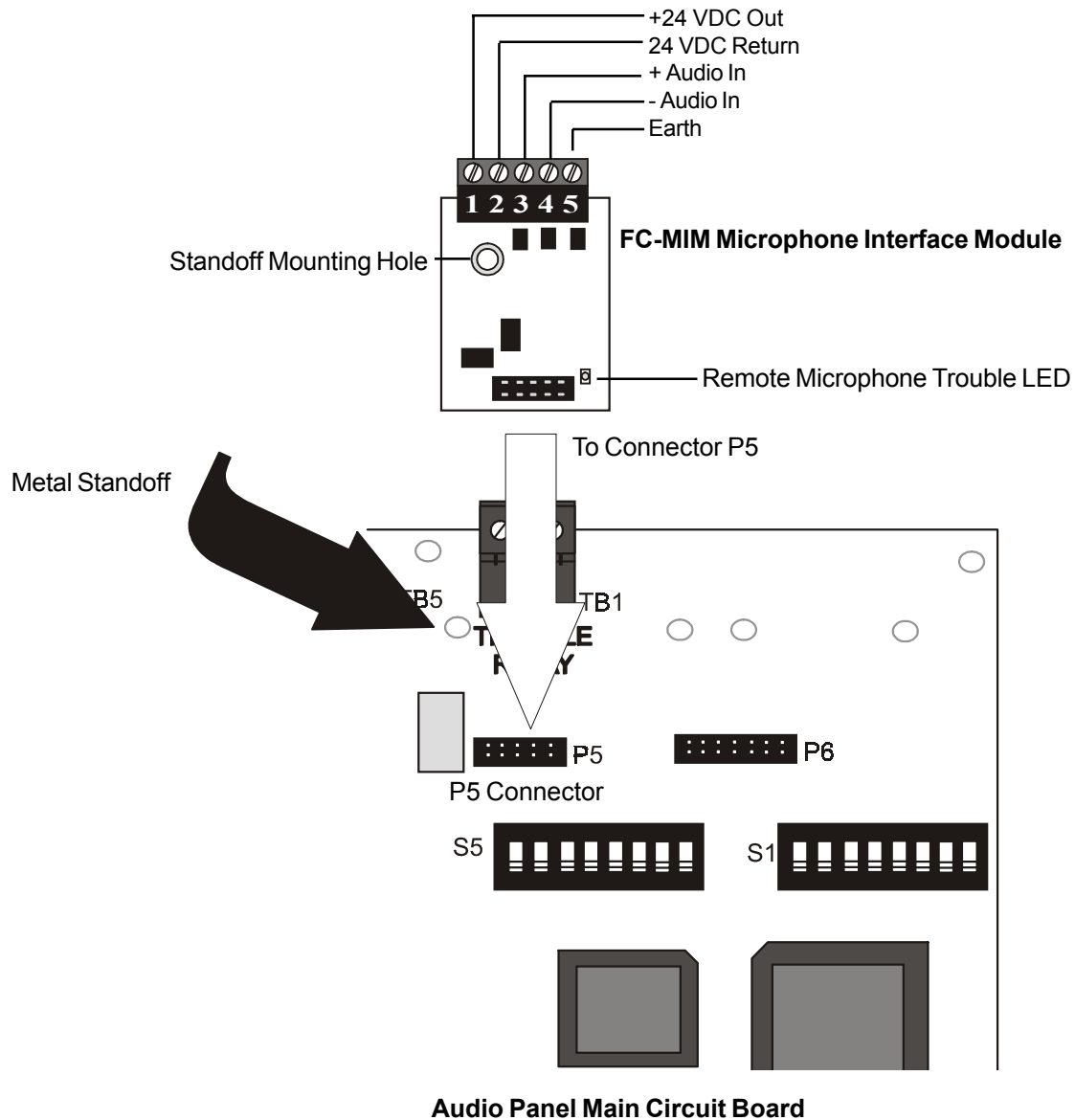

# Installation

## Slide-in Label

A slide-in label (part number 51146) is provided with each FC-RMM assembly. Enter the location of the microphone speakers on this label along with any instructions for speaker activation, then slide the label into the label slot at the bottom of the assembly. (See Figure 2).

## FC-RMM Installation to the CAB-RMRF Cabinet

**CAUTION:** Circuits contain static-sensitive components. Always ground yourself with a proper wrist strap before handling any circuits so that static charges are removed from the body. Use static suppressive packaging to protect electronic assemblies.

1. Be sure all power (AC and DC) is removed before installing the FC-RMM.
2. Pull the required wiring into the CAB-RMRF cabinet through the knockouts provided (refer to Figure 3).
3. Attach wiring to the pluggable terminal blocks and plug onto the FC-RMM board (refer to Figure 5)
4. Carefully slide the board into the cabinet until it rests in the slots on the back wall of the box (See Figure 4a).
5. Secure the FC-RMM in the cabinet with the two self-tapping screws provided (See Figure 4b).

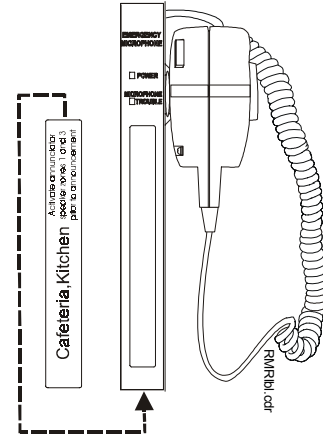

Figure 2: Slide-in Label

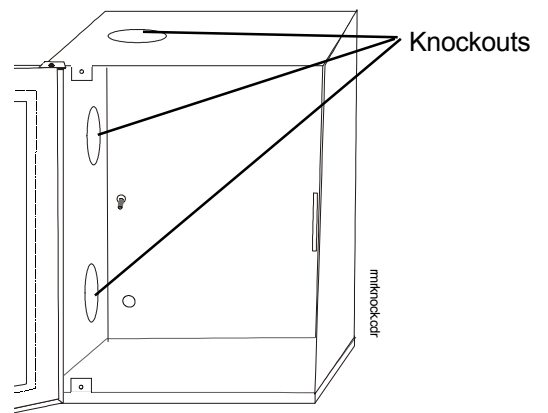

Figure 3: Knockout Locations

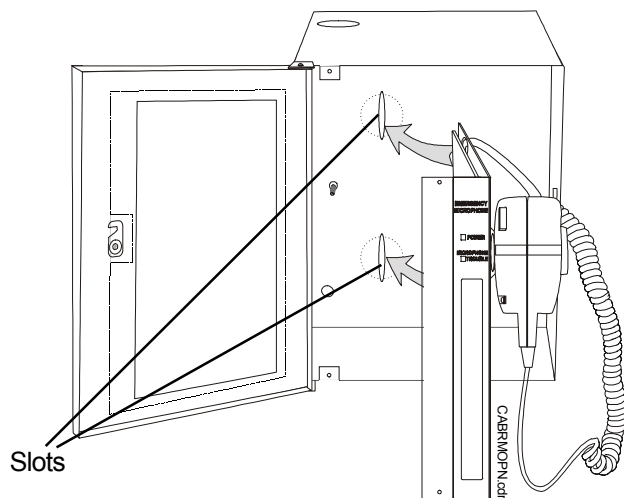

Figure 4a

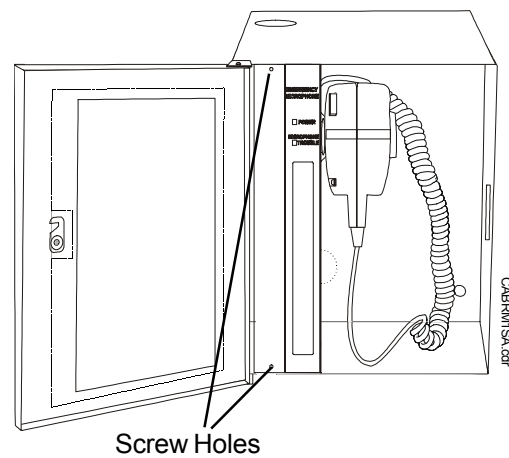
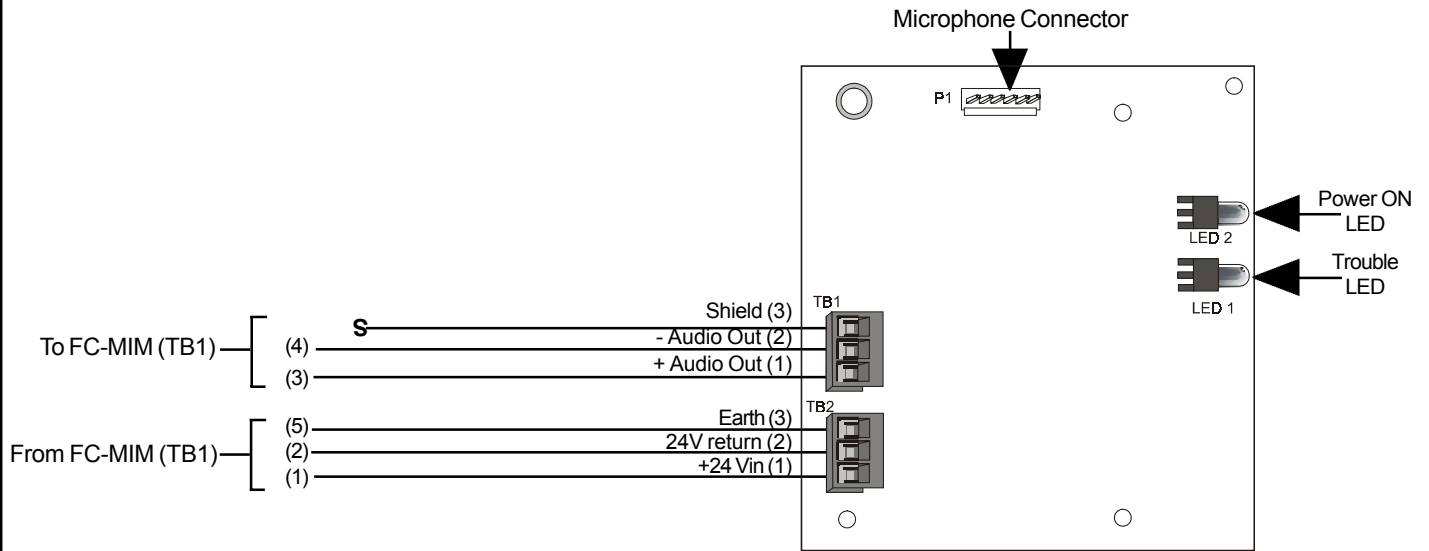

Figure 4b

Figure 4: Installing the FC-RMM

## Wiring the FC-RMM and FC-MIM



**Figure 5: FC-RMM Wiring**

### **TB1: FC-RMM OUTPUT**

The FC-RMM audio output terminals [TB1 Terminals 1 (+) and 2 (-)] provide a +6 to +7 VDC voltage audio level when activated by the microphone PTT (Push-To-Talk) switch. When the PTT is not activated, a +2 VDC voltage is present at the output of the FC-RMM. The output of the FC-RMM connects to the Microphone Interface Module located in the FC-25/50X or FC-25/50DA as illustrated in Figure 5.

### **TB2: INPUT POWER SUPPLY**

The FC-RMM is powered by the FC-25/50X or FC-25/50DA via the FC-MIM. The FC-MIM distributes +24 VDC to the FC-RMM. The FC-MIM also supplies Earth and analog grounds to the FC-RMM. Refer to Figure 5.

**LED 1** - This yellow LED will light when the FC-RMM microphone is disconnected.

**LED 2** - This green LED will light when the FC-RMM is powered.

The FC-RMM can be remotely connected to the FC-25/50X or FC-25/50DA with the FC-MIM. It can be connected up to 1,500 feet (450 m) with a negligible amount of noise and distortion. The wiring configuration is shown in Figure 6.

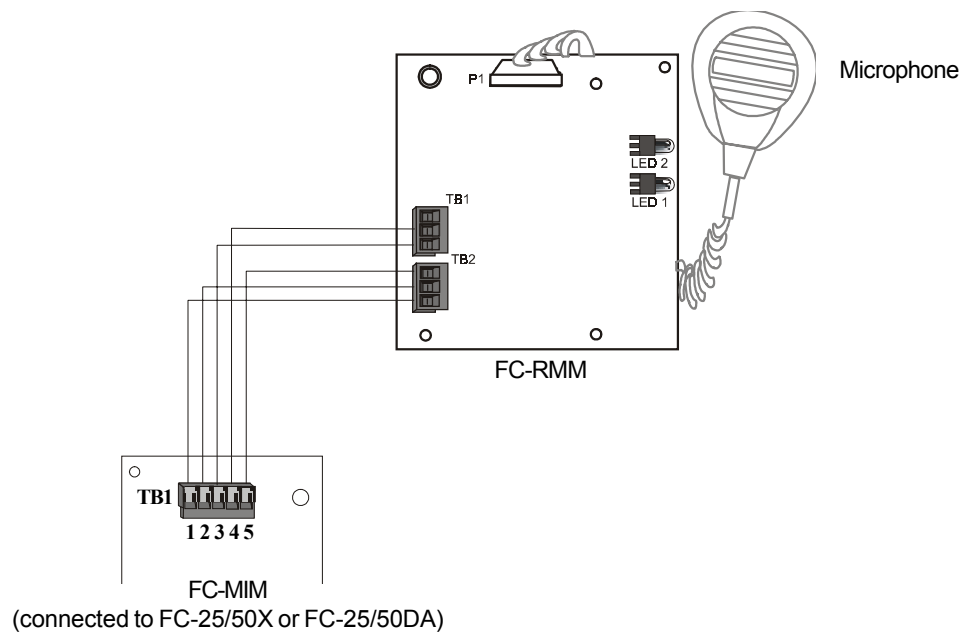

**Figure 6: FC-MIM Wiring**

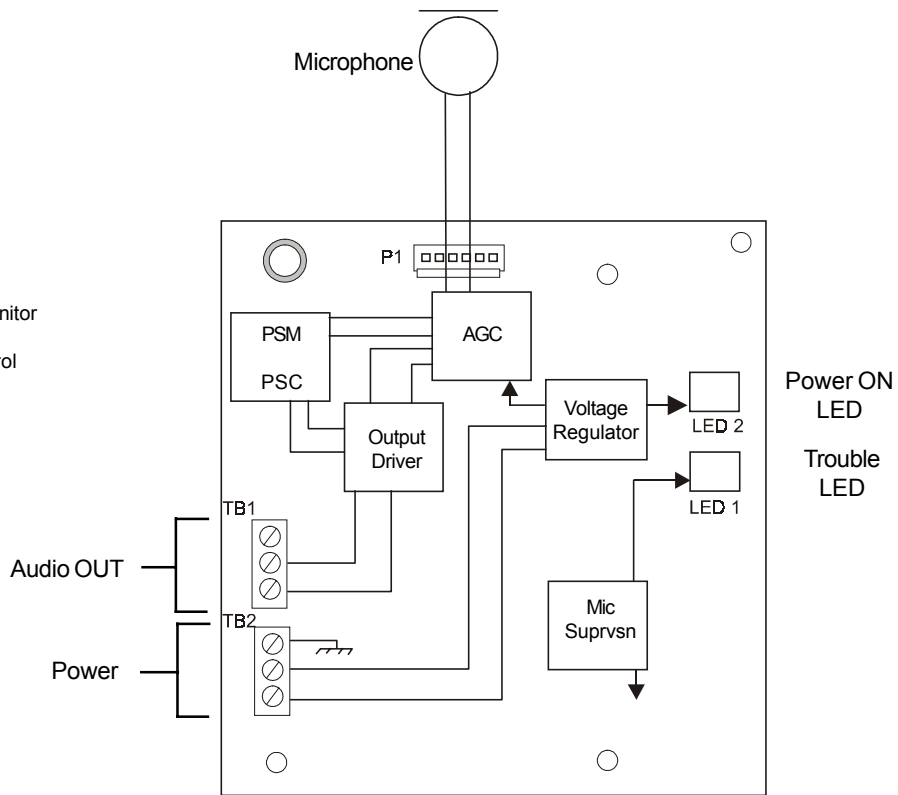

**PSM** - Push-To-Talk Switch Monitor  
**AGC** - Automatic Gain Control  
**PSC** - Power Save Circuit

**Figure 7: FC-RMM Block Diagram**