

Battery Charger
CHG-120F
Installation & Operating Manual

Document 50888

03/21/2001

Rev:

B

Fire Alarm System Limitations

An automatic fire alarm system—typically made up of smoke detectors, heat detectors, manual pull stations, audible warning devices, and a fire alarm control with remote notification capability—can provide early warning of a developing fire. Such a system, however, does not assure protection against property damage or loss of life resulting from a fire.

The Manufacturer recommends that smoke and/or heat detectors be located throughout a protected premise following the recommendations of the current edition of the National Fire Protection Association Standard 72 (NFPA 72), manufacturer's recommendations, State and local codes, and the recommendations contained in the Guide for Proper Use of System Smoke Detectors, which is made available at no charge to all installing dealers. A study by the Federal Emergency Management Agency (an agency of the United States government) indicated that smoke detectors may not go off in as many as 35% of all fires. While fire alarm systems are designed to provide early warning against fire, they do not guarantee warning or protection against fire. A fire alarm system may not provide timely or adequate warning, or simply may not function, for a variety of reasons:

Smoke detectors may not sense fire where smoke cannot reach the detectors such as in chimneys, in or behind walls, on roofs, or on the other side of closed doors. Smoke detectors also may not sense a fire on another level or floor of a building. A second-floor detector, for example, may not sense a first-floor or basement fire.

Particles of combustion or "smoke" from a developing fire may not reach the sensing chambers of smoke detectors because:

- Barriers such as closed or partially closed doors, walls, or chimneys may inhibit particle or smoke flow.
- Smoke particles may become "cold," stratify, and not reach the ceiling or upper walls where detectors are located.
- Smoke particles may be blown away from detectors by air outlets.
- Smoke detectors may be drawn into air returns before reaching the detector.

The amount of "smoke" present may be insufficient to alarm smoke detectors. Smoke detectors are designed to alarm at various levels of smoke density. If such density levels are not created by a developing fire at the location of detectors, the detectors will not go into alarm.

Smoke detectors, even when working properly, have sensing limitations. Detectors that have photoelectronic sensing chambers tend to detect smoldering fires better than flaming fires, which have little visible smoke. Detectors that have ionizing-type sensing chambers tend to detect fast-flaming fires better than smoldering fires. Because fires develop in different ways and are often unpredictable in their growth, neither type of detector is necessarily best and a given type of detector may not provide adequate warning of a fire.

Smoke detectors cannot be expected to provide adequate warning of fires caused by arson, children playing with matches (especially in bedrooms), smoking in bed, and violent explosions (caused by escaping gas, improper storage of flammable materials, etc.).

While a fire alarm system may lower insurance rates, it is not a substitute for fire insurance!

Heat detectors do not sense particles of combustion and alarm only when heat on their sensors increases at a predetermined rate or reaches a predetermined level. Rate-of-rise heat detectors may be subject to reduced sensitivity over time. For this reason, the rate-of-rise feature of each detector should be tested at least once per year by a qualified fire protection specialist. *Heat detectors are designed to protect property, not life.*

IMPORTANT! Smoke detectors must be installed in the same room as the control panel and in rooms used by the system for the connection of alarm transmission wiring, communications, signaling, and/or power. If detectors are not so located, a developing fire may damage the alarm system, crippling its ability to report a fire.

Audible warning devices such as bells may not alert people if these devices are located on the other side of closed or partly open doors or are located on another floor of a building. Any warning device may fail to alert people with a disability or those who have recently consumed drugs, alcohol or medication. Please note that:

- Strobes can, under certain circumstances, cause seizures in people with conditions such as epilepsy.
- Studies have shown that certain people, even when they hear a fire alarm signal, do not respond or comprehend the meaning of the signal. It is the property owner's responsibility to conduct fire drills and other training exercise to make people aware of fire alarm signals and instruct them on the proper reaction to alarm signals.
- In rare instances, the sounding of a warning device can cause temporary or permanent hearing loss.

A fire alarm system will not operate without any electrical power. If AC power fails, the system will operate from standby batteries only for a specified time and only if the batteries have been properly maintained and replaced regularly.

Equipment used in the system may not be technically compatible with the control. It is essential to use only equipment listed for service with your control panel.

Telephone lines needed to transmit alarm signals from a premise to a central monitoring station may be out of service or temporarily disabled. For added protection against telephone line failure, backup radio transmission systems are recommended.

The most common cause of fire alarm malfunction is inadequate maintenance. To keep the entire fire alarm system in excellent working order, ongoing maintenance is required per the manufacturer's recommendations, and UL and NFPA standards. At a minimum, the requirements of Chapter 7 of NFPA 72 shall be followed. Environments with large amounts of dust, dirt or high air velocity require more frequent maintenance. A maintenance agreement should be arranged through the local manufacturer's representative. Maintenance should be scheduled monthly or as required by National and/or local fire codes and should be performed by authorized professional fire alarm installers only. Adequate written records of all inspections should be kept.

Installation Precautions

WARNING - Several different sources of power can be connected to the fire alarm control panel. Disconnect all sources of power before servicing. Control unit and associated equipment may be damaged by removing and/or inserting cards, modules, or interconnecting cables while the unit is energized. Do not attempt to install, service, or operate this unit until this manual is read and understood.

CAUTION - *System Reacceptance Test after Software Changes.* To ensure proper system operation, this product must be tested in accordance with NFPA 72 Chapter 7 after any programming operation or change in site-specific software. Reacceptance testing is required after any change, addition or deletion of system components, or after any modification, repair or adjustment to system hardware or wiring.

All components, circuits, system operations, or software functions known to be affected by a change must be 100% tested. In addition, to ensure that other operations are not inadvertently affected, at least 10% of initiating devices that are not directly affected by the change, up to a maximum of 50 devices, must also be tested and proper system operation verified.

This system meets NFPA requirements for operation at 0-49° C/32-120° F and at a relative humidity of 85% RH (non-condensing) at 30° C/86° F. However, the useful life of the system's standby batteries and the electronic components may be adversely affected by extreme temperature ranges and humidity. Therefore, it is recommended that this system and all peripherals be installed in an environment with a nominal room temperature of 15-27° C/60-80° F.

Verify that wire sizes are adequate for all initiating and indicating device loops. Most devices cannot tolerate more than a 10% I.R. drop from the specified device voltage.

Adherence to the following will aid in problem-free installation with long-term reliability:

Like all solid state electronic devices, this system may operate erratically or can be damaged when subjected to lightning-induced transients. Although no system is completely immune from lightning transients and interferences, proper grounding will reduce susceptibility. *Overhead or outside aerial wiring is not recommended, due to an increased susceptibility to nearby lightning strikes.* Consult with the Technical Services Department if any problems are anticipated or encountered.

Disconnect AC power and batteries prior to removing or inserting circuit boards. Failure to do so can damage circuits.

Remove all electronic assemblies prior to any drilling, filing, reaming, or punching of the enclosure. When possible, make all cable entries from the sides or rear. Before making modifications, verify that they will not interfere with battery, transformer, and printed circuit board location.

Do not tighten screw terminals more than 9 in-lbs. Over-tightening may damage threads, resulting in reduced terminal contact pressure and difficulty with screw terminal removal.

Though designed to last many years, system components can fail at any time. This system contains static-sensitive components. Always ground yourself with a proper wrist strap before handling any circuits so that static charges are removed from the body. Use static-suppressive packaging to protect electronic assemblies removed from the unit.

Follow the instructions in the installation, operating, and programming manuals. These instructions must be followed to avoid damage to the control panel and associated equipment. FACP operation and reliability depend upon proper installation by authorized personnel.

FCC Warning

WARNING: This equipment generates, uses, and can radiate radio frequency energy and if not installed and used in accordance with the instruction manual, may cause interference to radio communications. It has been tested and found to comply with the limits for class A computing device pursuant to Subpart B of Part 15 of FCC Rules, which is designed to provide reasonable protection against such interference when operated in a commercial environment. Operation of this equipment in a residential area is likely to cause interference, in which case the user will be required to correct the interference at his own expense.

Canadian Requirements

This digital apparatus does not exceed the Class A limits for radiation noise emissions from digital apparatus set out in the Radio Interference Regulations of the Canadian Department of Communications.

Le présent appareil numérique n'émet pas de bruits radioélectriques dépassant les limites applicables aux appareils numériques de la classe A prescrites dans le Règlement sur le brouillage radioélectrique édicté par le ministère des Communications du Canada.

This Page Intentionally Left Blank

Table of Contents

1. Introduction to the Charger	7
Overview	7
Figure 1: Charger Features	7
Specifications	8
Compliance with NFPA Codes and UL Standards	8
Charger Maintenance	8
Table 1: Charger Specifications	8
2. Installing the Charger	9
Overview	9
Installation Precautions and Standards	9
Battery Precautions	9
Table 2: Installation Topics	9
Installation Standards	10
Charger Connections, Jumpers, and Switches	10
Figure 2: Charger Connections, Switches, and Jumpers	10
Connecting AC Power to the Charger	11
Figure 3: Using SW1 to Select AC Voltage	11
Figure 4: Connecting AC Power to the Charger	11
Connecting Batteries to the Charger	12
Figure 5: Connecting 25 AH Batteries	12
Table 3: Connecting 25 AH Batteries	12
Figure 6: Connecting Four Batteries to a Charger	13
Table 4: Connecting 55 AH Batteries	13
Mounting the Charger	14
Mounting the Charger into a CAB-A3F or CAB-B3F	14
Figure 7: Mounting a Charger in a CAB-A3F or CAB-B3F	14
Mounting the Charger in a BB-55F Battery Box	15
Figure 8: Mounting a Charger in a BB-55F	15
Connecting the Charger to a Load	16
Connecting the Charger to a Multiple Load -	16
Figure 9: Typical Wiring of a Charger to a Multiple Load	16
Connecting the Charger to an MS-9200 -	17
Figure 10: Typical Wiring of a Charger to an MS-9200	17
Connecting the Charger to an MS-9600 -	18
A charger can be connected to an MS-9600	18
Figure 11: Typical Wiring of a Charger to an MS-9600	18
Adding the Charger for Additional Current	19
Figure 12: Typical Connections for Drawing Additional Current	19
Configuring the Charger	20
Figure 13: Configuring the Charger	20
Delay loss of AC Reporting -	20
Disable Ground Fault Detection -	20
Figure 14: Disabling Ground Fault Detection	20
Trouble and Form-C Relay Connections (Optional)	21
Figure 15: Connections for Optional Devices	21
Table 5: Charger Trouble and Form-C Relay Connections	21

Installing Optional Meters	22
Installing an AM-1	22
Table 6: Optional Meters	22
Figure 16: Mounting an AM-1 or VM-1 to a BB-55F Battery Box	22
Installing a VM-1 -	23
Installing an MPM-3	23
Figure 17: Mounting an MPM-3	23
3. Operating the Charger.....	25
Overview	25
Starting the Charger	25
Understanding the LED Status Indicators.....	25
Figure 18: LED Status Indicators	25
Normal Operation	26
Table 7: LED Status Indicators	26

1. Introduction to the Charger

Overview

The CHG-120F battery charger is designed to charge lead-acid batteries that provide emergency standby power for a Fire Alarm Control Panel (FACP). Two 12-volt batteries are always used in series to supply 24 VDC nominal. The following list gives answers to some common questions about the charger:

Note: Throughout this manual, the term “charger” refers to a CHG-120F.

- **What types of FACP’s can be used with the charger?** Any 24 VDC FACP that uses lead-acid 25 AH to 120 AH batteries *and* that has the feature to disable the FACP battery charger.
- **Where does the charger mount?** You can mount the charger in a CAB-A3F or CAB-B3F Cabinet or in a BB-55F Battery Box.
- **How many outputs does the charger provide?** The charger provides two output circuits for connection to multiple loads (such as a power supply, amplifier, auxiliary amplifier, and so forth).
- **What options are available with the charger?** You can configure the charger to disable the charger’s ground fault detection, to delay AC loss reporting (8 or 16 hours), and to operate with 120 VAC or 240 VAC.
- **How long does it take the charger to charge batteries?** Typically, it takes 9 hours to charge 25 AH batteries, 20 hours to charge 55 AH batteries, and 38 hours to charge 120 AH batteries. Refer to “Specifications” on page 8 for details.

Figure 1 identifies features of the charger:

Note: For detailed descriptions of charger connections, jumpers, and switches, see “Charger Connections, Jumpers, and Switches” on page 10.

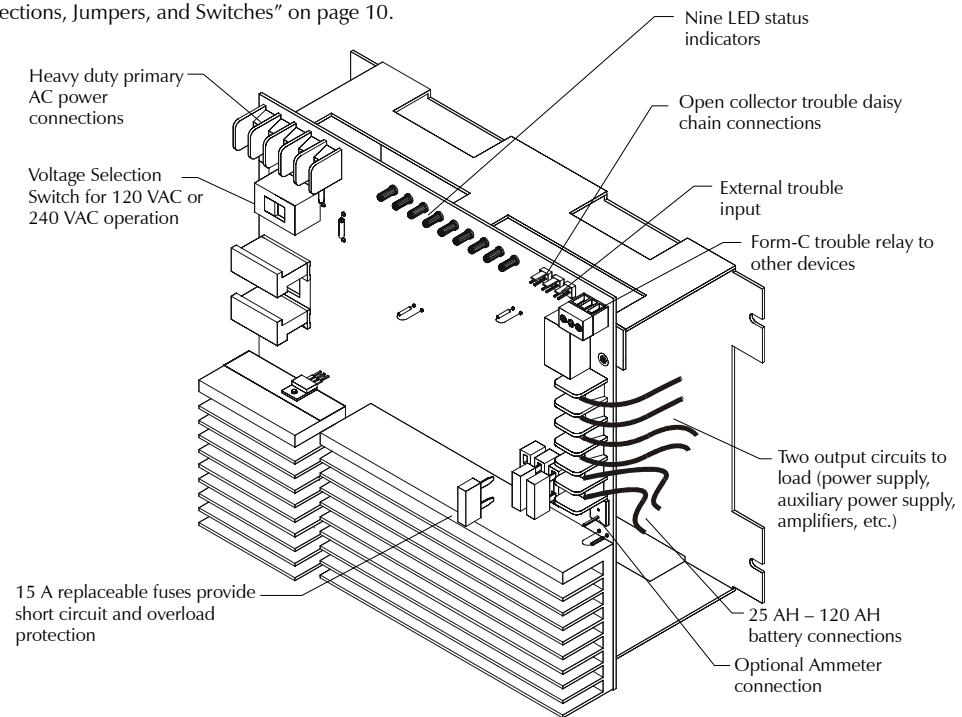

Figure 1 Charger Features

The charger also provides the following features:

- AM-1 ammeter (0-10A) ordered separately
- VM-1 voltmeter (0-50 V) ordered separately
- Disable local ground fault detection
- Selectable reporting delay for loss of AC (8 or 16 hours)

Specifications

Table 1 contains electrical specifications for the charger:

Primary AC power in (TB1)	120 VAC, 60 Hz, 2 A 240 VAC, 50 Hz, 1 A
24 VDC Secondary input power (use in battery calculations for FACP)	60 mA - current draw with AC power loss
Form-C relay (TB3)	5 A at 30 VDC
Float charge voltage	27.6 VDC
Maximum charging current	4.5 A
Fuses F1-F3 (PN 12057)	15 A
Battery sizes	25 AH to 120 AH
Charging Time (to charge two fully discharged batteries)	25 AH – 9 hours 55 AH/60 AH – 20 hours 120 AH – 38 hours

Table 1 Charger Specifications

Compliance with NFPA Codes and UL Standards

The charger complies with the following standards:

- NFPA 72 National Fire Alarm Code
- UL 864 Standard for Control Units for Fire Alarm Systems and UL 1481 Power Supplies for Fire Alarm Systems
- CAN/ULC-S527-M87

Charger Maintenance

The charger does not require regular maintenance. While installing the charger, however, make sure to maintain proper polarity when connecting power leads and battery connections. To ensure optimal operation of the charger, observe the following:

Overload and reverse-polarity protection - Fuses F1, F2 and F3 (15 A, PN 12057) provide overload and reverse-polarity protection. Replace a blown fuse with a fuse with the same rating and type.

Periodic Inspection - Periodically inspect the batteries for corrosion and make sure that corrosive effects to the batteries do not affect the charger or cabinet.

Troubleshooting - Most problems with a charger are due to faulty batteries or loose connections. If you encounter problems, inspect the charger, the battery, and all connections for loose wiring or short circuits.

Replacing Batteries - Replacement batteries must have the same charge rate and capacity as other batteries in the set. For example, if replacing one of four 55 AH batteries, make sure the new battery has the same charge rate and capacity as the other three batteries.

2. Installing the Charger

Overview

This section contains instructions and illustrations for installing the charger, divided into the following topics:

Section	Topic(s) Covered	Page
Installation Precautions and Standards	Precautions to take when installing the charger and recommended installation standards.	9
Charger Connections, Jumpers, and Switches	Location and references to connections, jumpers, and switches used to configure, maintain, and operate the charger.	10
Connecting AC Power to the Charger	How to connect AC power to the charger.	11
Connecting Batteries to the Charger	How to connect batteries to the charger in two configurations: using two batteries and using four batteries.	12
Mounting the Charger	How to mount the charger to a CAB-A3F or CAB-B3F. How to mount the charger to a BB-55F.	14
Connecting the Charger to a Load	Instructions and illustrations for wiring a charger to a multiple load and for wiring a charger for a large system installation.	16
Configuring the Charger	Configuring the charger for the following options: Delaying loss of AC reporting (DACT); and Disabling ground fault detection	20
Trouble and Form-C Relay Connections (Optional)	Instructions and illustrations for connecting the following: Open Collector Trouble In (JP5) Trouble Out (JP4) Master Trouble In (JP6) Form-C Trouble Relay (TB3)	21
Installing Optional Meters	How to install an optional ammeter, voltmeter, or both.	22

Table 2 Installation Topics

Installation Precautions and Standards



Battery Precautions When installing the charger, observe the following precautions:

- Observe polarity when making connections.
- Do not connect the Battery Interconnect Cable until instructed.
- Batteries, although sealed, contain hazardous acid chemicals.
- Charging batteries can cause flammable hydrogen gas.
- Take care when handling batteries: batteries are heavy—Be careful when lifting and handling them.
- Mounting batteries requires proper mounting hardware. Follow the battery manufacturer's installation instructions

Installation Standards An installer should be familiar with the following standards:

- NEC Article 300 Wiring Methods.
- NEC Article 760 Fire Protective Signaling Systems.
- Applicable Local and State Building Codes.
- Requirements of the Authority Having Jurisdiction.

Charger Connections, Jumpers, and Switches

Figure 2 illustrates all connections, jumpers, and switches needed to maintain, configure, and operate the charger:

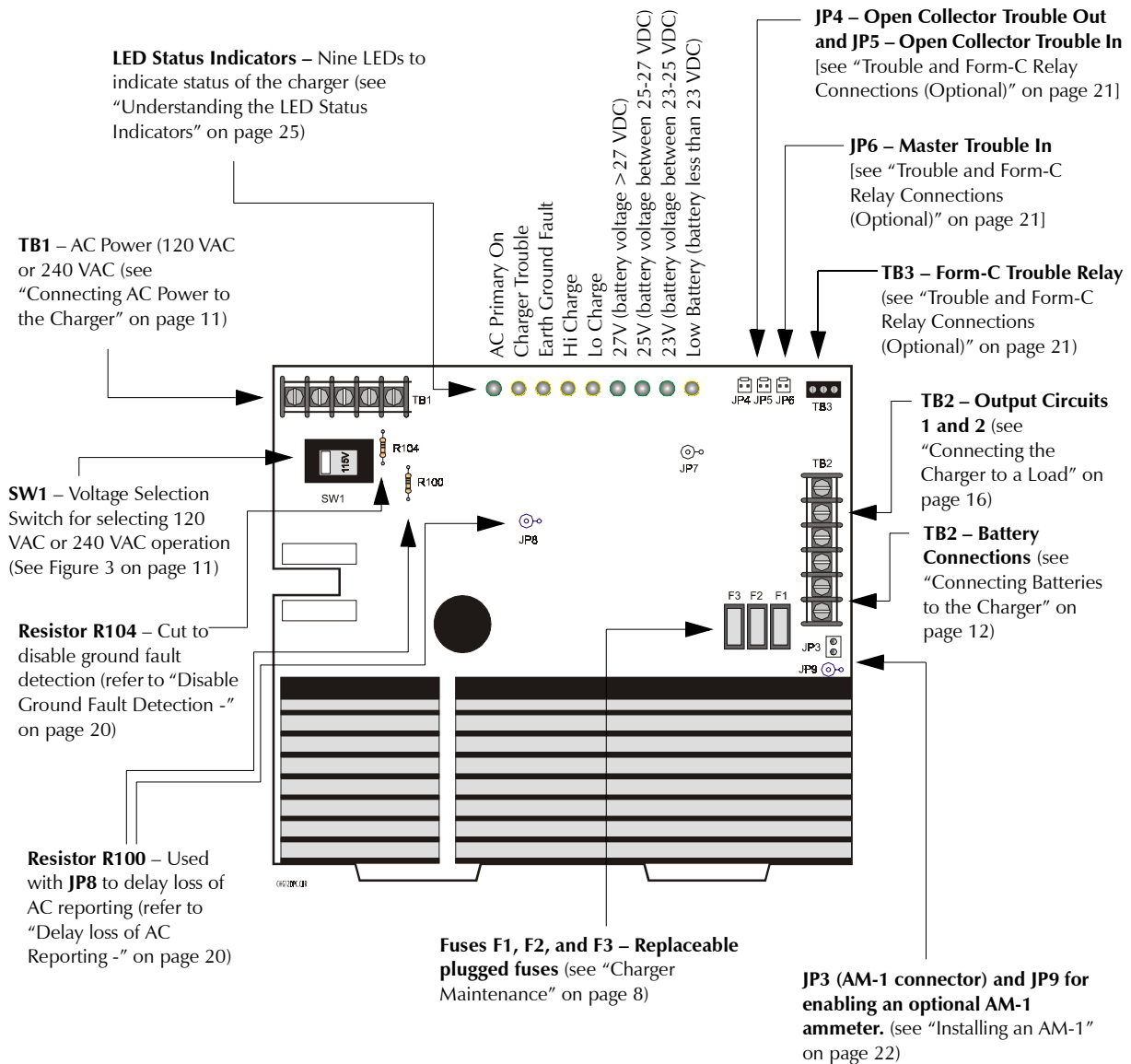
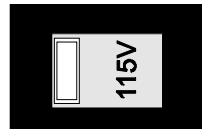

Figure 2 Charger Connections, Switches, and Jumpers

Connecting AC Power to the Charger

Caution: Before connecting AC power to the charger—make sure to set the Voltage Select Switch (SW1) on the charger (Figure 2) to match your AC power source (120 VAC or 240 VAC). Figure 3 shows the voltage selection positions for SW1:

Note: The charger is rated for 120 VAC or 240 VAC operation. Therefore, 115V on SW1 indicates 120 VAC operation; and 230V, indicates 240 VAC operation.



SW1
SW1 set to 120 VAC operation

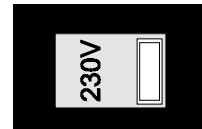

SW1
SW1 set to 240 VAC operation

Figure 3 Using SW1 to Select AC Voltage

Figure 4 shows the steps for connecting the charger to the main AC power source.

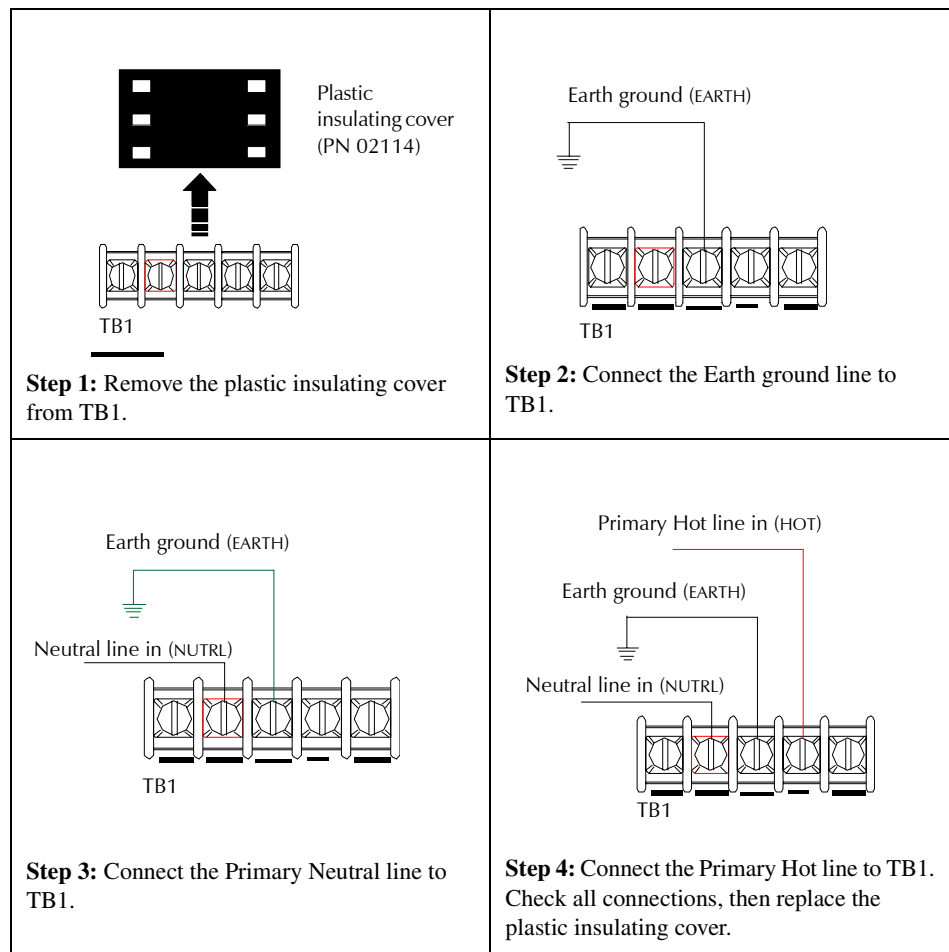

Figure 4 Connecting AC Power to the Charger

Connecting Batteries to the Charger

Overview - 25 AH –120 AH batteries can be connected to the charger. This section provides illustrations and instructions for connecting two batteries or for connecting four batteries.

Connecting Two Batteries - Figure 5 illustrates how to connect two 25 AH batteries to the charger:

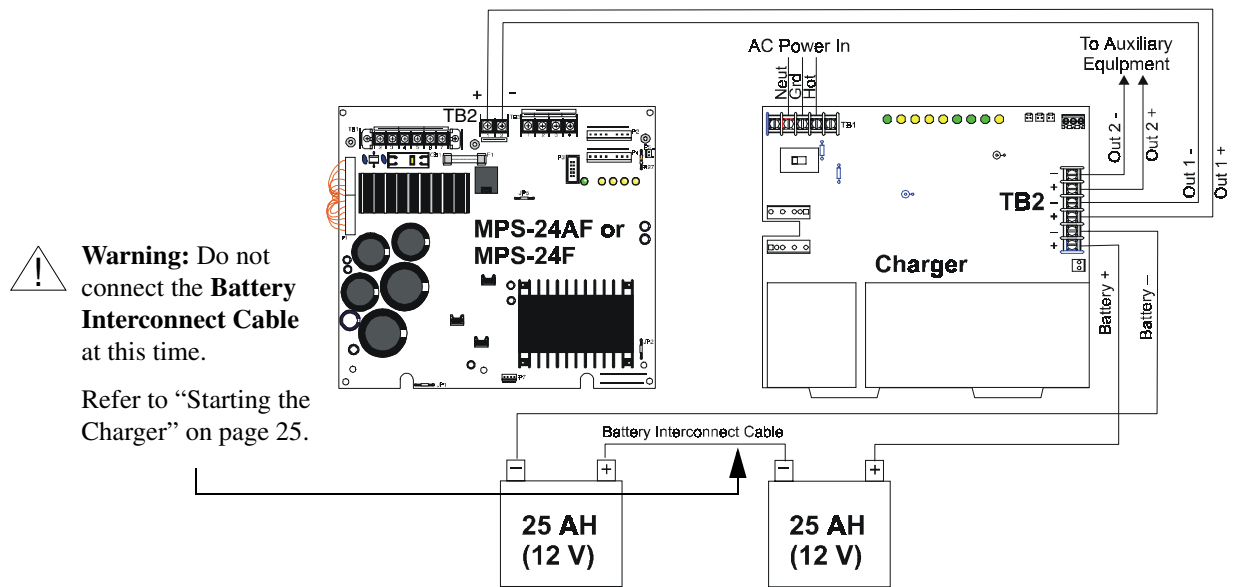

Figure 5 Connecting 25 AH Batteries

Table 3 contains instructions for connecting batteries to the charger:

Step	Action
1	Remove all power sources to the charger.
2	Connect the battery negative cable to the TB2 terminal (on the charger) labeled “Battery -” as shown in Figure 5.
3	Connect the battery positive cable to the TB2 terminal (on the charger) labeled “Battery +” as shown in Figure 5.
4	Proceed to the section “Connecting the Charger.” <i>Do not connect the Battery Interconnect Cable at this time</i> —refer to “Starting the Charger” on page 25.

Table 3 Connecting 25 AH Batteries

Connecting Four Batteries - Figure 6 illustrates how to connect four 55 AH batteries to the charger:



Warning: Do not connect the **Battery Interconnect Cable** at this time.
Refer to “Starting the Charger” on page 25.

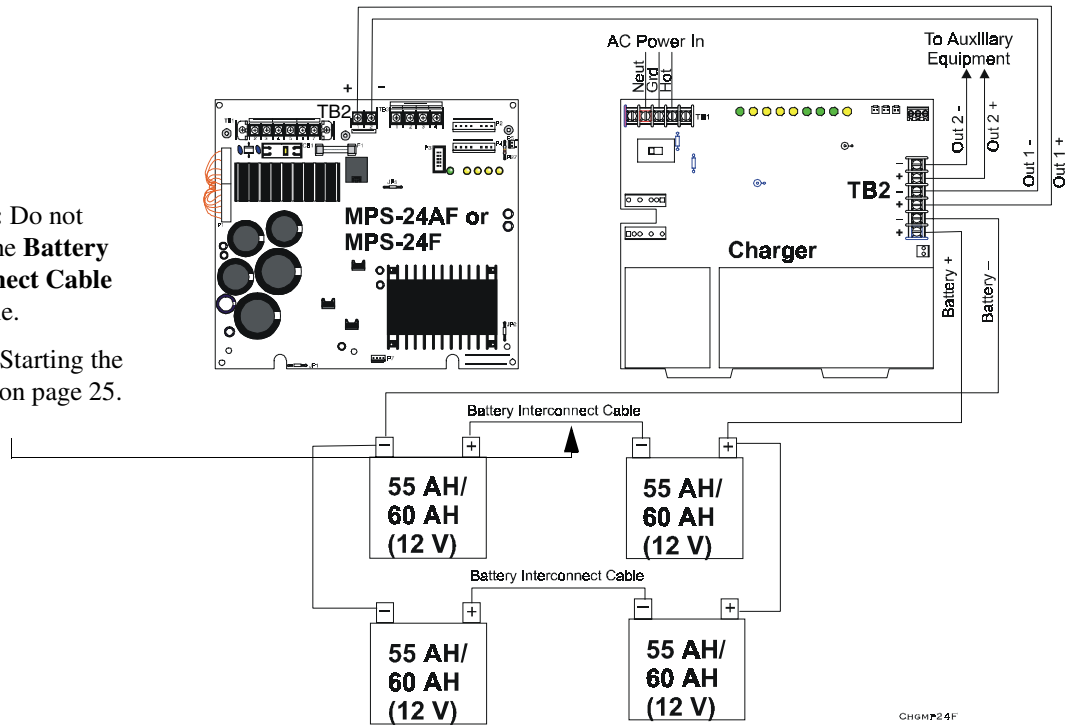

Figure 6 Connecting Four Batteries to a Charger

Table 4 contains instructions for connecting four batteries to the charger:

Step	Action
1	Remove all power sources to the charger.
2	Tie the batteries in pairs by connecting the battery negative terminals and the battery positive terminals as shown in Figure 6.
3	Connect the battery negative cable to the TB2 terminal (on the charger) labeled “Battery -” as shown in Figure 6.
4	Connect the battery positive cable to the TB2 terminal (on the charger) labeled “Battery +” as shown in Figure 6.
5	Proceed to the section “Connecting the Charger.” <i>Do not connect the Battery Interconnect Cable at this time</i> —refer to “Starting the Charger” on page 25.

Table 4 Connecting 55 AH Batteries

Mounting the Charger

Mounting the Charger into a CAB-A3F or CAB-B3F A charger can be mounted into the bottom row of a CAB-A3F or CAB-B3F Cabinet, as long as the charger is within 20 feet of the load. Typically, a charger mounts into the lower right corner of the CAB-A3F or CAB-B3F—next to the power supply (Figure 7, position 2). If using an additional CAB-A3F or CAB-B3F, the charger can be mounted in the lower left corner (Figure 7, position 2). Figure 7 shows the two mounting positions of a charger in a CAB-A3F or CAB-B3F.

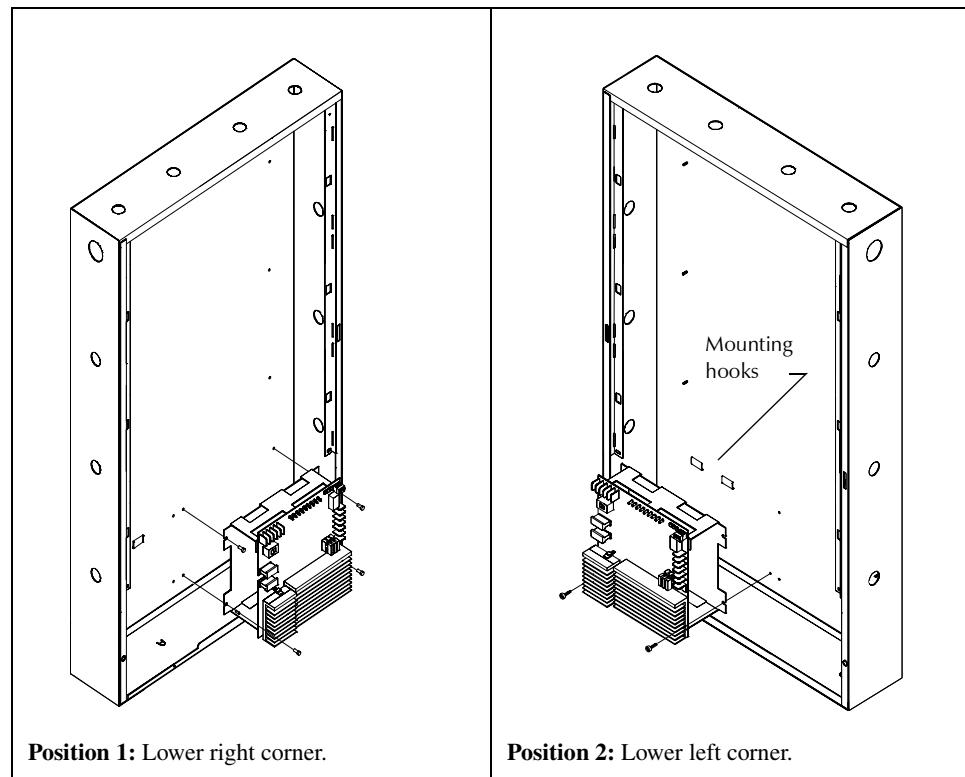

Figure 7 Mounting a Charger in a CAB-A3F or CAB-B3F

To mount a charger in a CAB-A3F or CAB-B3F Cabinet, follow these instructions:

Step	Action
1	Align the charger chassis mounting slots with the mounting holes in the cabinet. If mounting in position 2, place the charger chassis on the mounting hooks in the cabinet.
2	Insert the self-tapping screws through the charger chassis mounting slots and into the mounting holes in the cabinet.
3	Tighten the self-tapping screws.

Mounting the Charger in a BB-55F Battery Box A charger can be mounted in a BB-55F battery box, provided the BB-55F is within 20 feet of the load. Note that a charger takes up half the space in the BB-55F. This means there will be space remaining for only two 25 AH batteries in the BB-55F. Figure 8 illustrates the mounting position of a charger in a BB-55F.

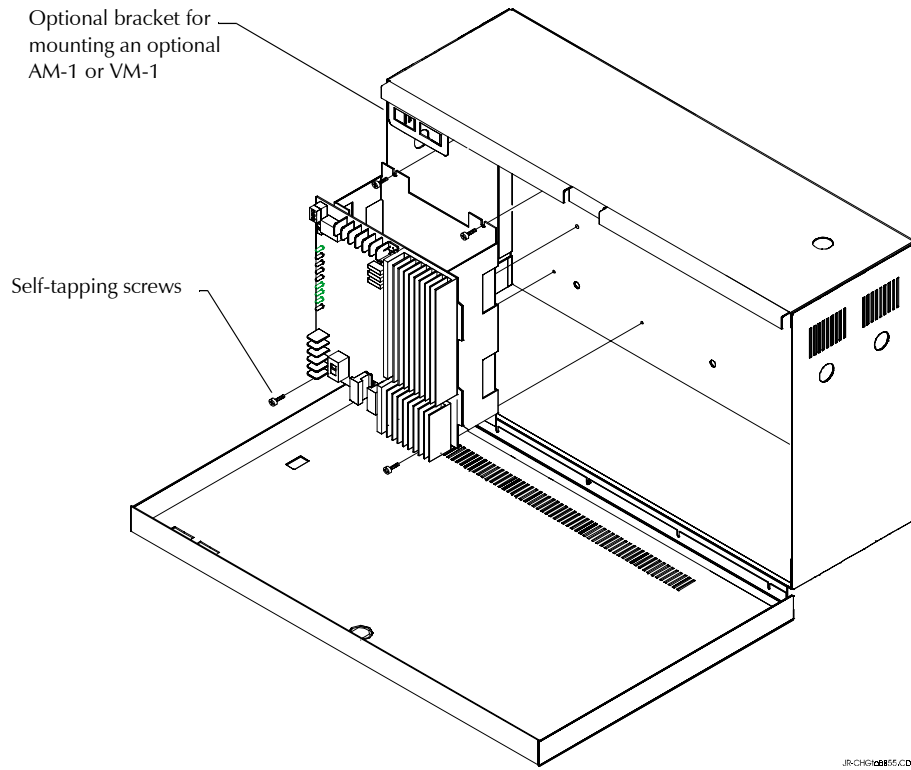

Figure 8 Mounting a Charger in a BB-55F

To mount a charger in a BB-55F battery box, follow these instructions:

Step	Action
1	Align the charger chassis mounting slots with the mounting holes in the BB-55F.
2	Insert the self-tapping screws through the charger chassis mounting slots and into the mounting holes in the BB-55F.
3	Tighten the self-tapping screws.

Connecting the Charger to a Load

This section provides four applications for connecting a charger to a load. While connecting a charger to a load, observe the following precautions:

- Make sure all power has been removed from the charger and the load.
- Observe polarity when making connections.

Note: Figure 12 is a wiring diagram which illustrates the connection of a load to battery terminals in order to obtain additional current.

Connecting the Charger to a Multiple Load - A charger can be connected to multiple loads, such as a main power supply, auxiliary power supply and so forth, as illustrated in Figure 9.

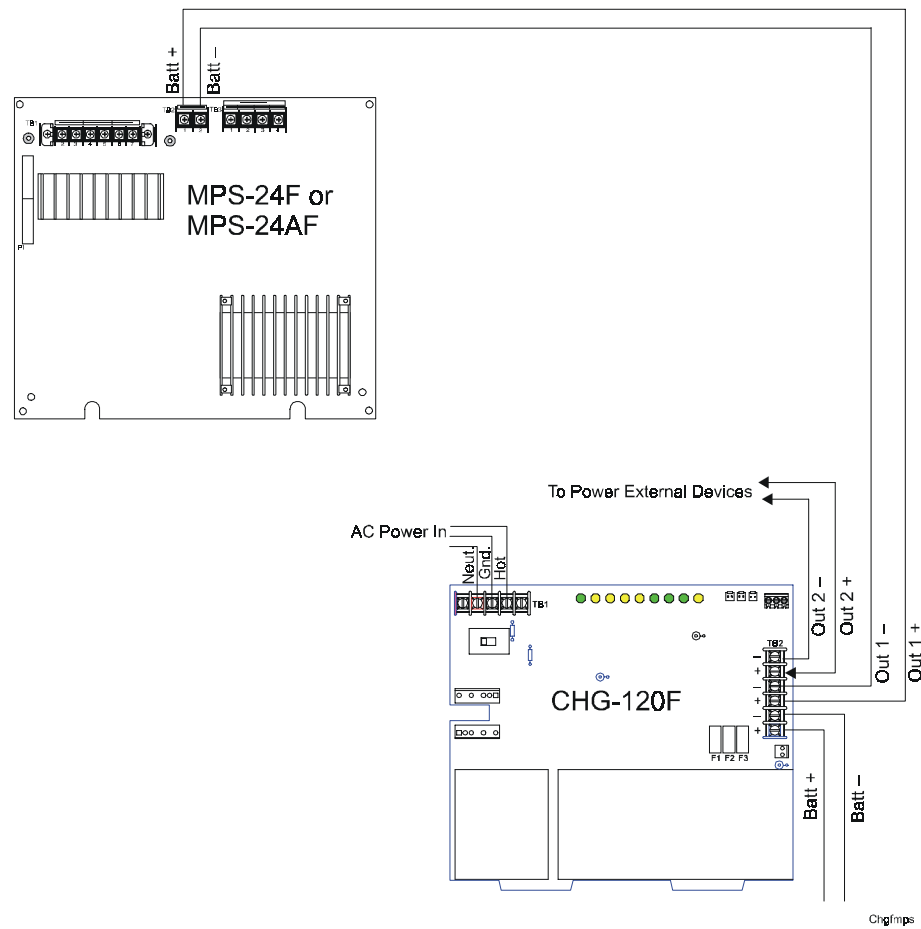

Figure 9 Typical Wiring of a Charger to a Multiple Load

To connect a charger as shown in Figure 9, follow these steps:

Step	Action
1	Connect the battery+ and battery- terminals of the power supply to the charger output circuit (TB2: Out 1+ and Out 1-) as shown in Figure 9.
2	Connect the battery+ and battery- terminals of an optional external device to the charger output circuit (TB2: Out 2+ and Out 2-) as shown in Figure 9.
3	Connect the batteries to the charger (for battery connections see Figure 5 or Figure 6).

Connecting the Charger to an MS-9200 - A charger can be connected to an MS-9200 (requires MS-9200 circuit board #71741, or later) by disabling the local charger by cutting jumper JP1 as illustrated in Figure 10.

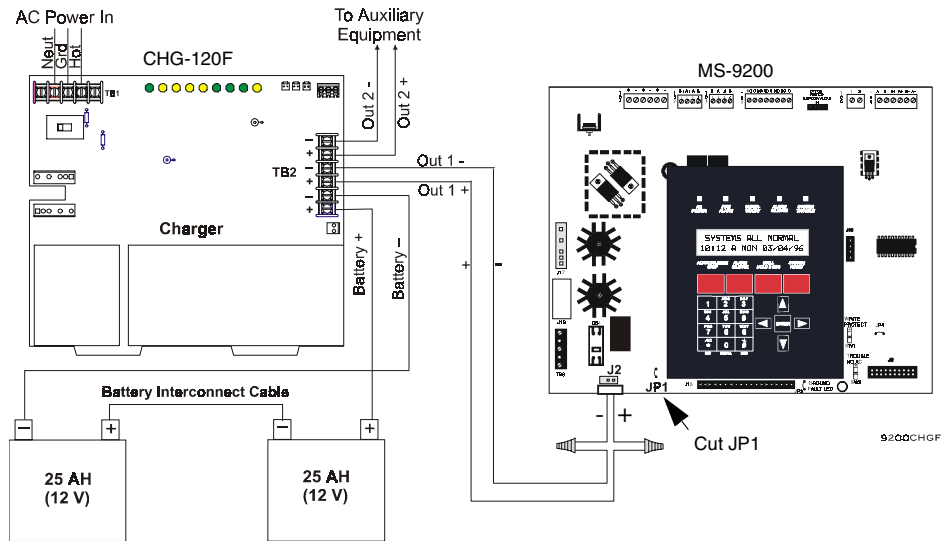

Figure 10 Typical Wiring of a Charger to an MS-9200



WARNING! Do not attempt to connect the CHG-120F to the older version MS-9200 FACP main circuit board #03317, which does not allow disabling of the FACP battery charger (no JP1 jumper). System damage will result.

To connect a charger as shown in Figure 10, follow these steps:

Step	Action
1	Cut jumper JP1, on the MS-9200 main circuit board (#71741, available June 1, 1998) only, to disable the FACP battery charger.
2	Cut the battery cable connected to J2 on the MS-9200 and wire nut to wires connected to the charger output circuit (TB2: Out 1+ and Out 1-) as shown in Figure 10. Be certain to observe polarity.
3	If needed, connect the battery+ and battery- terminals of an optional external device to the charger output circuit (TB2: Out 2+ and Out 2-) as shown in Figure 10.
4	Connect the batteries to the charger (for battery connections see Figure 5 or Figure 6).

Connecting the Charger to an MS-9600 - A charger can be connected to an MS-9600 as illustrated in Figure 11.

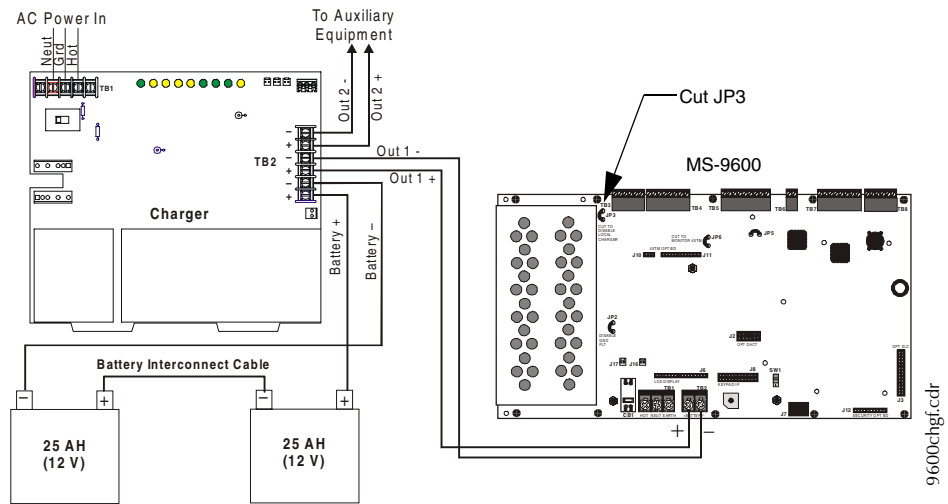

Figure 11 Typical Wiring of a Charger to an MS-9600

To connect a charger as shown in Figure 11, follow these steps:

Step	Action
1	Cut jumper JP3, on the MS-9600 main circuit board to disable the FACP battery charger.
2	Connect the battery cables between TB2 (+ and -) on the MS-9600 and the CHG-120F charger output circuit (TB2: Out 1+ and Out 1-) as shown in Figure 11. Be certain to observe polarity.
3	If needed, connect the battery+ and battery- terminals of an optional external device to the charger output circuit (TB2: Out 2+ and Out 2-) as shown in Figure 11.
4	Connect the batteries to the charger (for battery connections see Figure 5 or Figure 6).

Adding the Charger for Additional Current Due to internal fuses, the maximum alarm current that can be drawn from the batteries and passed through the charger’s two output circuits is limited to 10 amps maximum (each circuit). The PS-12600 batteries, however, are capable of supplying up to 45 amps of current in alarm. The remaining 25 amps of alarm current can be drawn directly from the battery terminals to supply Notification Appliance Circuits, control modules and other alarm devices as illustrated in Figure 12

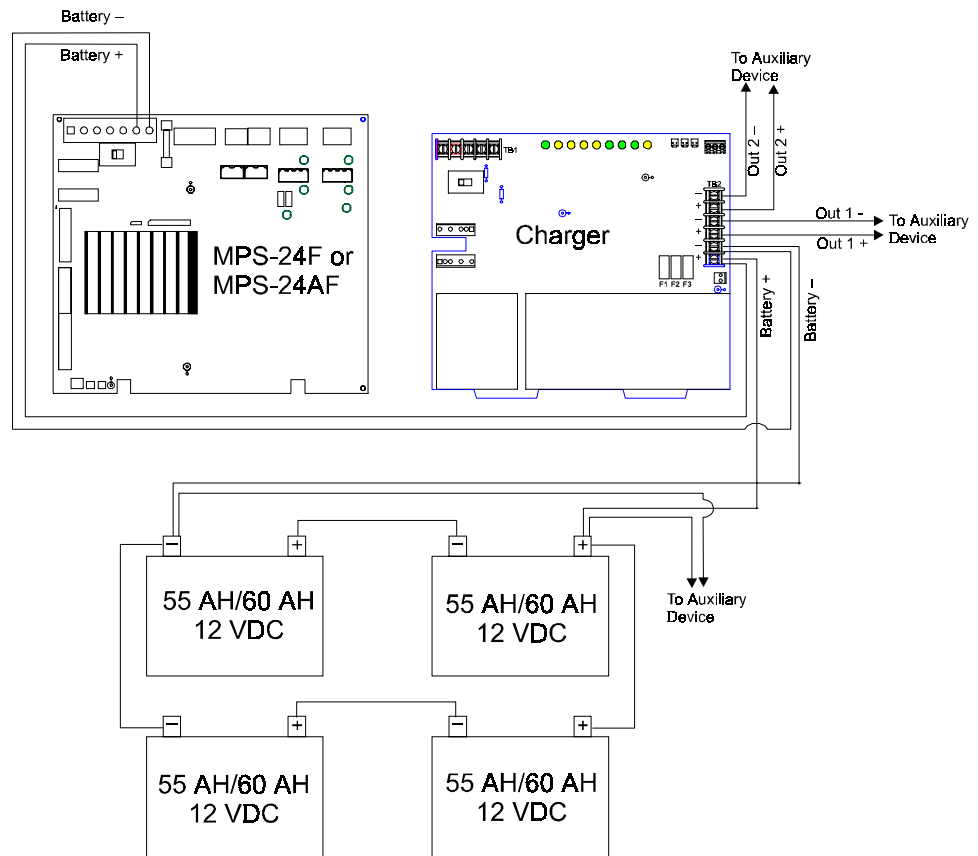

Figure 12 Typical Connections for Drawing Additional Current

To connect a charger as shown in Figure 12, follow these steps:

Step	Action
1	Connect the Battery+ and Battery- terminals of the power supply to the charger Battery output (TB2: Batt 1+ and Batt 1-) as shown in Figure 12.
2	Connect the Battery+ and Battery- terminals of the first auxiliary device to the charger output circuit (TB2: Out 2+ and Out 2-) as shown Figure 12.
3	Connect the Battery+ and Battery- terminals of the second auxiliary device to the charger output circuit (TB2: Out 1+ and Out 1-) as shown in Figure 12.
4	Connect the Battery+ and Battery- terminals of the third auxiliary device to the batteries as shown in Figure 12.
5	Connect the batteries to the charger.

Configuring the Charger

The charger can be configured to do the following:

- Receive 120 VAC or 240 VAC input power (see Figure 3 on page 11).
- Delay AC loss reporting (for Central Station applications); and
- Disable charger ground fault detection.

Figure 13 shows how to configure the charger for delaying the loss of AC reporting and for disabling ground fault detection:

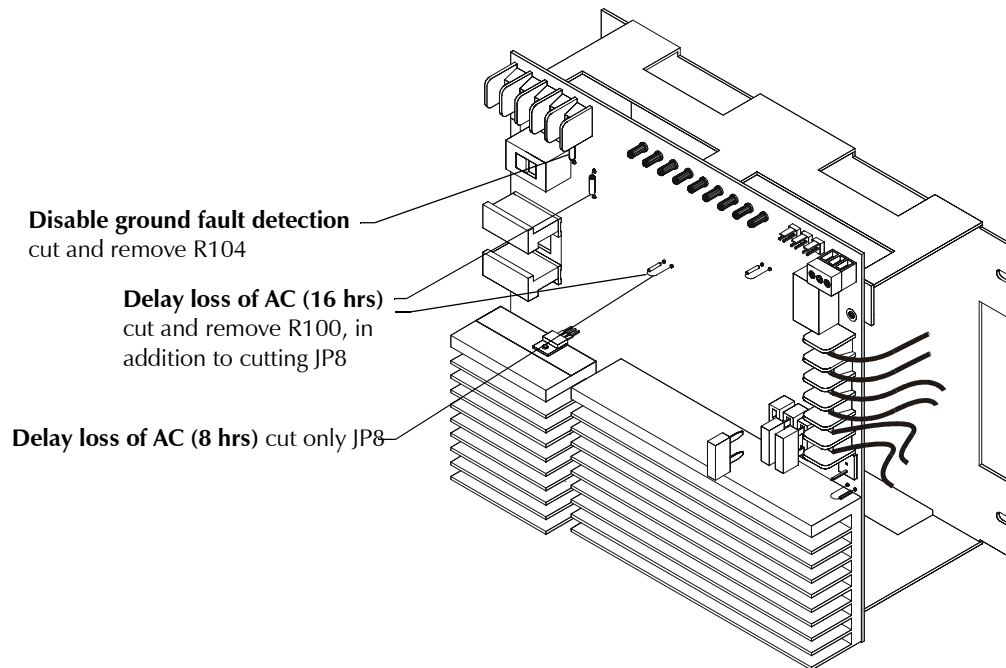

Figure 13 Configuring the Charger

Delay loss of AC Reporting - If using a Digital Alarm Communicator (DACT), you must delay the reporting of an AC loss condition to a central station. This delays activation of the trouble bus and Form-C trouble contacts when AC fails. You can configure the charger for an 8-hour or a 16-hour delay as follows:

- 8-hour delay – Cut and remove jumper JP8 on the charger (Figure 13).
- 16-hour delay – Cut jumper JP8; then, cut and remove resistor R100 (Figure 13).

Disable Ground Fault Detection - To disable local (charger) earth fault detection, cut and remove resistor R104 (Figure 13). Figure 14 contains a simplified block diagram that shows ground fault detection disabled on a charger connected to a power supply:

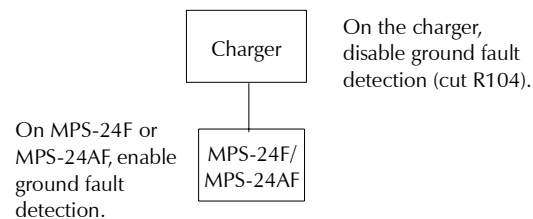

Figure 14 Disabling Ground Fault Detection

Trouble and Form-C Relay Connections (Optional)

Table 5 contains descriptions of optional connectors on the charger:

Function	Connector
Use open collector input and output to daisy chain a trouble signal through the charger without affecting charger operation.	JP5 Open Collector Trouble In JP4 Open Collector Trouble Out
Receive trouble signals from another device, such as a spare zone.	JP6 Master Trouble In
Transmit a charger trouble signal to another device.	TB3 Form-C Trouble Relay

Table 5 Charger Trouble and Form-C Relay Connections

Figure 15 shows charger trouble and Form-C relay connections:

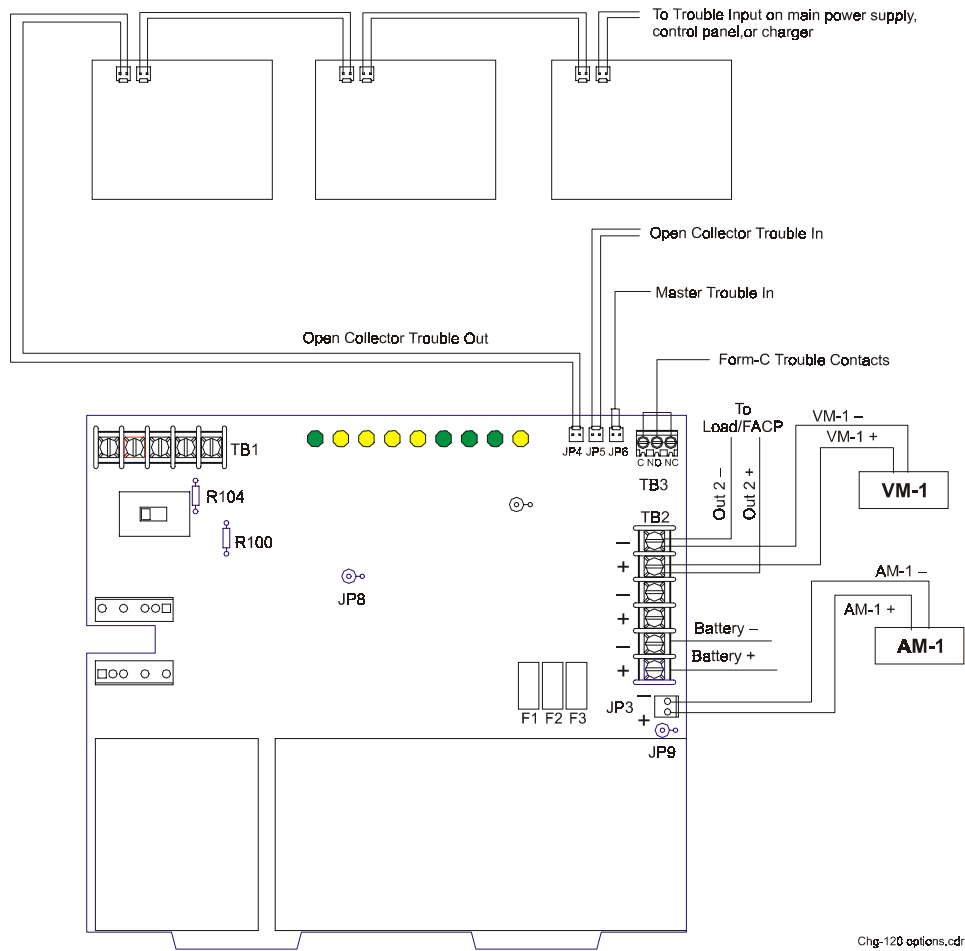

Figure 15 Connections for Optional Devices

Installing Optional Meters

You can also order and install a ammeter (AM-1), voltmeter (VM-1), or both (MPM-3) for use with the charger. If mounting an AM-1 or a VM-1, mount the meter to a BB-55F as shown in Figure 16. If mounting an MPM-3, mount to a power supply (Figure 17) installed in a CAB-A3F or CAB-B3F. Table 6 contains descriptions and part numbers for these optional meters:

Item	Part Number	Description
Ammeter	AM-1	0-10 A ammeter with a 3-ft. cable for connection to the charger (JP3). Mounts into a BB-55F battery box only.
Voltmeter	VM-1	0-50 V voltmeter with 3-ft. positive and negative leads for connection to the charger output circuit. Mounts into a BB-55F battery box only.
Ammeter and Voltmeter Assembly	MPM-3	An AM-1 and VM-1 attached to a mounting bracket. Mounts onto a power supply.

Table 6 Optional Meters

Installing an AM-1 To install an AM-1, follow these steps:

1. Cut jumper JP9 on the charger (Figure 15).
2. Mount the AM-1 into a mounting slot on the front of the BB-55F (Figure 16).
3. Connect the AM-1 harness to JP3 on the charger (Figure 15)—making sure to observe proper polarity.

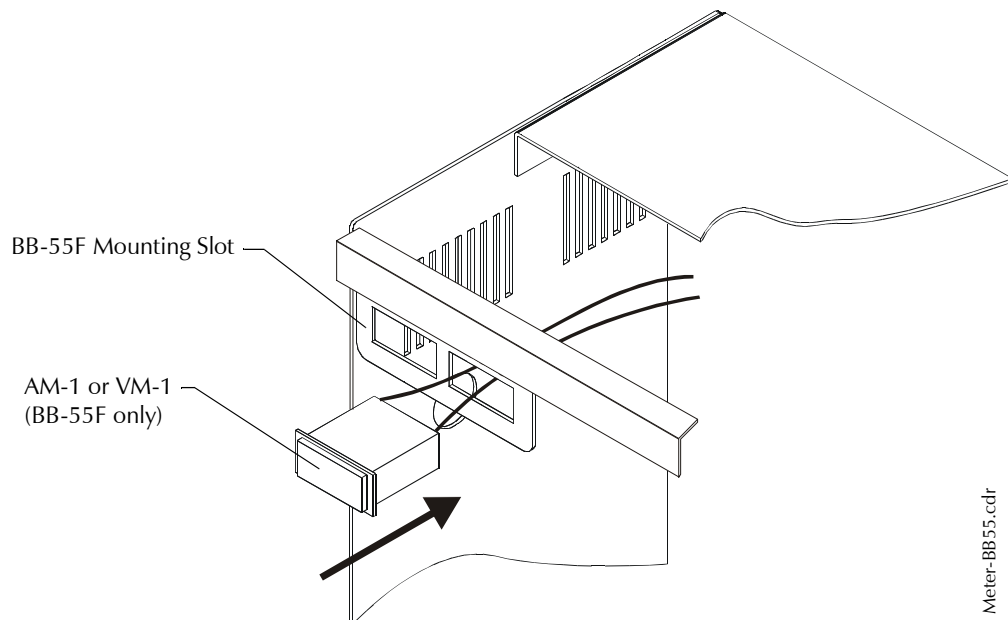

Figure 16 Mounting an AM-1 or VM-1 to a BB-55F Battery Box

Installing a VM-1 - A VM-1 can be connected across a charger output circuit. For example, to install a VM-1 to measure voltage from charger output circuit 1, follow these steps:

1. Mount the VM-1 into a mounting slot on the front of the BB-55F battery box.
2. Connect the positive lead to TB2 Out 1 (+). See Figure 15.
3. Connect the negative lead to TB2 Out 1 (-). See Figure 15.

Installing an MPM-3 To install an MPM-3, follow these steps:

1. Connect the AM-1 (Figure 15).
2. Connect the VM-1 (Figure 15).
3. Mount the MPM-3 onto a power supply connected to your system, such as an MPS-24F or MPS-24AF (Figure 17).

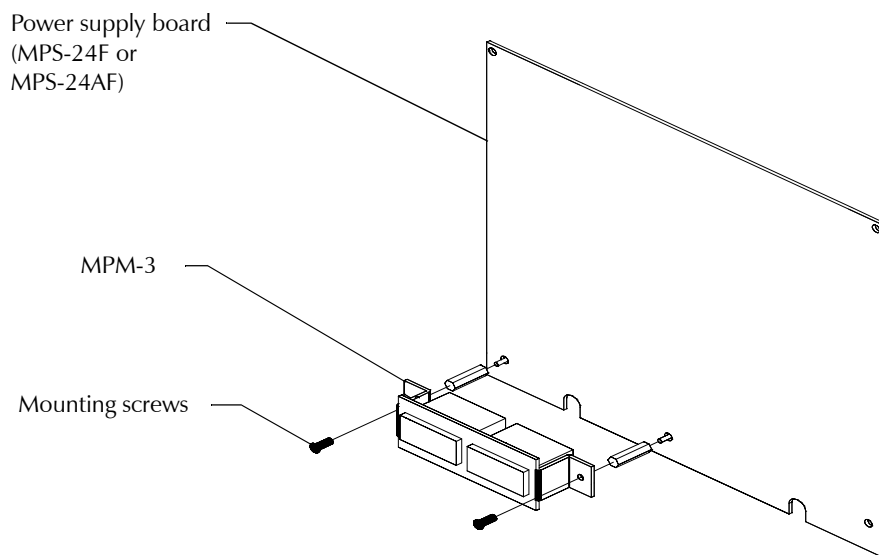

Figure 17 Mounting an MPM-3

Notes

3. Operating the Charger

Overview

This section contains information on starting the charger, interpreting the LED Status Indicators on the charger, and normal operation of the charger.

Starting the Charger

Warning: Before starting the charger, do the following:

- Follow the installation instructions in Section 2, “Installing the Charger.”
- Verify proper polarity on all connections between the charger and the batteries, load, and optional meters.
- Make sure there are no short circuits between leads and between battery terminals
- Make sure the Battery Interconnect Cable(s) is not connected

To start the charger, follow these steps:

1. Connect AC power to the charger. The AC On LED and Trouble LED turn on
2. Connect the batteries to the charger
3. Connect the Battery Interconnect Cable. The Trouble LED turns off
4. Connect the charger to the load (such as a power supply, an amplifier, etc.)

Understanding the LED Status Indicators

The charger provides nine LED Status Indicators, which are identified in Figure 18. Also refer to Table 7 for conditions, such as troubles, that cause LEDs to light.

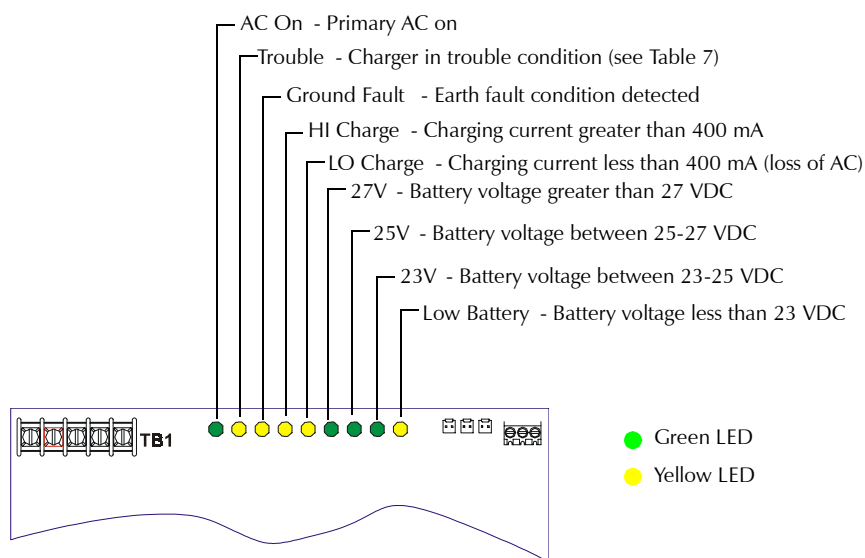

Figure 18 LED Status Indicators

Table 7 shows the conditions that cause the charger LEDs to come on:

LED	Normal Operation	AC Trouble	Disconnected Battery	Ground Fault	Short Circuit	Faulty Battery (or less the 21 V)	Trouble (with AC Trouble Delay used)	Trouble (Master Trouble In JP6 connected)
AC On	★		★	★	★	★		★
Trouble		★	★	★	★	★	★	★
Ground Fault				★				
HI Charge	☆	☆		☆		☆		☆
LO Charge (Loss of AC)	☆	★	★	☆		☆	★	☆
27 V	☆	☆	★	☆			☆	☆
25 V	☆	☆		☆			☆	☆
23 V	☆	☆		☆			☆	☆
Low Battery	☆	☆		☆	★	★	☆	☆
Legend: ★ LED on. ☆ LED on or off, depending on battery voltage. Refer to “Normal Operation.”								

Table 7 LED Status Indicators

Normal Operation

The CHG-120F charges batteries at 4.5 A. When batteries are fully charged, the charger maintains a float charge of 27.6 VDC at a trickle charge rate of less than 400 mA. While charging the batteries, the HI and LO Charge LEDs switch on and off approximately every 20 seconds. Also, one of the 23 V, 25 V, 27 V, or Low Battery LEDs also comes on, depending on the battery voltage.

Limited Warranty

The manufacturer warrants its products to be free from defects in materials and workmanship for eighteen (18) months from the date of manufacture, under normal use and service. Products are date-stamped at time of manufacture. The sole and exclusive obligation of the manufacturer is to repair or replace, at its option, free of charge for parts and labor, any part which is defective in materials or workmanship under normal use and service. For products not under the manufacturer's date-stamp control, the warranty is eighteen (18) months from date of original purchase by the manufacturer's distributor unless the installation instructions or catalog sets forth a shorter period, in which case the shorter period shall apply. This warranty is void if the product is altered, repaired, or serviced by anyone other than the manufacturer or its authorized distributors, or if there is a failure to maintain the products and systems in which they operate in a proper and workable manner. In case of defect, secure a Return Material Authorization form from our customer service department. Return product, transportation prepaid, to the manufacturer.

This writing constitutes the only warranty made by this manufacturer with respect to its products. The manufacturer does not represent that its products will prevent any loss by fire or otherwise, or that its products will in all cases provide the protection for which they are installed or intended. Buyer acknowledges that the manufacturer is not an insurer and assumes no risk for loss or damages or the cost of any inconvenience, transportation, damage, misuse, abuse, accident, or similar incident.

THE MANUFACTURER GIVES NO WARRANTY, EXPRESSED OR IMPLIED, OF MERCHANTABILITY, FITNESS FOR ANY PARTICULAR PURPOSE, OR OTHERWISE WHICH EXTEND BEYOND THE DESCRIPTION ON THE FACE HEREOF. UNDER NO CIRCUMSTANCES SHALL THE MANUFACTURER BE LIABLE FOR ANY LOSS OF OR DAMAGE TO PROPERTY, DIRECT, INCIDENTAL, OR CONSEQUENTIAL, ARISING OUT OF THE USE OF, OR INABILITY TO USE THE MANUFACTURER'S PRODUCTS. FURTHERMORE, THE MANUFACTURER SHALL NOT BE LIABLE FOR ANY PERSONAL INJURY OR DEATH WHICH MAY ARISE IN THE COURSE OF, OR AS A RESULT OF, PERSONAL, COMMERCIAL, OR INDUSTRIAL USE OF ITS PRODUCTS.

This warranty replaces all previous warranties and is the only warranty made by the manufacturer. No increase or alteration, written or verbal, of the obligation of this warranty is authorized.



World Headquarters
One Fire-Lite Place, Northford, CT 06472-1653 USA
203-484-7161 • Fax 203-484-7118
www.firelite.com

ISO 9001
CERTIFIED
ENGINEERING & MANUFACTURING