

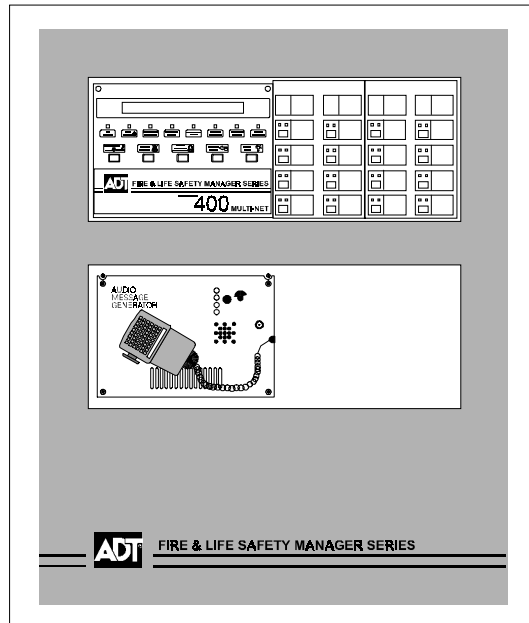

ADT Security Services, Inc.
1750 Clint Moore Road
Boca Raton, FL 33431
(561) 988-3600



Unimode 400 Multi-Net Analog Fire Panel

Installation Manual

Document 50710

10/22/97

Revision:

A

PN 50710:A

ECN 97-178

Table of Contents

1. System Overview

Introduction	1-1
About this Manual	1-1
Description	1-1
Standard Features and Options.....	1-2
System Limitations.....	1-2
System Diagram	1-3
Specifications	1-4
Overview	1-4
AC Power	1-4
Battery (sealed lead-acid only).....	1-4
Signaling Line Circuit (SLC) Loop.....	1-4
Notification Appliance and Releasing Circuits (MPS-400 ICM-4, ICE-4)	1-5
Relays	1-5
Four-wire Smoke Detector Power.....	1-5
Power Outputs.....	1-6
Operating Power.....	1-6
AC Branch Circuit	1-6
Secondary Power Source (Batteries)	1-6
System Components	1-7
Basic Equipment Packages	1-7
ADT-CPU	1-7
Power Supplies.....	1-8
Audio Amplifiers	1-9
Transformer Assembly and MPS-400PCA.....	1-9
Battery Boxes	1-9
Optional Devices	1-10
Intelligent Detectors	1-11
Overview	1-11
Detector Descriptions.....	1-11
Addressable Modules	1-12
Overview	1-12
Module Descriptions	1-12
End-of-Line Devices	1-13
Annunciation Modules	1-14
Overview	1-14
ADT-LDM Series Lamp Driver Modules.....	1-14
Annunciator Control System (ACS)	1-15
Annunciator Fixed Modules.....	1-15
Peripheral Displays and Printers	1-16
Overview	1-16
ADT-LCD-80 Display	1-16
PRN-4 Remote Printer	1-16
Keltron Remote Printer (Model VS4095).....	1-16
CRT-2 Terminal	1-16
Notification Circuit and Control Modules	1-17
Overview	1-17
Descriptions of Modules	1-17
Voice Alarm Equipment	1-18
Overview	1-18
Audio Message Generator (AMG-1)	1-18

Audio Tone Generator (ATG-2)	1-18
Fire Fighters Telephone FFT-7/FFT-7S.....	1-18
Voice Control Module (VCM-4)	1-18
Dual Channel Module (DCM-4)	1-18
Cabinet Hardware	1-19
Cabinet Overview.....	1-19
CHS-4M Chassis/Dress Panel Assembly	1-19
CHS-4L Chassis	1-19
ADT-CAB-X3 Series Cabinets	1-20
Overview	1-20
ADT-CAB-A3	1-20
ADT-CAB-B3.....	1-20
ADT-CAB-C3.....	1-21
ADT-CAB-D3	1-21
ADT-CAB-400AA Cabinets.....	1-22
ADT-CAB-400AA Overview	1-22
ADT-CAB-400AA Limitations	1-22
ADT-CAB-400AA Dimensions	1-22
2. Installation	
Preparing for Installation	2-1
Installation Checklist	2-2
Installing a Cabinet Door	
Cabinet Door Mounting Guidelines	2-4
How to Install a Cabinet Door (ADT-CAB-X3 only).....	2-4
Installing the Door Alignment Tabs.....	2-5
Installing a Chassis (ADT-CAB-X3 Series Cabinets)	
Overview	2-6
Installing a CHS-4 Chassis.....	2-6
Installing a CHS-4L Chassis	2-6
Mounting a Backbox (SBB-X3 and ADT-CAB-400AA)	2-7
Mounting an MPS-400 Power Supply	
Mounting an MPS-400 into an ADT-CAB-X3 Cabinet	2-8
Mounting an MPS-400 into an ADT-CAB-400AA	2-9
Mounting an Optional AVPS-24 Power Supply	
Overview	2-10
Installation.....	2-10
Installing an Auxiliary Relay Module (ARM-4)	
Overview	2-11
Mounting the ARM-4 Module to a CHS-4 Chassis	2-11
Wiring the ARM-4 Module.....	2-12
Connecting the MPS-400 Power Cables	
MPS-400 Electrical Connections	2-13
Connecting the MPS-400 to AC Power (TB1)	2-13
Connecting the Batteries (MPS-400, TB1-6, TB1-7)	2-13
Connecting Four-Wire Smoke Detector 24 VDC Power (MPS-400, TB2).....	2-14
Notification Appliance Power (24 VDC)	2-14
Annunciator Power (24 VDC)	2-14
System Harness Connections.....	2-14
System Power Connections	2-14
Installing Expander Row Ribbon Cables for Panel Modules	
Installing Row Ribbon Cables for ADT-CAB-B3 – ADT-CAB-D3 Cabinets	2-15
Installing Row Ribbon Cables for ADT-CAB-C3 and ADT-CAB-D3 Cabinets	2-16
Installing Row Ribbon Cables for an ADT-CAB-400AA Cabinet.....	2-17
Installing the CPU	
Installing the CPU into a Chassis.....	2-18

Connecting the CPU to the MPS-400	2-19
Mounting Expander Modules (CRE-4, ICE-4, VCE-4)	2-20
Mounting Panel Modules (CRM-4, ICM-4, VCM-4) onto a Chassis.....	2-21
Installing a 4XTM Module (Remote Station Fire Alarm)	
Mounting the Module.....	2-22
4XTM Electrical Requirements	2-22
Connecting the 4XTM Module	2-23
Installing an ADT-UZC-256 Module	
Overview	2-24
ADT-CAB-X3 Installation	2-24
ADT-CAB-400AA Installation.....	2-24
Field-Wiring the Modules	
Notification Appliance Circuit (NAC) Wiring	2-25
MPS-400/ICM-4 NAC Configurations	2-25
Typical Power Supply/Notification Appliance Circuit Configurations.....	2-25
AVPS-24/ICM-4 NAC Configurations	2-26
Field-Wiring an ICM-4 and an ICE-4 (NFPA Style Y and Z).....	2-27
Field-Wiring a CRM-4 and the CRE-4	2-28
CRM-4 and CRE-4 Wiring Guidelines.....	2-28
CRM-4 and CRE-4 Connections	2-28
Field Wiring an Optional AVPS-24 Power Supply	2-29
AVPS-24 Wiring Overview	2-29
AVPS-24 Wiring Diagrams	2-29
Field Wiring Four-Wire Smoke Detectors (Style B and Style D)	2-30
Field Wiring Overview	2-30
Field Wiring (Style D)	2-30
Field Wiring (Style B)	2-30
Field Wiring the Auxiliary Relay Module (ARM-4)	2-31
Overview.....	2-31
ARM-4 Terminal Assignments.....	2-31
Field Wiring the MPS-400 Power Supply	2-32
MPS-400 Board	2-32
DC Power Output Connections (MPS-400).....	2-33
AC and Battery Power Connections (MPS-400)	2-33
Wiring MPS-400 Output Circuits	2-34
Installing Remote Printers and CRTs	
Remote Printers.....	2-35
Setting PRN-4 Options.....	2-35
Installing a PRN-4 Remote Printer	2-36
Installing a Keltron Printer	2-37
Setting up the Keltron Printer	2-37
Installing a CRT-2.....	2-38
Connecting Multiple Printers, CRTs, or CRT/PRN Combination.....	2-38
Wiring a Signaling Line Circuit (SLC)	
Overview of SLC Wiring	2-39
SLC Devices.....	2-40
Control Panel Capacity	2-40
SLC Performance	2-41
SLC Shield Termination	2-42
Wire Requirements for a Two-Wire SLC	2-43
Measuring Loop Resistance for a Two-Wire SLC	2-43
Measuring Total Wire Length for a Two-wire SLC	2-43
Wire Requirements for a Four-Wire SLC	2-45
Measuring Loop Resistance for a Four-Wire SLC	2-45
Measuring Total Wire Length for a Four-wire SLC.....	2-45
Style 6 Wiring Overview	2-46

Style 6 Wiring Diagram	2-46
Style 7 Wiring Overview	2-47
Style 7 Wiring Diagram	2-47
Wiring an Isolator Module (M500X)	2-48
M500X Overview	2-48
Isolating a Branch of a Two-Wire SLC	2-48
Wiring an IDC with M500M Modules	2-49
Overview of Monitor Modules (M500M Series)	2-49
Wiring an M500M Module	2-49
Wiring an NFPA Style B IDC with M500Ms	2-50
Wiring an NFPA Style B IDC with M502Ms	2-51
Wiring an NFPA Style B IDC with M500Ms	2-52
Wiring a NFPA Style D IDC with M502M Modules	2-53
Wiring a Notification Appliance Circuit (NAC) or Control Circuit	2-54
M500CH Module Overview	2-54
Testing an M500CH Module	2-54
Installing an M500CH as a Form-C Relay	2-55
SLC Wiring with M500CH Modules	2-55
Style Y NAC Circuits (Two-Wire)	2-56
Wiring Diagram and Instructions	2-56
Style Z NAC	2-57
Style Z NAC Circuits (Method 1 – MPS-400 powers M500CH)	2-58
Style Z NAC Circuits (Method 2 – MPS-400 powers M500CH)	2-59
SLC Wiring with an Intelligent Detector	2-60
Overview for Wiring Intelligent Detectors	2-60
Wiring a B501B Detector to an SLC Loop	2-60
SLC Wiring with an ADT-BGX-101L Addressable Manual Pull Station	2-61
ADT-BGX-101L Overview	2-61
ADT-BGX-101L Wiring Connections	2-61
3. Testing the System	
Acceptance Test	3-1
Periodic Testing and Service	3-1
Operational Checks	3-1
Test Modes	
Walk Test Mode	3-2
Live Test Mode	3-3
Battery Checks and Maintenance	3-4
4. Voice Alarm System	
Section Overview	4-1
Installing an AMG	
Configuring the AMG	4-4
AMG-1 and AMG-E Tone/Message Selections (SW2=Off)	4-5
AMG-1 and AMG-E Tone/Message Selections (SW2=On)	4-6
ATG-2 Terminal Connections	4-7
Installing a Fire Fighter’s Telephone (FFT-7 and FFT-7S)	
Overview	4-8
Mounting an FFT-7/FFT-7S	4-8
Connecting an FFT-7/FFT-7S	4-9
Installing Audio Amplifiers (AA-30/AA-100/AA-120)	
Installing an AA-30	4-10
Overview	4-10
Mounting an AA-30	4-10
AA-30 Terminals and Connectors	4-11
Installing an AA-100/AA-120	4-12
Overview	4-12

Mounting an AA-100/AA-120.....	4-12
AA-100/AA-120 Terminals and Connectors	4-13
Installing a Backup Amplifier	4-14
Overview	4-14
Typical Installation Drawing	4-14
Voice Alarm Modules	
Overview	4-15
Module Descriptions	4-15
Connecting VCM-4 Speaker Circuits	4-16
Overview	4-16
VCM-4 Speaker Wiring Diagram	4-16
Connecting VCM-4 Telephone Circuits	4-17
Wiring Diagram	4-17
Setting the VCM-4 to Speaker or Telephone Mode	4-18
Connecting a M500CH Module to Speaker Circuits	4-18
Connecting Dual Channel Module Circuits	4-19
Wiring Notes	4-19
Wiring Diagram	4-19
Voice System Configurations	
Voice Systems Wiring Overview	4-20
Internal Power Distribution	4-21
Wiring Diagram	4-21
Block Diagram	4-21
CPU EIA-485 Connections	4-22
Wiring Diagram	4-22
Block Diagram	4-22
Wiring an Audio Signal without a Backup Amplifier	4-23
Wiring Notes	4-23
Typical Wiring Diagram	4-23
Block Diagram	4-23
Audio Signal Wiring Using a Backup Amplifier	4-24
Wiring Notes	4-24
Wiring Diagram	4-24
Block Diagrams	4-24
CPU Trouble Bus Connections	4-25
Wiring Notes	4-25
Wiring Diagram	4-25
Block Diagram	4-25
Wiring Speaker Circuits	
Wiring Speaker Circuit Overview	4-26
30 Watt/Four and Eight Speaker Circuits	4-27
Wiring Notes	4-27
Wiring Four Speakers	4-27
Wiring Eight Speakers	4-27
120 Watt/Four and Eight Speaker Circuits	4-28
Wiring Notes	4-28
Wiring Four Speakers	4-28
Wiring Four Speakers	4-28
90 Watt/Eight Speaker Circuit Configuration	4-29
Wiring Notes	4-29
Wiring Diagram	4-29
240 Watt/Eight Speaker Circuit	4-30
Wiring Notes	4-30
Wiring Diagram	4-30
180 Watt/Eight Speaker Circuit Configuration	4-31
Wiring Notes	4-31

Wiring Diagram	4-31
30 Watt Dual-Channel Configuration	4-32
Wiring Notes	4-32
Wiring Diagram	4-32
120 Watt Dual-Channel Configuration (Four AA-30s)	4-33
Wiring Notes	4-33
Wiring Diagram	4-33
120 Watt Dual-Channel Configuration (Two AA-120s)	4-34
Wiring Notes	4-34
Wiring Diagram	4-34
Voice Message Options (VROM and VRAM)	
Overview of VROM and VRAM	4-35
Installing VROM and VRAM	4-35
ACT-1 Audio Coupling Transformer	
ACT-1 Overview	4-36
Isolating Power Supplies	4-36
ACT-1 Installation	4-37
Installation Notes	4-37
Installation Diagram	4-37
Connecting the ACT-1	4-37
5. Applications	
Applications Overview	5-1
Central or Remote Station Fire Alarm System (UDACT)	
Installation	5-2
Wiring Diagram	5-2
Auxiliary Fire Alarm System	
Overview	5-3
Wiring Diagram	5-3
NFPA 72-1993 Remote Station Fire Alarm System	
Overview	5-4
Wiring Diagram	5-4
ADT Network Interface Board (ADT-NIB-96)	
ADT-NIB-96 Overview	5-5
ADT-NIB-96 Assembly	5-5
ADT-NIB-96 SLC and EIA-485 Connections	5-6
Wiring Specifications	5-6
Using the XP Transponder with the Unimode 400	
XP Transponder Overview	5-7
Wiring Diagram	5-7
Combination Fire/Security Applications/Security Applications	
Overview	5-8
General Operation	5-8
Installing a Security Tamper Switch	5-8
Installing a Security Tamper Switch into the ADT-CAB-400AA	5-8
Installing a Security Tamper Switch into the ADT-CAB-X3	5-9
Programming	5-9
Wiring for Proprietary Security Alarm Applications	5-10
Universal Zone Coder (ADT-UZC-256)	
ADT-UZC-256 Description	5-11
ADT-UZC-256 Connectors and Indicators	5-11
NAC and EIA-485 Power Connections	5-12
ADT-UZC-256 Electrical Connections	5-13
Wiring Diagram	5-13
Wiring 12 Zone-Coded NACs	5-14
Wiring 20 Zone-Coded NACs	5-15

Releasing Applications

Overview	5-16
Programming Releasing Applications.....	5-16
Wiring for Releasing Applications.....	5-16
Connecting a Releasing Device to the MPS-400	5-17
Overview.....	5-17
Typical Connections	5-17
Connecting a Releasing Device to an ICM-4/ICE-4 Module	5-18
Overview.....	5-18
Typical Connections	5-18
Connecting a Releasing Device to an M500CH Module	5-19
Overview.....	5-19
Typical Connections	5-19
Connecting an N-ARA-10 Agent Release-Abort Station	5-20
Overview.....	5-20
Typical Connections	5-20
Installing a Combination Waterflow/Supervisory Valve Monitor.....	5-21
Overview.....	5-21
Typical Connections	5-21

Appendix A: Annunciators

Overview	A-1
Annunciator Interfaces	
Terminal Mode (ADT-LCD-80)	A-1
ACS Mode.....	A-1
Annunciator Selection Groups	
Overview	A-2
ACS Annunciator Selection Group 1	A-3
ACS Annunciator Selection Group 2	A-4
ACS Annunciator Selection Group 3	A-5
ACS Annunciator Selection Group 4	A-6
ACS Annunciator Selection Group 5	A-7
ACS Annunciator Selection Group 6	A-8
ACS Annunciator Selection Group 7	A-9
ACS Annunciator Selection Group 8	A-10
ACS Annunciator Selection Group 9	A-11
Connecting Annunciators	
Overview	A-12
ADT-LCD-80 Terminal Mode EIA-485 Connection (CPU, TB3).....	A-13
Connection Guidelines.....	A-13
Connecting ADT-LCD-80s in Terminal Mode.....	A-13
ADT-LCD-80 ACS Mode EIA-485 Connection (CPU, TB4).....	A-14
Connection Guidelines.....	A-14
Connecting ADT-LCD-80s in ACS Mode	A-14
Powering ADT ACS-, LDM-, ACM-, and LCD-type Annunciators	A-15
Overview.....	A-15
Power Connections	A-15
Power Connections for ADT-LCD-80 Annunciators	A-15
ADT-ACS and ADT-LDM Series EIA-485 Connection	A-16
Connection Guidelines.....	A-16
EIA-485 Connections	A-16

Appendix B: Wire Requirements**Appendix C: Compatible Equipment**

Appendix D: CRT-2 Configuration

Overview	D-1
Setting CRT-2 Parameters.....	D-1
Uploading or Downloading the Operating Program	D-2

Appendix E: Terminal Interface Protocol

General Description	E-1
Operating Modes	
Local Terminal Mode (LocT)	E-1
Local Monitor Mode (LocM).....	E-2
Remote Terminal Mode (RemT)	E-3
Using the CRT-2 for Read Status	
Overview	E-4
Accessing Read Status Options.....	E-4
Read Point	E-5
Display Devices in Alarm or Trouble	E-5
Display the Status of all Programmed Points.....	E-5
View the History Buffer.....	E-6
Send the History Buffer to the CRT-2	E-6
Using the CRT-2 for Alter Status	
Overview	E-7
Accessing Alter Status Options.....	E-7
Enable or Disable Detectors, Modules, or Panel Circuits	E-8
Change Alarm and Pre-Alarm levels	E-9
Clear the Verification Counter	E-9
Clear the Entire History Buffer	E-9
Set the Pre-Alarm for Alert or Action.....	E-9

Appendix F: UL Power-limited Wiring Requirements

Overview	F-1
Power-limited Modules and Circuits	
UL Power-limited Wiring Requirements	F-2
Power Supply Wiring	F-3

Appendix G: Power Supply Calculations

Overview	G-1
Calculating AC Branch Circuit Current	G-1
Calculating the System Current Draws	G-1
How to Use Table G-2	G-2
Calculating the Maximum Secondary Power Fire Alarm Current Draw	G-4
Calculating the Battery Requirements	G-5
Calculating the Battery Capacity	G-5
Calculating the Battery Size.....	G-5

Standards and Other Documents

Standards

This Fire Alarm Control Panel complies with the following NFPA standards:



NFPA 12 CO2 Extinguishing Systems
 NFPA 12A Halon 1301 Extinguishing Systems
 NFPA 12B Halon 1211 Extinguishing Systems
 NFPA 13 Sprinkler Systems
 NFPA 15 Water Spray Systems
 NFPA 16 Foam/Water Deluge and Foam/Water Spray Systems
 NFPA 17 Dry Chemical Extinguishing Systems
 NFPA 17A Wet Chemical Extinguishing Systems
 NFPA 72-1993 Central Station Fire Alarm Systems (Automatic, Manual and Waterflow) Protected Premises Unit (requires UDACT).
 NFPA 72-1993 Local (Automatic, Manual, Waterflow and Sprinkler Supervisory) Fire Alarm Systems.
 NFPA 72-1993 Auxiliary (Automatic, Manual and Waterflow) Fire Alarm Systems (requires 4XTM).
 NFPA 72-1993 Remote Station (Automatic, Manual and Waterflow) Fire Alarm Systems (requires 4XTM or NOTI-FIRE 911A DACT).
 NFPA 2001 Clean Agent Fire Extinguishing Systems

The installer should be familiar with the following documents and standards:



NFPA 72-1993 Initiating Devices for Fire Alarm Systems
 NFPA 72-1993 Inspection, Testing and Maintenance for Fire Alarm Systems
 NFPA 72-1993 Notification Appliances for Fire Alarm Systems

Underwriters Laboratories

UL 38 Manually Actuated Signaling Boxes
 UL 217 Smoke Detectors, Single and Multiple Station
 UL 228 Door Closers - Holders for Fire Protective Signaling Systems
 UL 268 Smoke Detectors for Fire Protective Signaling Systems
 UL 268A Smoke Detectors for Duct Applications
 UL 346 Waterflow Indicators for Fire Protective Signaling Systems
 UL 464 Audible Signaling Appliances
 UL 521 Heat Detectors for Fire Protective Signaling Systems
 UL 864 Standard for Control Units for Fire Protective Signaling Systems
 UL 1481 Power Supplies for Fire Protective Signaling Systems
 UL 1971 Visual Signaling Appliances
 UL 1076 Proprietary Burglar Alarm Systems

Other

EIA-485 and EIA-232 Serial Interface Standards
 NEC Article 300 Wiring Methods
 NEC Article 760 Fire Protective Signaling Systems
 Applicable Local and State Building Codes
 Requirements of the Local Authority Having Jurisdiction

Other Documents

Table 1 contains a list of other documents that are related to the control panel:

Document Title	Document Number
The ADT-LDM Series Annunciator	A15885
The ADT-LCD-80 Liquid Crystal Display	A15037
The Device Compatibility Document	A15378
The ADT-NIB-96 Network Interface Board	A15666
The ADT-ACM-8R Annunciator Control Module	A15342
The ADT-ACS Series Annunciators	A15843
Unimode 400 Operations Manual	50709
Unimode 400 Programming Manual	50708
Unimode 400 Basic System Connections	50712
The ADT-AFM-16A Annunciator	A15207
Uni•Tility 400 Product Installation Document	50768
The UDACT Manual	50050

Table 1 Unimode 400 Related Documents

Compatible Equipment

This section lists ADT, Notifier, and System Sensor equipment that is compatible with the control panel. Also, refer to the Device Compatibility Document for compatible equipment.

ADT Compatible Equipment

Table 2 contains a list of ADT equipment that is compatible with the control panel:

ADT-ABF-1 Annunciator Flush Box ADT-ABF-1D Annunciator Flush Box with Door ADT-ABF-2 Annunciator Flush Box ADT-ABF-2D Annunciator Flush Box with Door ADT-ABF-4 Annunciator Flush Box ADT-ABF-4D Annunciator Flush Box with Door ABM-16AT Annunciator Blank Module ABM-32A Annunciator Module Blank ADT-ABS-1T Annunciator Surface Box ADT-ABS-2 Annunciator Surface Box ADT-ABS-8R Annunciator Backbox for ACM-8R ADT-ACM-16AT Annunciator Control Module ADT-ACM-32A Annunciator Control Module ADT-ACM-8R Annunciator Control Module ADP-4 Annunciator Dress Panel AEM-16AT Annunciator Expander Module AEM-32A Annunciator Expander Module ADT-AFM-16A Annunciator Fixed Module ADT-AFM-16AT Annunciator Fixed Module ADT-AFM-32A Annunciator Fixed Module ADT-AKS-1 Annunciator Key Switch ARM-4 Auxiliary Relay Module ADT-BGX-101L Addressable manual pull station ADT-CAB-A3 A-size cabinet ADT-CAB-B3 B-size cabinet ADT-CAB-C3 C-size cabinet ADT-CAB-D3 D-size cabinet	ADT-CAB-400AA AA-size cabinet ADT-DR-AA/DR-400AA AA-size Door ADT-DR-A3 A-size Door ADT-DR-B3 B-size Door ADT-DR-C3 C-size Door ADT-DR-D3 D-size Door BM-1 Blank Module BP-3 Battery Dress Panel CHS-4L Chassis CHS-4M Chassis ADT-CPU-400 CPU for Unimode 400 CRE-4 Control Relay Expander CRM-4 Control Relay Module DCM-4 Dual Channel Module ADT-DP-400AA Dress Panel for ADT-CAB-AA DP-1 Dress Panel DPDW-1 Double Well Dress Panel DPSW-1 Single Well Dress Panel FPJ Fireman's Phone Jack ICE-4 Indicating Control Expander ICM-4 Indicating Control Module ADT-LCD-80 Liquid Crystal Display Module LCD-80TM Terminal Mode LCD Annunciator ADT-LDM-32 Lamp Driver Module LDM-E32 Lamp Driver Module LDM-R32 Lamp Driver Module ADT-NIB-96 Network Interface Board V54095 Keltron Printer RPJ-1 Fireman's Phone Jack ADT-UZC-256 Universal Zone Coder UNI•TILITY Off-line Programming Kit VCE-4 Voice Control Expander VCM-4 Voice Control Module
--	---

Table 2 ADT Compatible Equipment

Notifier Compatible Equipment

Table 3 contains a list of Notifier equipment that is compatible with the control panel:

4XTM Transmitter Module AA-30 30-Watt Audio Amplifier AA-100 100-Watt Audio Amplifier AA-120 120-Watt Audio Amplifier ACT-1 Audio Coupling Transformer AMG-1 Audio Message Generator AMG-E Audio Message Generator ATG-2 Audio Tone Generator AVPS-24 Audio/Visual Power Supply BB-17 Battery Box BB-55 Battery Box CHG-120 Battery Charger CRT-2 Video Display Monitor with Keyboard FCPS-24 Field Charger Power Supply FFT-7 Fire Fighters Telephone FFT-7S Fire Fighters Telephone FHS Fireman's Handset L20-300-BX Enclosure; recessed mount L20-310-BX Enclosure; surface mount N-ARA-10 Agent Release pull station N-ELR Assortment ELR pack with mounting plate PRN-4 80-Column Printer PS-12120 Battery 12-volt, 12 amp-hour	PS-12170 Battery 12-volt, 17 amp-hour PS-12250 Battery 12-volt, 25 amp-hour PS-12550 Battery 12-volt, 55 amp-hour SBB-A3 A-size Backbox SBB-B3 B-size Backbox SBB-C3 C-size Backbox SBB-D3 D-size Backbox STS-200 Security Tamper Switch for ADT-CAB-400AA R-120 120 Ohm End-of-Line Resistor R-2.2K 2.2K End-of-Line Resistor R-27K 27K End-of-Line Resistor R-470 470 End-of-Line Resistor R-47K 47K End-of-Line Resistor RPT-485F EIA-485 Repeater (Fiber) RPT-485W EIA-485 Repeater (Wire) RPT-485WF EIA-485 Repeater (Wire/Fiber) TR-500 Trim Ring for ADT-CAB-400AA UDACT Universal Digital Alarm Communicator Transmitter XPC-8 Transponder Control Module XPDP Transponder Dress Panel XPM-8 Transponder Monitor Module XPM-8L Transponder Monitor Module XPP-1 Transponder Processor XPR-8 Transponder Relay Module
---	---

Table 3 Notifier Compatible Equipment

System Sensor Compatible Equipment

Table 4 contains a list of System Sensor equipment that is compatible with the control panel:

1251 Intelligent Ionization Smoke Detector 1551 Intelligent Ionization Smoke Detector 2551 Intelligent Photoelectric Detector 2551TH Intelligent Photoelectric Detector 2251 Intelligent Photoelectric Detector 3251 Advanced Multi-Sensor Intelligent Detector A2143-00 End of Line Resistor Assembly B501B detector base B501BH Sounder detector base B524BI Isolator detector base	B524RB Relay detector base DH500/DH502 Duct detector M500X Loop Fault Isolator Module M500CH Addressable Control Module M500M Addressable Monitor Module M501M Addressable Mini Monitor Module M502M Addressable Monitor Module RA400 Remote Annunciator RA400Z Remote Annunciator with LED
--	--

Table 4 System Sensor Compatible Equipment

1. System Overview

Introduction

Note: Throughout this manual, “control panel” refers to a Unimode 400 Multi-Net control panel, and CPU refers to an ADT-CPU-400.

About this Manual

This manual contains information for designing, installing, and testing the Unimode 400 Multi-Net Fire Alarm Control Panel and fire alarm system components. Table 1-1 contains a list of document sources for supplemental information:

For information on...	Refer to...	Part Number
All features	Unimode 400 Data Sheet	DN-5871
Programming	Unimode 400 Multi-Net Programming Manual	50708
Operation	Unimode 400 Multi-Net Operations Manual	50709
Compatible Devices	Device Compatibility Document	A15378
System Connections	Unimode 400 Multi-Net Basic System Drawing	50712

Table 1-1 Supplemental Documentation

Description

The Unimode 400 control panel is a modular, intelligent fire alarm control panel (FACP) with an extensive list of powerful features. The ADT-CPU module, power supply module, mounting chassis, and cabinet combine to create a complete fire alarm control system with optional voice and telephone and advanced networking. Optional modules mount to the chassis to provide additional output circuits.

The Unimode 400 has the capacity for installing up to 464 intelligent, addressable devices (198 analog detectors and 198 monitor/control modules, and up to 68 internal circuits/relays). Five cabinet options for the Unimode 400 (ADT-CAB-400AA, ADT-CAB-A3, ADT-CAB-B3, ADT-CAB-C3, or ADT-CAB-D3) for enclosing system components.

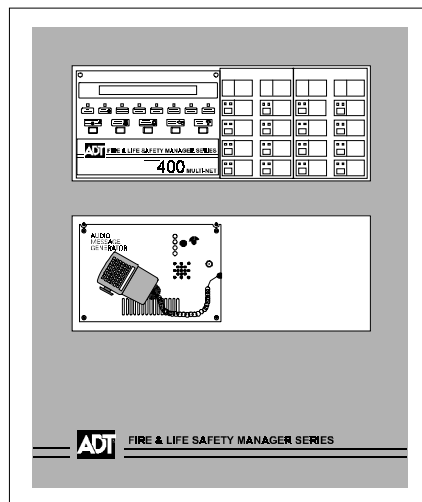

Standard Features and Options

Control panel features and options that affect installation include:

- Four Notification Appliance Circuit (NAC) bell circuits standard, expandable to 68 total (Class A or B).
- EIA-485 connections for wiring ACS annunciators (including ADT-LDM custom graphic annunciators).
- Optional modules include: 4XTM transmitter, UDACT Universal Digital Alarm Communicator/Transmitter, ADT-ACM-8R remote relay module to increase point capacity, and audio and voice components.
- Autoprogram feature for faster programming of new devices.
- Optional ADT-LCD-80 allows monitoring and controlling the system—up to 6,000 feet from the control panel.

The control panel provides 6.0 amps of usable output power (standard).

System Limitations

System expansion must comply with:

1. The physical limitations of the cabinet configuration.
2. The electrical limitations of the system power supply, including auxiliary power supplies used for notification appliances.
3. The capacity of the Secondary Power Source (standby batteries).

Refer to System Components, for descriptions of the various optional modules. Refer to Section 2, *Installation* for installation information.

System Diagram

Figure 1-1 shows a Unimode 400 Multi-Net system installed in an ADT-CAB-C3 with a voice alarm system and a full complement of installed devices.

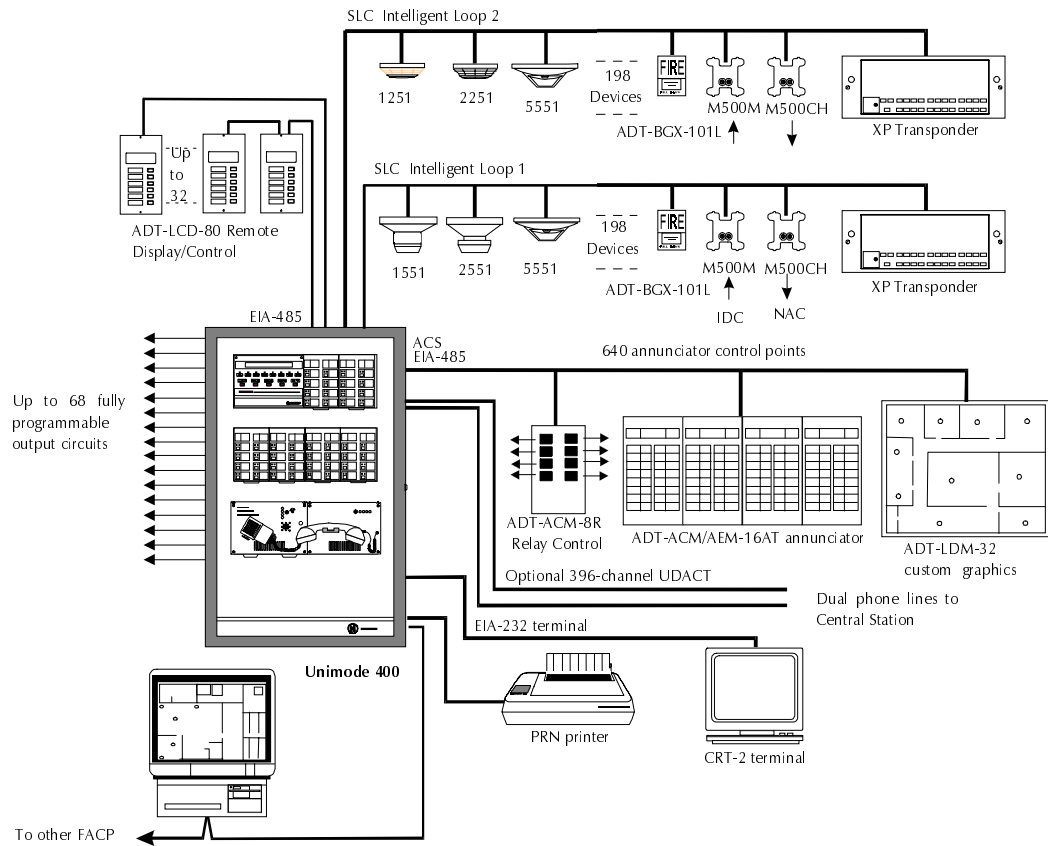

Figure 1-1 Unimode 400 Multi-Net System Diagram

Specifications

Overview

This section contains electrical specifications for the control panel.

AC Power

Component	Values
MPS-400	120 VAC, 50/60 Hz, 3.0 A; or 240 VAC, 50/60 Hz, 1.5 A
AVPS-24	120 VAC, 1.0 A each
AA-30	120 VAC, 1.0 A each
AA-100/AA120	120 VAC, 50/60 Hz, 1.85 A each
Wire size	Minimum 14 AWG with 600 VAC insulation

Table 1-2 AC Power

Battery (sealed lead-acid only)

Table 1-3 contains specifications for batteries that can be used with the control panel:

Battery Charger (MPS-400)	Dual Rate: High Charge Normal Flat Charge Charging Current	29.1 VDC 27.6 VDC 2.0 A maximum 1.5 A typical
Maximum Battery Capacity (MPS-400)	55 AH (Batteries larger than 25 AH requires BB-55 or other UL-listed battery cabinet.)	
	ADT-CAB-400AA ADT-CAB-A3 through ADT-CAB-D3	12 AH (17 AH with BB-17) 25 AH (55 AH with BB-55)

Table 1-3 Battery Specifications

Signaling Line Circuit (SLC) Loop

Table 1-4 contains specifications for an SLC:

Note: Refer to Appendix B for Wire Requirements.

Item	Value
Voltage	24 VDC nominal, 27.6 VDC maximum
Maximum length	10,000 ft. per channel (NFPA Style 4) or 10,000 ft. total loop length (NFPA Style 6 and 7)
Maximum loop current	250 mA (maximum short circuit) or 100 mA (normal)
Maximum loop resistance	40 ohms (supervised and power-limited)

Table 1-4 SLC Specifications

Notification Appliance and Releasing Circuits (MPS-400 ICM-4, ICE-4)

Table 1-5 contains specifications for NACs and releasing circuits available on the MPS-400:

Item	Value
Maximum wiring voltage drop	2 VDC (except M500CH which is 1.2 VDC)
Normal operating voltage	24 VDC
Current for all external devices connected to MPS-400	6.0 A (except devices powered from the AVPS-24 or AA-30 and AA-120, or FCPS-24)
Optional AVPS-24	Additional 3.0 A of NAC power for each AVPS-24 (requires ICM-4 modules)
Maximum signaling current/circuit (MPS-400)	2.5 A (except M500CH which is 2 A)
End-of-line resistors	MPS-400 (TB-7–TB-10): 2.2K, 1/2 watt ICM-4, ICE-4, VCM-4, CE-4, and DCM-4: 4.7K, 1/2 watt (2 watts on 70 Vrms audio) M500CH Modules: 47K, 1/2 watt

Table 1-5 NACs and Releasing Circuits

Relays

Relays for Alarm, Trouble, Security, and Supervisory are available on MPS-400 terminals TB3 to TB6. Contact ratings for TB3-TB6 are:

- 2.0 A @ 30 VDC (resistive);
- 0.5 A 30 VAC (resistive) when used for a Form-C relay.

Four-wire Smoke Detector Power

Note: The MPS-400 provides a total of 6.0 A of power, shared by all internal modules and each MPS-400 circuit. For power requirements, refer to the power supply calculation tables in Appendix G.

MPS-400 terminals TB2-5 (+) and TB2-6 (–) supply filtered, resettable, low-noise power for four-wire smoke detectors. Specifications for TB2-5 and TB2-6 are:

- Maximum ripple voltage: 10 mVrms
- Up to 1.25 A is available for powering four-wire smoke detectors.

For 24 VDC detectors, refer to the Device Compatibility Document for compatible detectors.

Note: The MPS-400 provides a total of 6.0 A of power, shared by all internal modules and each MPS-400 circuit. For power requirements, refer to the power supply calculation tables in Appendix G.

Power Outputs

There are two power-limited circuits available to power external devices, such as notification appliances and annunciators. Refer to the Device Compatibility Document for compatible devices and notification appliances.

Item	Circuit A	Circuit B
Terminals	TB2-1 (+) and TB2-2 (-)	TB2-3 (+) and TB2-4 (-)
Nominal Voltage	24 VDC	24 VDC
Max rated current	1.25 A DC	1.25 A DC
Max ripple voltage	100 mVrms	100 mVrms

Table 1-6 Power-Limited Circuits

Operating Power

AC Branch Circuit

This control panel requires connection to a separate dedicated AC branch circuit. Follow these guidelines when connecting the AC branch circuit:

- Label the branch circuit “Fire Alarm”.
- Connect the branch circuit to the line side of the main power feed of the protected premises.
- Do not power other equipment from the fire alarm branch circuit.
- Run the branch circuit wire continuously, without any disconnect devices, from the power source to the fire alarm control panel.
- Overcurrent protection for this circuit must comply with Article 760 of the National Electrical Codes, as well as local codes.
- Use 14 AWG wire with 600 VAC insulation for this branch circuit.

Connect the earth ground terminal (MPS-400, TB1-3) to a solid earth ground (a metallic, cold water pipe may be suitable in some installations). This connection is vital to maintaining the control panel's immunity to unwanted transients generated by lightning and electrostatic discharge.

Secondary Power Source (Batteries)

The battery charger is current-limited and can recharge sealed lead-acid type batteries. The charger shuts off when the control panel is in alarm.

System Components

Basic Equipment Packages

Basic Equipment packages for the Unimode 400 include the following:

- ADT-BE-400 – Base Equipment includes the ADT-CPU-400 module, an MPS-400 power supply, a BP-3 Battery Plate, cables, manuals, and a first row chassis. Order ADT-CAB-X3 cabinets separately.
- ADT-BE-400AA – Base Equipment for an ADT-CAB-400AA mini-cabinet—similar to the ADT-BE-400—but for use in the ADT-CAB-400AA. The ADT-BE-400AA supports one output option module, and includes an MPS-400RB and transformers. Order ADT-CAB-400AA cabinets separately.

ADT-CPU

The ADT-CPU provides LED indicators and operational switches. The panel is visible with the cabinet door closed, except for programming switches, which are located behind a flip-down door.

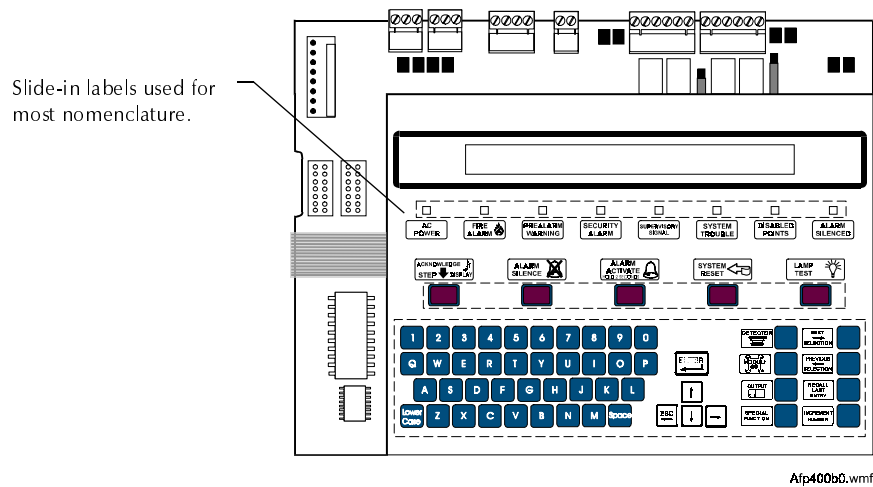

Figure 1-2 ADT-CPU Module

Power Supplies

The control panel can use two types of internally mounted power supplies: the MPS-400 main power supply and an optional Audio Visual Power Supply (AVPS-24).

MPS-400 (required). The MPS-400 supplies a total of 6 A in alarm, used for the following: (a) powering Unimode 400 modules; (b) powering a variety of standard UL-listed 24 VDC notification appliances; and (c) providing up to 1.25 A of resettable power for four-wire smoke detectors. The MPS-400 contains an integral battery charger, four NAC/Releasing circuits, and four relay outputs (Alarm, Trouble, Supervisory, and Security).

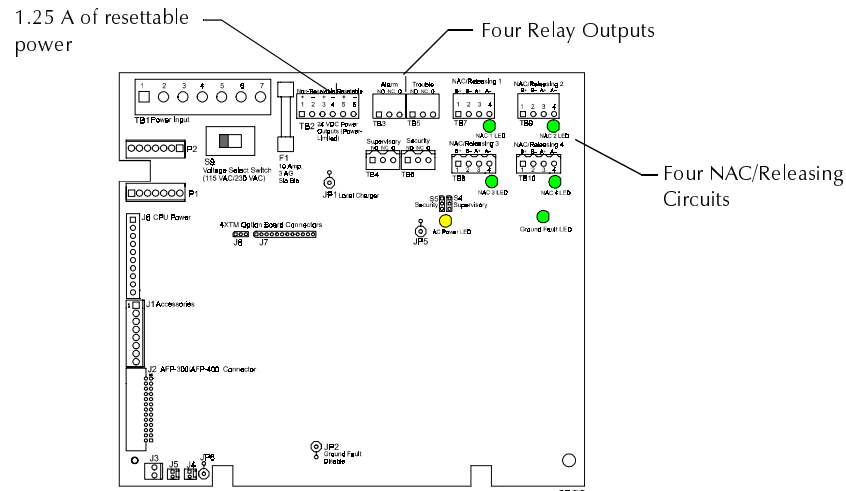

Figure 1-3 MPS-400 Power Supply

AVPS-24 (optional). The AVPS-24 Audio/Visual Power Supply provides up to 3 A of additional special purpose power (unregulated, unfiltered) for output modules. The AVPS-24 mounts to one-fourth of a CHS-4 chassis. In space-critical applications, mount an AVPS-24 under system modules on a CHS-4 chassis. Refer to the Device Compatibility Document for a list of compatible, UL-listed notification appliances.

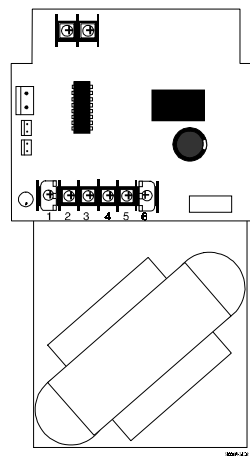

Figure 1-4 AVPS-24 Power Supply

Audio Amplifiers

The control panel uses three types of audio amplifiers with an installed Voice Alarm System: the AA-30, the AA-100, and the AA-120.

- AA-30 – The AA-30 Audio Amplifier provides up to 30 watts of audio power for driving 25 Vrms speaker circuits.
- AA-100 – The AA-100 Audio Amplifier provides 100 watts of audio power for driving 70 Vrms speakers.
- AA-120 – The AA-120 Audio Amplifier provides 120 watts of audio power for driving 25 Vrms speakers.

Each AA amplifies the audio signal coming in from an Audio Message Generator (AMG-1) or Audio Tone Generator (ATG-2).

Transformer Assembly and MPS-400RB

Two 100VA transformers and connectors are used with the MPS-400RB in the ADT-CAB-400AA.

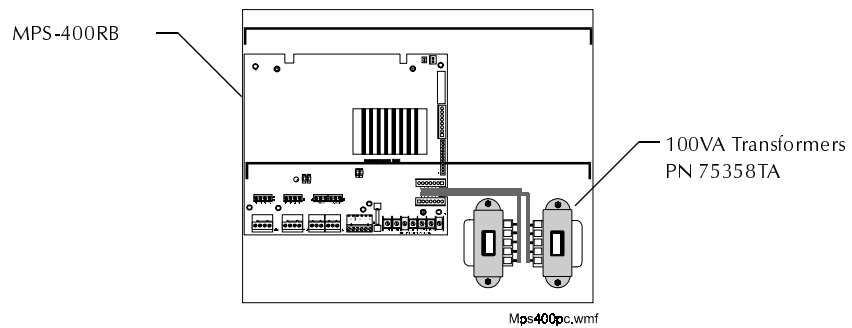

Figure 1-5 MPS-400RB Using Two 100VA Transformers

Battery Boxes

The ADT-CAB-400AA cabinet provides space for two 12 ampere-hour (AH) batteries. ADT-CAB-X3 cabinets provide space for two 25 AH (or smaller) batteries. Use external battery boxes if your installation requires larger capacity batteries. Battery boxes mount directly below the main cabinet. Models of battery boxes are:

- BB-17 battery box – for batteries up to 17 AH.
- BB-55 battery box – for batteries up to 55 AH.

Optional Devices

Table 1-7 contains a list of optional components that can be installed in a Unimode 400 system:

Option	Description
<p>UDACT</p> 	<p>A Universal Digital Alarm Communicator/Transmitter (UDACT) transmits system status to UL-listed Central Station Receivers over a public switched telephone network. The UDACT mounts in a cabinet or mounts remotely in the ADT-ABS-8R. The UDACT connects to the EIA-485 annunciator port and 24 VDC (nominal) power.</p>
<p>4XTM Transmitter Module</p> 	<p>A 4XTM module provides municipal box and remote station transmitters meeting NFPA 72-1993 Auxiliary and Remote Station requirements. The 4XTM also includes a Disable switch and an LED indicator.</p>
<p>Trim Ring</p> 	<p>A gray trim ring is available for semi-flush mounting of the ADT-CAB-X3 Series cabinet.</p>
<p>ADT-UZC-256 Universal Zone Coder</p> 	<p>An ADT-UZC-256 module is a circuit board—used for NAC coding applications—that provides three output circuits and up to 256 zone codes.</p>
<p>ADT-NIB-96 Network Interface Board</p> 	<p>An ADT Network Interface Board (ADT-NIB-96) is a microprocessor-controlled module that connects slave control panels to a master control panel. The ADT-NIB-96 module can be installed in each slave FACP. Each slave FACP can contain as many as 96 input/output points, or as few as eight points.</p>
<p>FCPS-24 Field Charger Power Supply</p> 	<p>The FCPS-24 is a compact, cost-effective remote power supply and battery charger. This remote power supply consists of a filtered, regulated 24 VDC output that can drive up to four Notification Appliance Circuits (NACs).</p>

Table 1-7 Optional Devices for the Unimode 400

Intelligent Detectors (System Sensor)

Overview

Intelligent, addressable detectors provide analog information to the control panel. This allows the control panel to continually process this information to determine the status of each detector (alarm, trouble, maintenance, or normal). Each detector responds to an address that is set in the detector head using built-in rotary decimal switches. You can program the sensitivity of each intelligent detector. (Refer to Appendix C in the Unimode 400 Programming Manual for details.)

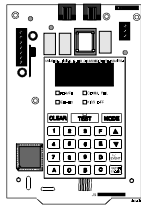
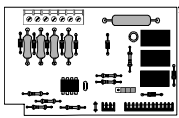
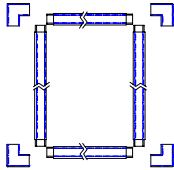
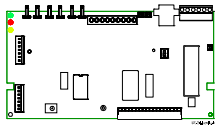
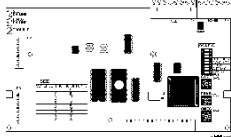
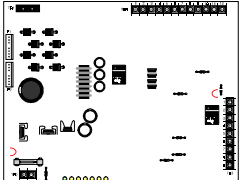
Detector Descriptions

Table 1-8 contains a list of the intelligent detectors that you can use with a Unimode 400 system:

Option	Description
B501B B210LP B501BH B524RB B524BI	Standard U.S detector base Low Profile base Sounder base Relay base Isolator base
2551/2551TH/2251	An Intelligent Photoelectric Smoke Detector provides analog measurements of the optical smoke level in its chamber to the control panel. Also available: an 2551TH with a 135° thermostat and a 2251 low profile photoelectric detector.
1551/1251	An Intelligent Ionization Smoke Detector measures the level of combustion products in its chamber using the ionization principle and reports this measurement to the control panel. Also available: a 1251 Low Profile detector. <i>When used in duct applications, the 1551 must be set to high sensitivity (AL=1). Refer to Appendix C in the Unimode 400 Programming Manual for details on setting alarm sensitivity.</i>
5551	An Intelligent Thermal Sensor (135°F fixed temperature). Also available as an 5551R which is a combination 135°F fixed and 15°F per minute rate of rise.
RA400Z	A Remote Single LED Annunciator that can be wired directly off of an addressable detector for annunciation of that detector's alarm status.
DH500/DH502	Duct Housings for the 2551 and 1551.
3251	A microprocessor-based intelligent smoke detector that uses a combination of photoelectric, ionization, and thermal sensing technologies.

Table 1-8 Intelligent Detectors

Addressable Modules (System Sensor)

Overview

M500CH Series Control Modules and M500M Series Monitor Modules provide an interface between the control panel and conventional notification (M500CH) and initiating (M500M) devices. You can set each M500CH and M500M module to respond to an address with built-in rotary decimal switches. A blinking LED on an M500M or M500CH indicates communication between the module and the control panel.

Module Descriptions

Table 1-9 contains descriptions of M500CH and M500M series modules and other addressable modules used with the control panel:

Option	Description
Monitor Modules (M500M, M502M) 	Addressable Monitor Modules for monitoring conventional initiating devices. The M500M is used for normally open contact alarm initiating devices, such as manual pull stations, four-wire smoke detectors, heat detectors, waterflow, security contacts, and supervisory devices. Use the M502M for specific two-wire smoke detectors in addition to normally open contacts. Wire supervised circuits as NFPA Style B or Style D circuits.
M501M 	An Addressable Module that is functionally similar to an M500M Monitor Module (Style B circuits only), but offered in a smaller package for mounting directly in the electrical box of the device being monitored. It does not include a blinking LED or a magnetic test switch.
Control Modules (M500CH) 	Addressable Control Modules used as Notification Appliance Circuits (NACs) to power and supervise compatible, UL-listed notification appliances. Wire supervised circuits as NFPA Style Y or Style Z. Breaking the two built-in tabs allows using the M500CH as a Form-C control relay. A M500CH comes with a thermoplastic cover for mounting to a 4-inch square mounting box.
Loop Isolator Module (M500X) 	The M500X is an automatic switch that opens the circuit voltage to a communications loop branch(es) whenever a fault is detected on that circuit. The remainder of the communications loop leading up to the M500X continues to operate, unaffected by the fault.
ADT-BGX-101L 	A dual action addressable manual pull station featuring a key-lock reset. The pull station includes an M501M and responds to an address set with built-in rotary decimal switches.

Table 1-9 Addressable Modules

End-of-Line Devices

Table 1-10 contains a list of the end-of-line devices that you can install in a Unimode 400 system:

Option	Description	Notes
A2143-00 (System Sensor)	A 47K End-Of-Line Resistor (ELR) Assembly ELR used in the supervision of M500M or M501M Monitor and M500CH Control Module circuits.	Supplied with M500M or M500CH modules.
A2143-10 (System Sensor)	The 3.9K End-Of-Line Resistor (ELR) Assembly used with the M502M.	Supplied with M502M modules.
N-ELR Resistor plate (Notifier) 	An N-ELR, required for Canadian installations, provides connection for a resistor to mount to an ELR plate.	<ul style="list-style-type: none"> • Use 2.2K for the MPS-400 output. • Use 4.7K for ICM-4, ICE-4, VCM-4, VCE-4, and DCM-4. • Use 47K for M500CH, M500M, and M501M modules.

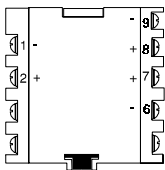
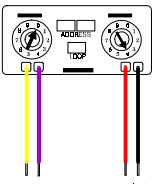
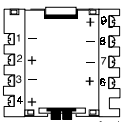
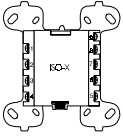
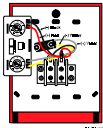
Table 1-10 End-of-Line Devices

Annunciation Modules

Overview

This section contains brief descriptions and the model numbers of annunciator modules that can be connected to the control panel. Communication between the control panel and annunciators takes place over a two-wire serial interface connected to an EIA-485 connector (TB4) on the ADT-CPU. For detailed wiring requirements, refer to the appropriate Annunciator manuals.

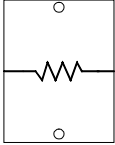
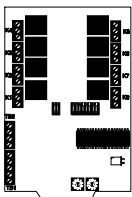

Annunciator Control Module (ADT-ACM-8R)

The ADT-ACM-8R provides the Unimode 400 with a mappable relay control module. ADT-ACM-8R relays can be selected for mapping anywhere in the system memory map (in groups of eight). Features of the ADT-ACM-8R include the following:

- Provides eight Form-C relays with 5 A contacts.
- Tracks any group of eight zones within the system.

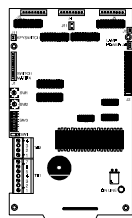

ADT-LDM Series Lamp Driver Modules

The ADT-LDM-32 Lamp Driver Annunciator Module provides 32 alarm lamp driver outputs for connection to a custom graphic annunciator. You can also set the ADT-LDM-32 with a DIP switch for 16 alarm, 16 trouble and 16 switch inputs for control of such system functions as Signal Silence and System Reset.

- Lamp Driver Annunciator Expander Module (LDM-E32) – Expands the ADT-LDM-32 by 32 system points, to a maximum of 64 points.
- Relay Expander Module (LDM-R32) – Provides the ADT-LDM-32 or LDM-E32 with 32 dry Form-A (normally open) contacts.

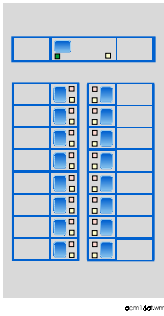

Annunciator Control System (ADT-ACS)

The ACS series annunciator and control system provides the Unimode 400 with up to 32 remote serially connected annunciators, each with a capacity of 64 points. Table 1-11 contains brief descriptions of ACS annunciators. For detailed information, refer to the ACS Manual.

Module	Features
Annunciator Control Module-16AT (ACM-16AT)	The ADT-ACM-16AT provides features for audible and visual indication of alarm and trouble conditions at each annunciator. These features include: 1) 16 red alarm LEDs; 2) 16 yellow trouble LEDs; 3) 16 momentary touch-pad switches for controlling each point; 4) a system trouble LED; 5) an On-line/Power LED; 6) a local sounder; 7) a Silence/Acknowledge switch; and remote functions.
Annunciator Expander Module (AEM-16AT)	The AEM-16AT, identical in size and appearance to the ACM-16AT, expands the ADT-ACM-16AT by 16 system points. An ADT-ACM-16AT can support up to three AEM-16ATs, to provide a maximum of 64 system points. Note: An AEM-16AT cannot be used to expand an ACM-32A.
Annunciator Control Module-32AT (ADT-ACM-32A)	The ADT-ACM-32A provides features for audible and visual indication of alarm and trouble conditions at each annunciator. These features include: 1) 32 red alarm LEDs; 2) a system trouble LED; 3) an On-line/Power LED; 4) a local sounder; and 5) a Silence/Acknowledge switch.
Annunciator Expander Module-32A (AEM-32A)	The AEM-32A, identical in size and appearance to the ADT-ACM-32A, expands the ADT-ACM-32A by 32 system points. An ADT-ACM-32A can support one AEM-32A, providing a maximum of 64 system points. Note: An AEM-32A cannot be used to expand an ADT-ACM-16AT.

Table 1-11 ADT-ACM-16AT/ADT-ACM-32A Modules

Annunciator Fixed Modules

Annunciator Fixed Modules (ADT-AFM-16AT and ADT-AFM-32A) provide the control panel with discrete display and control points. ADT-AFMs turn their LEDs on and off as directed by the CPU, and also report switch activations to the CPU for action. You can only use one ADT-AFM in a system. Each annunciator's address is fixed at address 1.

- ADT-AFM-16AT – The ADT-AFM-16AT contains 16 red alarm and 16 yellow trouble LEDs, a system trouble LED, an On-line/Power LED, and a local sounder, and switches for control panel Acknowledge, Alarm Silence, and System Reset. Use the ADT-AFM-16AT for systems that require 16 or fewer annunciation points.
- ADT-AFM-32A – The ADT-AFM-32A contains 32 red alarm LEDs, a system trouble LED, an ON LINE/POWER LED, and a local panel sounder with a silence/acknowledge switch. The ADT-AFM-32A is fixed at address 1, and will not accept expander modules.

Peripheral Displays and Printers

Overview

The control panel is compatible with the following printers and display devices:

- ADT-LCD-80 display
- PRN-4 printer
- Keltron Remote Printer
- CRT-2 Display Terminal

For installation instructions for these devices, refer to Section 2.

ADT-LCD-80 Display

The ADT-LCD-80 alphanumeric display module is a Unimode 400 ancillary device that acts as an alphanumeric annunciator. The ADT-LCD-80 features the following:

- 80-character liquid crystal display that backlights under normal and alarm conditions.
- Control switches for Acknowledge, Signal Silence, and System Reset, all made operational by an optional ADT-AKS-1 switch.
- Time/date display field.
- Annunciator backbox ADT-ABF-1 package with optional ADT-AKS-1 key switch and phone jack options.
- Remote operation (mounts up to 6,000 feet from the control panel).
- Local panel sounder with alarm/trouble resound.

PRN-4 Remote Printer

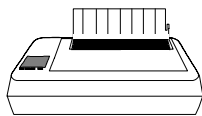

The PRN-4 is an optional printer that connects directly to the control panel through TB1 on the CPU and can be located up to 50 feet from the control panel. It features the following:

- Provides a printed record (80 columns of data on standard 9" x 11" tractor-feed paper) of all system events (alarm, trouble) and status changes within the system.
- Time-stamps the printout with the current time-of-day and date.

Keltron Remote Printer (Model VS4095)

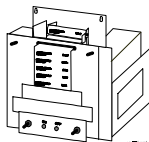

The VS4095 is a two-color (red/black), 40-column 24 VDC that can print 50 messages in 90 seconds. This printer connects to the control panel through TB1 on the CPU and mounts in a separate cabinet next to the control panel. The VS4095 meets UL fire and security requirements for an ancillary device. For more information on the Keltron printer, contact the manufacturer (Keltron Corp., Waltham, MA). Refer to Section 2 for installation instructions.

CRT-2 Terminal



The optional CRT-2 terminal connects to the control panel via the EIA-485 serial interface TB2. The CRT-2—can control and view events, points and history reports, control the system (Acknowledge, Alarm Silence, and System Reset). With a CRT-2 installed, you can also change important system operating parameters, such as enable/disable of addressable points, change alarm and pre-alarm sensitivities, clear verification counters, clear history, and set the pre-alarm action level. A CRT-2 displays 26 lines by 80 columns and can be located up to 50 feet from the control panel.

Notification Circuit and Control Modules

Overview

The control panel supports the following notification and control modules:

- Indicating Circuit Module (ICM-4)
- Indicating Circuit Expander (ICE-4)
- Control Relay Module (CRM-4)
- Control Relay Expander (CRE-4)
- Auxiliary Relay Module (ARM-4)

Descriptions of Modules

Table 1-12 contains descriptions of the notification circuit and control modules that can be used with the control panel:



Auxiliary Bell Power Cable (PN 71091) Provided with ICM-4 and ICE-4 modules.



ARM Harness (PN 71092) For connecting the ARM-4 to the driving relay module.

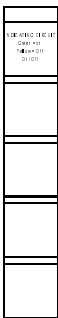

Slide-in Labels Provided with ICM-4 and CRM-4 modules.

Module	Function	Circuit Rating
ICM-4	Provides four Notification Appliance Circuits for Style Y or Style Z operation. Circuits are field-programmable to respond to a single initiating zone, a group of zones, or all initiating zones.	Maximum signaling current is 3 A of total current, limited by the power supply.
ICE-4	Expands the ICM-4 to a total of eight Notification Appliance Circuits (Style Y or Style Z).	Identical to the ICM-4.
CRM-4	Provides four standard dry Form-C relay contacts. Each relay is field-programmable to respond to a single initiating device circuit, a group of circuits, or all initiating device circuits. Each relay features manual On/Off control switches and can be disabled or enabled.	Contacts rated for 5 A at 120 VAC or 28 VDC (resistive).
CRE-4	Expands the capacity of the Control Relay Module (CRM-4) to eight Form-C alarm relays.	Identical to the CRM-4.
ARM-4	Provides four auxiliary Form-C relays that can be controlled by a CRM-4 or CRE-4 relay module.	Normally-open contacts rated for 20 A and the normally-closed contacts are rated for 10 A at 125 VAC and 30 VDC (resistive).

Table 1-12 Notification Circuit and Control Relay Modules

Voice Alarm Equipment

Overview

Voice Alarm equipment provides a manual or automatic supervised paging system for transmitting voice messages (information, instructions, directions) on a selective or all call basis. For more details, refer to Section 4, Voice Alarm System.

Audio Message Generator (AMG-1)

The heart of a voice evacuation system, the Audio Message Generator (AMG-1) provides a variety of tones, including a slow whoop, yelp, siren, hi/lo, or steady tone. A built-in microphone allows for paging through speaker circuits. Optionally, you can install up to four digitally-recorded voice messages into the AMG-1 from the following:

- two factory prerecorded VROM voice messages;
- two user-defined messages in the AMG-1;
- two user-defined messages (up to 24 seconds long) into an AMG-1 with optional VRAM-1 memory chips installed (one per VRAM).

You can create both user-defined messages through the AMG-1 built-in microphone, or download user-defined messages from a standard audio cassette recorder.

Audio Tone Generator (ATG-2)

The Audio Tone Generator (ATG-2) is similar to the AMG-1, but provides tones and microphone only (no message). It can provide two simultaneous tones for dual-channel applications.

Fire Fighters Telephone FFT-7/FFT-7S

The FFT-7 (Fire Fighters Telephone) provides the Voice Alarm System with fire fighter's telephone capability. With the FFT-7 or FFT-7S, up to seven telephones can hold a simultaneous conversation.

Voice Control Module (VCM-4)

The Voice Control Module provides the system with up to four Style Y or Style Z speaker circuits. Moving a jumper on the VCM-4 configures the module for driving FFT-7 (Fire Fighter Telephone) circuits. When configured for telephone circuits, the VCM-4 accepts its signal directly from an FFT-7/FFT-7S. Add an optional VCE-4 Voice Control Expander to the back of the VCM-4 to provide telephone or speaker circuits 5-8.

Dual Channel Module (DCM-4)

The DCM-4 Dual Channel Module provides the system with the capability to select one of two types of audio sources for switching to a specified speaker circuit. The DCM-4 provides up to four circuits.

Cabinet Hardware

Cabinet Overview

The control panel can be installed into one of two main cabinet configurations:

- An ADT-CAB-400AA for compact systems (ADT-CPU, MPS-400, and one option module). Door hinges are left-hand mounted and the door opens 180 degrees.
- An ADT-CAB-X3 cabinet for larger systems comes in four sizes (ADT-CAB-A3, ADT-CAB-B3, ADT-CAB-C3, or ADT-CAB-D3). An ADT-CAB-X3 consists of two basic components—a Surface-mounted Backbox (SBB-X3) and a door (ADT-DR-X3). Hinges are field-selectable for left- or right-hand mounting.
- Options for ADT-CAB-X3 cabinets include: 1) a Wire Channel (WC-2) option which provides a pair of wire trays for neater routing of wire between tiers (rows) in the cabinet (order one pair per cabinet tier); and 2) a trim ring option (TR-X3N) for semi-flush mounting (TR-A3N, TR-B3N, TR-C3N, TR-D3N).

A key-locked door includes a pin-type hinge, a window, two keys, and the necessary hardware to mount the door to the backbox. The backbox contains numerous knockouts to provide easy access to the cabinet and to simplify conduit installation.

CHS-4M Chassis/Dress Panel Assembly

The CHS-4M contains expansion modules that extend beyond the first row in the ADT-CAB-X3 cabinet. One CHS-4M is needed for each additional row of system modules. The CHS-4M includes the CHS-4 Chassis, the MP-1 Module Dress Panel, and the Expander Row Ribbon Cable.

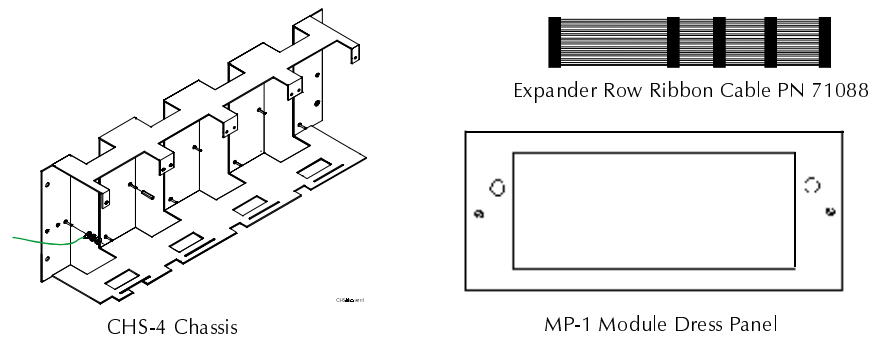

Figure 1-6 CHS-4 Chassis

CHS-4L Chassis

The low-profile CHS-4L chassis mounts into an ADT-CAB-X3 cabinet. Use the CHS-4L chassis to mount AA-30 audio amplifiers, Audio Message Generators, Fire Fighters Telephones, or Audio Visual Power Supplies.

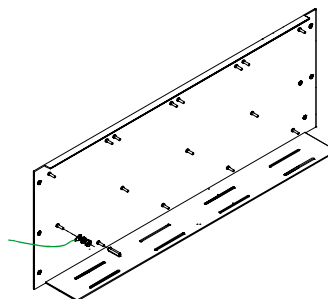

Figure 1-7 CHS-4L Chassis

ADT-CAB-X3 Series Cabinets

Overview

This section contains mounting information for ADT-CAB-X3 Series Cabinets. Each cabinet assembly includes a door and backbox. The following lists each ADT-CAB-X3 Series cabinet assembly:

- ADT-CAB-A3 – one mounting tier
- ADT-CAB-B3 – two mounting tiers
- ADT-CAB-C3 – three mounting tiers
- ADT-CAB-D3 – four mounting tiers

ADT-CAB-A3

An optional TR-A3N trim ring is available for use with an A-size cabinet (24-1/8"W by 22-5/16"H). Replacement parts: ADT-DR-A3 door; SBB-A3 backbox.

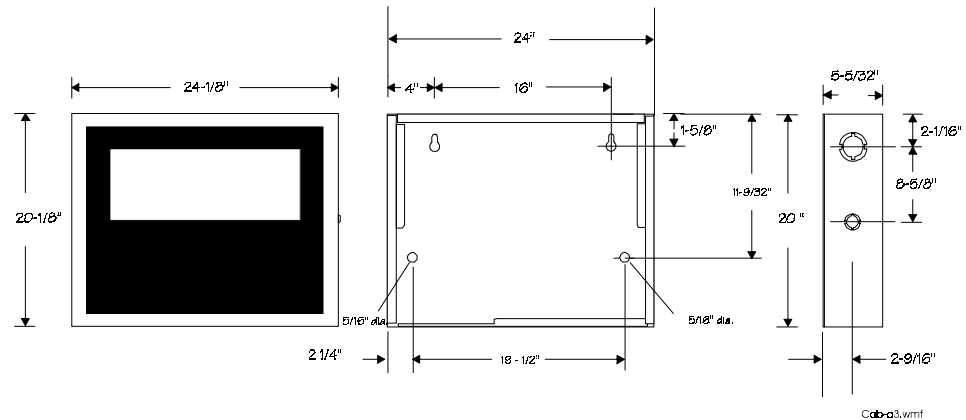

Figure 1-8 ADT-CAB-A3 Mounting Dimensions

ADT-CAB-B3

An optional TR-B3N trim ring is available for use with a B-size cabinet (24-1/8"W by 30-13/16"H). Replacement parts: ADT-DR-B3 door; SBB-B3 backbox.

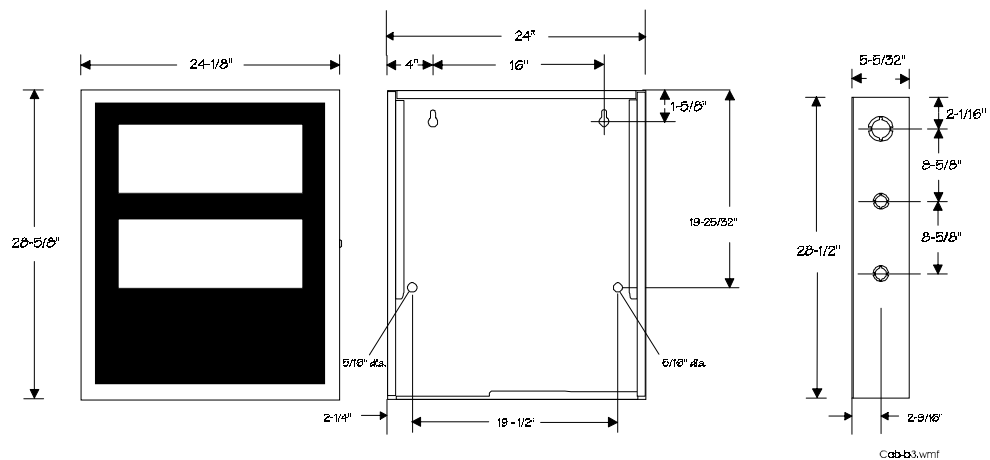
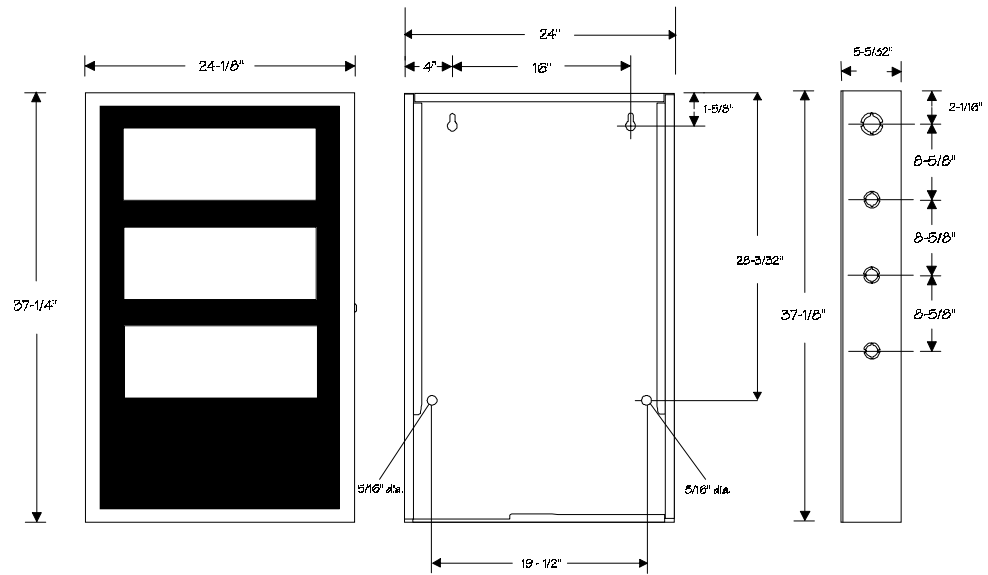

Figure 1-9 ADT-CAB-B3 Mounting Dimensions

ADT-CAB-C3

An optional TR-C3N trim ring is available for use with a C-size cabinet (24-1/8"W by 39-7/16"H). Replacement parts: ADT-DR-C3 door; SBB-C3 backbox.



Cab-c3.wmf

Figure 1-10 ADT-CAB-C3 Mounting Dimensions

ADT-CAB-D3

An optional TR-D3N trim ring is available for use with a D-size cabinet (24-1/8"W by 48-3/16"H). Replacement parts: ADT-DR-D3 door; SBB-D3 backbox.

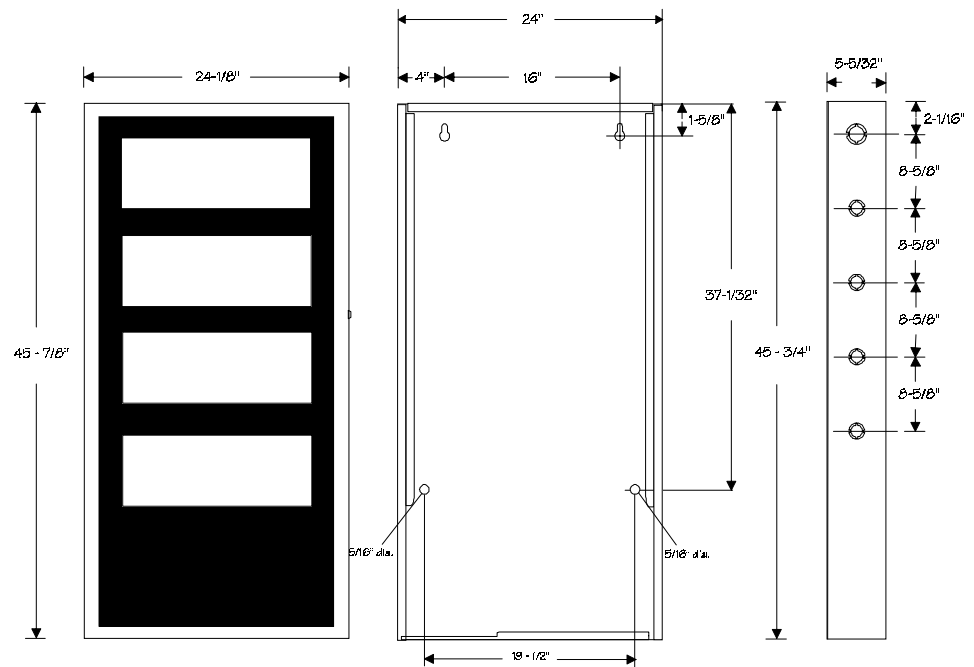

Cab-d3.wmf

Figure 1-11 ADT-CAB-D3 Mounting Dimensions

ADT-CAB-400AA Cabinets

ADT-CAB-400AA Overview

The ADT-CAB-400AA is a backbox and door that can contain a small Unimode 400 system. (A small system supports up to twelve NACs and consists of an ADT-CPU and one option module, such as an ICM-4/ICE-4.) Modules mount to rails in the ADT-CAB-400AA, eliminating the need for optional chassis assemblies. Mounting methods include surface-mounting or semi-flush mounting on a wall between 16-inch-on-center studs. Table 1-13 lists the components included in the ADT-CAB-400AA:

Component	Description
ADT-BE-400AA	ADT-BE-400AA A package that includes an ADT-CPU-400, an MPS-400RB, a transformer assembly, and a two-position ADT-CPU-400 ribbon cable.
ADT-CAB-400AA (includes ADT-DP-400AA)	A backbox (14.5" wide by 17" tall by 5" deep) and door (14.57" wide by 17.25" tall by 1.5" deep).
ADT-DP-400AA	An Inner Dress Panel for covering the backbox area surrounding the modules. The ADT-DP-400AA is required for Canadian installations.
BM-1	Blank module for covering an unused panel or module.
TR-500	Trim ring that provides for semi-flush mounting of the ADT-CAB-400AA cabinet

Table 1-13 ADT-CAB-400AA Components and Options

ADT-CAB-400AA Limitations

- Limited power supply capacity (one AVPS-24 expander).
- The backbox can hold 12 amp-hour batteries only.
- Maximum of one module in addition to the ADT-CPU.
- No voice evacuation capability.

ADT-CAB-400AA Dimensions

Figure 1-12 shows the ADT-CAB-400AA dimensions:

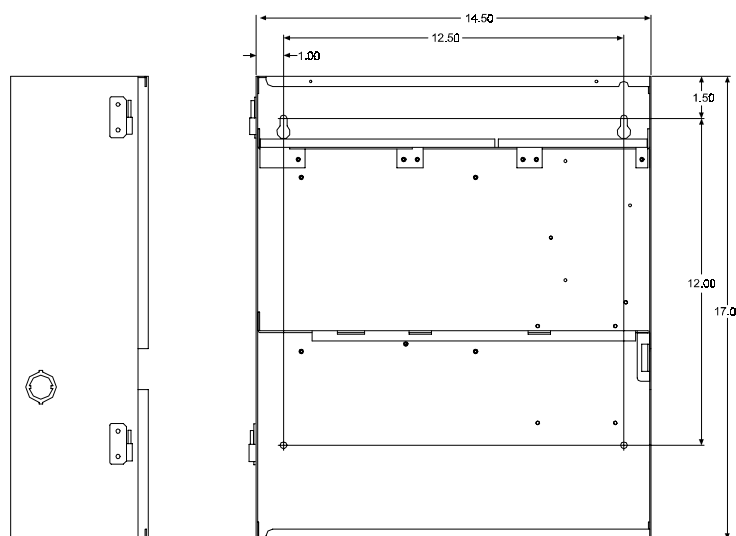
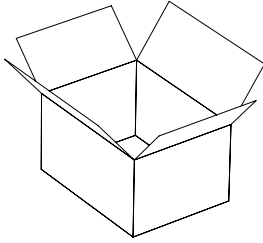

Figure 1-12 ADT-CAB-400AA Backbox and Door Assembly

Notes

2. Installation

Preparing for Installation



Unpacking the System. Unpack the system as follows:

Step	Action
1	Carefully unpack the system and inspect for shipping damage.
2	Select a location for the control panel in a clean, dry, vibration-free area with moderate temperature.

Before installing the fire alarm system, read the following:

- Install the system in a readily accessible area with sufficient room to easily install and maintain the control panel.
- Locate the top of the cabinet approximately 60 inches above the floor with the hinge mounting on the left.
- Count the number of conductors needed for all devices and find the appropriate knockouts.
- Review the installation precautions at the front of this manual.
- All wiring must comply with the National and/or Local codes for fire alarm systems.
- Do not draw wiring into the bottom 9 inches of the cabinet, except when using the BB-17 or BB-55 battery box. This prevents interference between the power supply and batteries.

Standards and Codes. In addition, installers should be familiar with the following standards:

- NEC Article 300 Wiring Methods.
- NEC Article 760 Fire Protective Signaling Systems.
- Applicable Local and State Building Codes.
- Requirements of the Local Authority Having Jurisdiction.

Installation Checklist



Caution: Make sure to install system components in the precise order in the checklist. Failure to do so, can damage the control panel and other system components

Table 2-1A contains an installation checklist for installing, wiring, and testing a Unimode 400 system:

Task	Refer to...
<input type="checkbox"/> Mount the CAB-X3 Cabinet Door (CAB-400AA has a pre-mounted door.)	"Installing a Cabinet Door" on page 2-4.
<input type="checkbox"/> Mount CHS-4 and CHS-4L chassis in CAB-X3 cabinets.	"Installing a Chassis (ADT-CAB-X3 Series Cabinets)" on page 2-6.
<input type="checkbox"/> Mount the SBB-X3 or CAB-400AA backbox to the wall.	"Mounting a Backbox (SBB-X3 and ADT-CAB-400AA)" on page 2-7.
<input type="checkbox"/> Mount the MPS-400 to the backbox.	"Mounting an MPS-400 Power Supply" on page 2-8.
<input type="checkbox"/> If using additional power supplies, mount to the AVPS-24 to the backbox or chassis.	"Mounting an Optional AVPS-24 Power Supply" on page 2-10.
<input type="checkbox"/> Mount optional Auxiliary Relay Modules (ARM-4).	"Installing an Auxiliary Relay Module (ARM-4)" on page 2-11
<input type="checkbox"/> Connect the power cables to the MPS-400 and any AVPS-24s, while the terminals are accessible.	"Field Wiring the MPS-400 Power Supply" on page 2-32.
Caution: Do not connect power at this time!	
<input type="checkbox"/> If installing panel modules (such as ICM-4, CRM-4, VCM-4), connect Expander Row Ribbon Cables (PN 71088) to the CPU.	"Installing Expander Row Ribbon Cables for Panel Modules" on page 2-15.
<input type="checkbox"/> Install the CPU module in the top left cabinet position.	"Installing the CPU" on page 2-18
<input type="checkbox"/> Connect the Power Ribbon and Power Harness between the CPU and the MPS-400/MPS-400RB.	"Connecting the CPU to the MPS-400" on page 2-19.
<input type="checkbox"/> Install panel module expander boards (ICE-4, CRE-4, VCE-4).	"Mounting Expander Modules (CRE-4, ICE-4, VCE-4)" on page 2-20
<input type="checkbox"/> Mount panel modules (ICM-4, CRM-4, VCM-4) to the chassis or backbox.	"Mounting Panel Modules (CRM-4, ICM-4, VCM-4) onto a Chassis" on page 2-21.
<input type="checkbox"/> Connect the Row Ribbon Cables to the panel modules.	"Installing Expander Row Ribbon Cables for Panel Modules" on page 2-15.
<input type="checkbox"/> Mount optional modules (such as 4XTM, ADT-UZC-256, UDACT).	"Installing a 4XTM Module (Remote Station Fire Alarm)" on page 2-22. "Installing an ADT-UZC-256 Module" on page 2-24.
<input type="checkbox"/> Install optional Voice Alarm System components.	Section 4.



Task	Refer to...
<input type="checkbox"/> Field-wire each module.	"Field-Wiring the Modules" on page 2-25.
<input type="checkbox"/> Install optional peripheral devices, such as a printer, personal computer, or CRT-2 terminal.	"Installing Remote Printers and CRTs" on page 2-35.
<input type="checkbox"/> Wire the Signaling Line Circuits.	"Wiring a Signaling Line Circuit (SLC)" on page 2-39.
<input type="checkbox"/> Connect AC power to the MPS-400 — but do not connect batteries (See Caution below).	"Field Wiring the MPS-400 Power Supply" on page 2-32 "AC and Battery Power Connections (MPS-400)" on page 2-33.
<input type="checkbox"/> Check AC power—but do not connect batteries.*	Table 2-2.
<input type="checkbox"/> Program the control panel.	Unimode 400 Programming Manual.
<input type="checkbox"/> Connect the batteries.	"AC and Battery Power Connections (MPS-400)" on page 2-33.
<input type="checkbox"/> Field test the system.	Section 3.

Table 2-1 Installation Checklist

Table 2-2 contains a checklist for checking the system with AC power applied:



Caution: While checking AC power, make sure batteries are not connected.

Component	Status
<input type="checkbox"/> The CPU	The green AC Power indicator on; the system Trouble indicator on because of no battery power.
<input type="checkbox"/> Each module	The yellow Trouble indicator may come on for approximately 10 seconds after applying AC power. (This only applies to an unconfigured system.)
<input type="checkbox"/> Each AVPS-24	The yellow Trouble indicator comes on because batteries are not connected.

Table 2-2 AC Power Checklist

Installing a Cabinet Door

Cabinet Door Mounting Guidelines

Cabinet doors mount in a left- or right-hand opening configuration, providing easier access for installation and service when two control panels are mounted in a confined area or side-by-side (as shown in Figure 2-1). The doors can be opened barn door style, creating an open work space. Before mounting any equipment in the backbox, make sure to attach the two hinges and the two alignment tabs. In this type of installation it is necessary to leave enough space between cabinets to insert a key into the locks on the door frames.

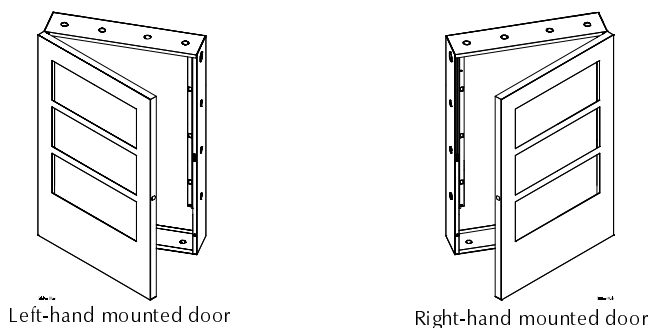

Figure 2-1 Cabinet Door Mounting Positions

How to Install a Cabinet Door (ADT-CAB-X3 only)

Note: Placing the door on the lower stud first provides a place for the door to rest while completing the assembly.

You can mount hinges on the left or right. The drawings and text refer to a left-mounted example. For right hand mounting, substitute right for left in the instructions. Follow the instructions in the installation table and refer to the drawings.

Step	Action
1	Insert the door hinges (A) into the top and bottom slots. (Figure 2-2 and Figure 2-3).
2	Attach the mounting nuts and secure the hinges to the backbox studs so the small hole on the outer tab faces out.
3	Thread the stud (B), from the bottom up, into the bottom hinge first. Place the grounding star washer and the lower corner of the door onto the stud.
4	Align the door on the backbox so the door sits directly under the top hinge. Thread the remaining stud (B) into the top hinge and through the hole in the top of the door. The door should now swing freely.

Table 2-3 Cabinet Door Installation Instructions

Installing a Top Hinge. Figure 2-2 shows how to mount a top hinge on a door:

Note: The installation is the same for the top and the bottom right corner of the backbox.

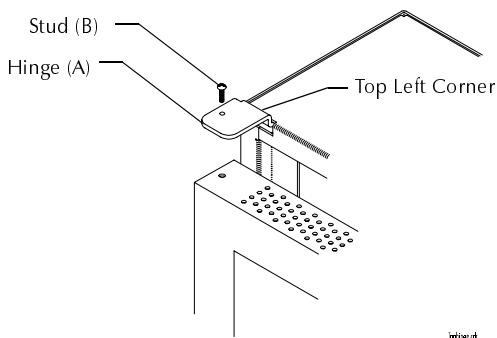

Figure 2-2 Installing a Top Hinge

Installing a Bottom Hinge. Figure 2-3 shows how to mount a bottom hinge on a door:

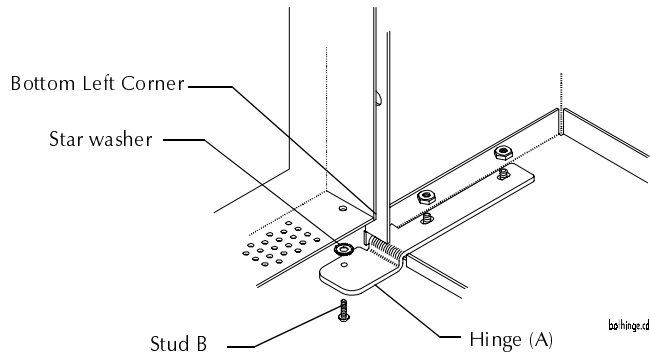

Figure 2-3 Installing a Bottom Hinge

Installing the Door Alignment Tabs

1. Install the door alignment tabs (C) in the unused slots on the top and bottom of the backbox. (In Figure 2-4, the door mounts on the left, leaving unused slots on the right). Secure the alignment tab (C) to the stud (b) with nut provided.
2. Punch out the knockout for the door lock on the side opposite the hinge.
3. Install the lock mechanism (Figure 2-5).

Note: Alignment tabs keep the door lined up with the backbox.

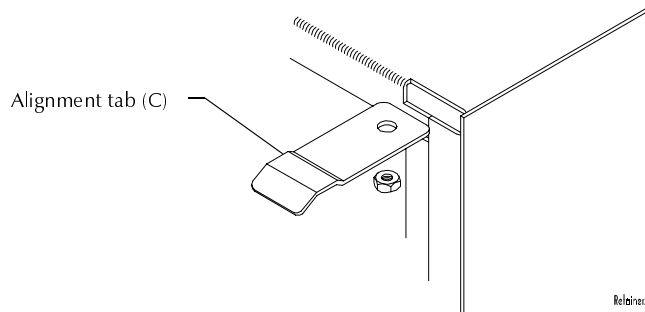
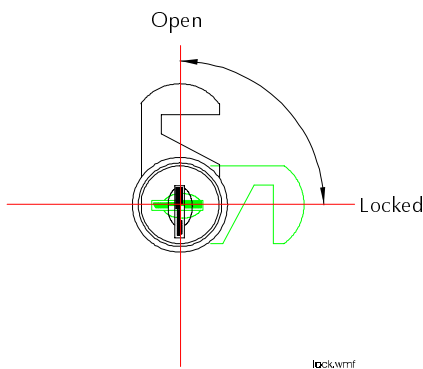

Figure 2-4 Installing the Door Alignment Tabs

Installing a Door Lock. Figure 2-5 shows how to install a door lock:



Door lock The door lock mechanism as viewed on a left-hand mounted door.

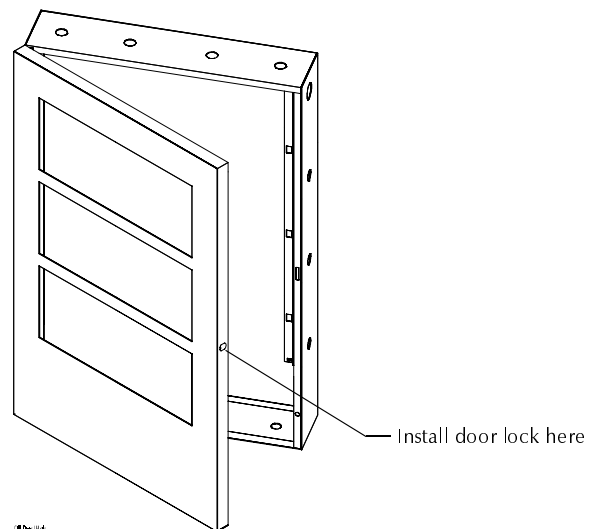

Figure 2-5 Installing the Door Lock

Installing a Chassis (ADT-CAB-X3 Series Cabinets)

Overview

This section contains instructions for installing a CHS-4 chassis (Figure 2-6) and a CHS-4L chassis (Figure 2-7) into an ADT-CAB-X3 cabinet.

Installing a CHS-4 Chassis

To install a CHS-4 chassis, follow these instructions:

1. Place the CHS-4 chassis over the screw mounts on the cabinet.
2. Connect a ground cable (PN 71033) to one of the screw mounts.
3. Secure the assembly with the two nuts provided.

Repeat this step for each CHS-4 chassis in the cabinet.

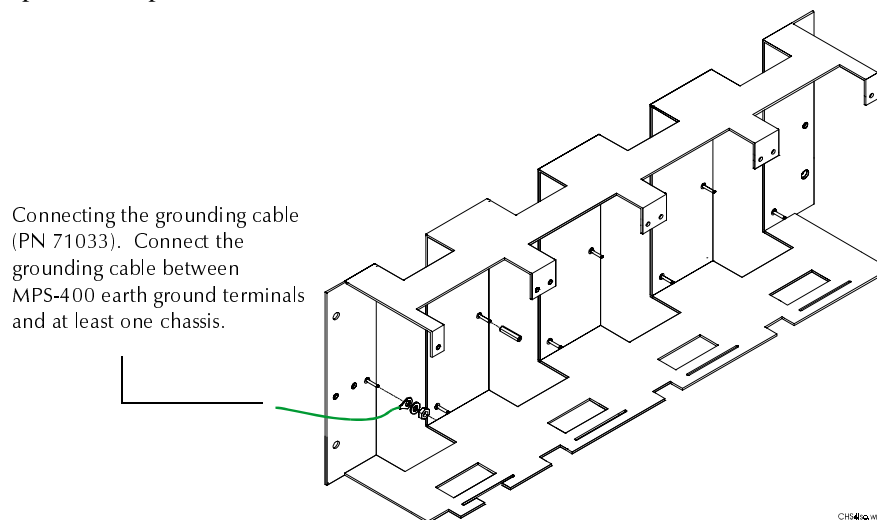

Figure 2-6 Installing a CHS-4 Chassis

Installing a CHS-4L Chassis

Use the CHS-4L chassis for mounting an AMG-1, FFT-7, or AA-30. To mount a CHS-4L, follow the steps for installing a CHS-4 chassis.

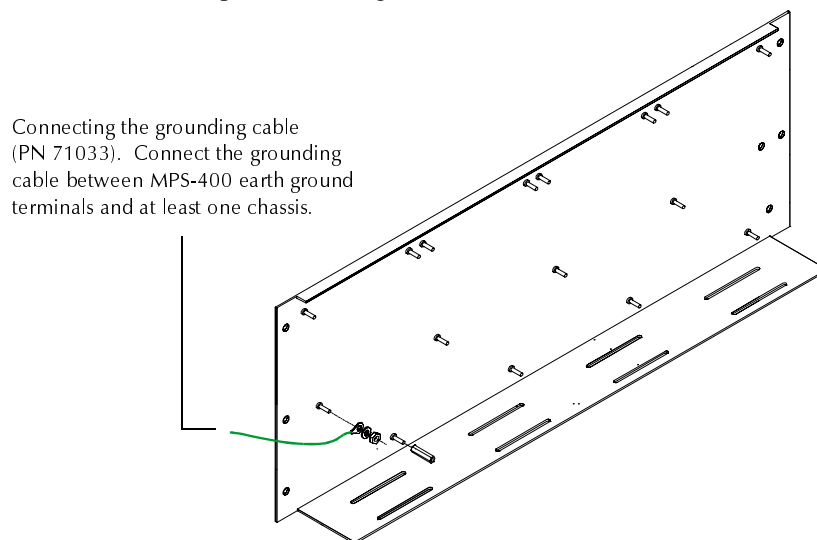

Figure 2-7 Installing a CHS-4L Chassis

Mounting a Backbox (SBB-X3 and ADT-CAB-400AA)

This section provides instructions for mounting an SBB-X3 or ADT-CAB-400AA backbox. Follow these guidelines when mounting a backbox:



Caution: Unless you are familiar with the placement of components within this backbox, only use the knockout locations provided for conduit entry.

- Mount a backbox on a surface in a clean, dry, vibration-free area. Install the cabinet by following the instructions in Table 2-4.
- Locate the backbox so that the top edge is 66 inches above the surface of the finished floor.
- Mount the backbox using the four mounting holes in the back surface of the backbox.

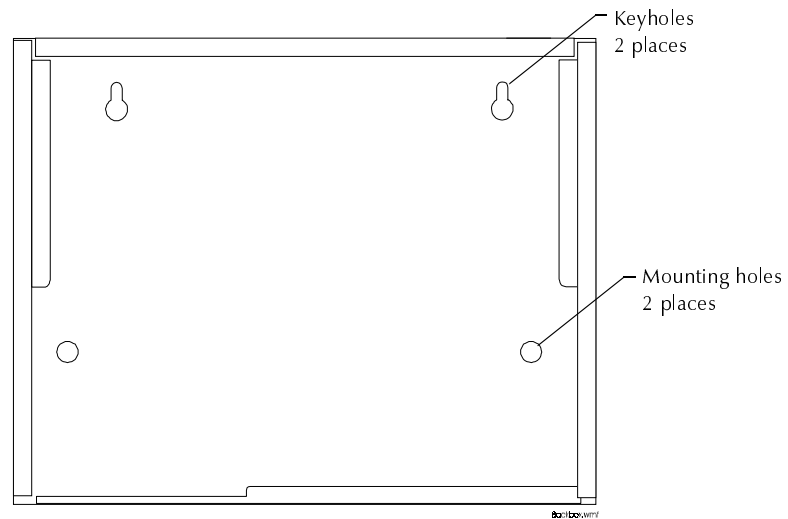
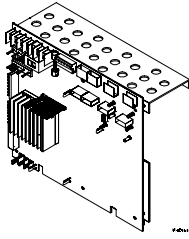

Figure 2-8 Mounting a Cabinet Backbox .

Step	Action
1	Mark and pre-drill holes for the top two keyhole mounting bolts.
2	Install two upper fasteners in the wall so the screw heads protrude approximately 1/2".
3	Using the keyholes, mount the backbox over the two screws.
4	Mark the two holes, remove the backbox and drill the mounting holes.
5	Mount the backbox, then install and tighten the remaining fasteners.

Table 2-4 Mounting a Cabinet Backbox

Mounting an MPS-400 Power Supply



Mounting an MPS-400 into an ADT-CAB-X3 Cabinet

This section contains instructions for mounting an MPS-400 into an ADT-CAB-X3 (Figure 2-9 and Figure 2-10) and for mounting an MPS-400 into an ADT-CAB-400AA (Figure 2-11).

The MPS-400 mounting assembly consists of the MPS-400 module attached to mounting chassis. To install the MPS-400 into ADT-CAB-A3, ADT-CAB-B3, ADT-CAB-C3, or ADT-CAB-D3 cabinets, follow these steps.

1. Place the MPS-400 assembly into the cabinet so the MPS-400 chassis bracket engages the support bracket on the cabinet as shown in Figure 2-9:

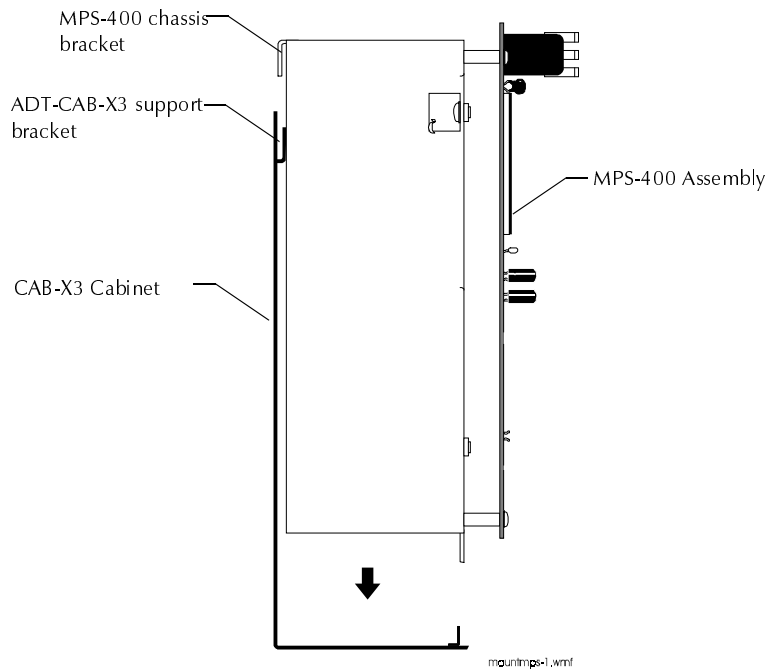

Figure 2-9 Placing an MPS-400 onto a Support Bracket

2. Secure the bottom of the MPS-400 to the bottom cabinet support with the mounting screws as shown in Figure 2-10:

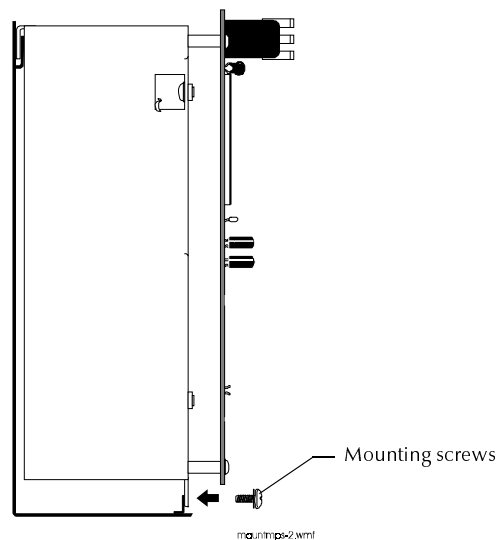

Figure 2-10 Mounting an MPS-400 into an ADT-CAB-X3

Mounting an MPS-400 into an ADT-CAB-400AA

Figure 2-11 shows how to install an MPS-400RB and two transformer assemblies into an ADT-CAB-400AA cabinet. To mount MPS-400RB components, follow these steps:

Step	Action
1	Mount the MPS-400RB PC board into the cabinet using the five mounting screws.
2	Mount the two 100VA transformer assemblies to the cabinet using the five mounting nuts and lockwashers.
3	Connect the transformer assembly wires to plugs P1 and P2 on the MPS-400RB PC board.

Figure 2-11 shows how to mount an MPS-400 to an ADT-CAB-400AA cabinet:

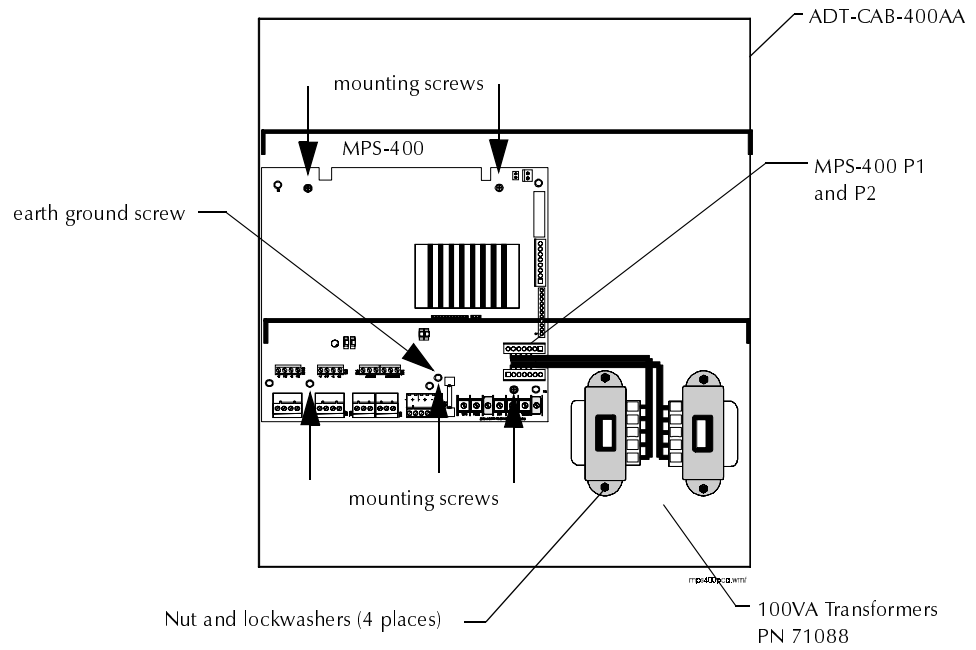

Figure 2-11 Mounting an MPS-400RB into an ADT-CAB-400AA

Mounting an Optional AVPS-24 Power Supply

Overview

You can mount an AVPS-24 into an ADT-CAB-X3 series cabinet (on a CHS-4 or CHS-4L chassis) or in the upper right corner of an ADT-CAB-400AA. A CRM-4, a ICM-4, a DCM-4, or a VCM-4 can mount above the AVPS-24 as long as you do not use an expander module (CRE-4, ICE-4, or VCE-4).

Installation

To mount an AVPS-24, refer to Figure 2-12 and follow these steps:

Step	Action
1	Place the AVPS-24 module onto the screw mounts on the CHS-4 or CHS-4L chassis as shown in Figure 2-12.
2	Install the two mounting nuts.
3	Tighten the mounting nuts until the module is secure. For wiring instructions, refer to "Field Wiring an Optional AVPS-24 Power Supply" on page 2-29.

Figure 2-12 shows how to mount an AVPS-24 onto a CHS-4L chassis:

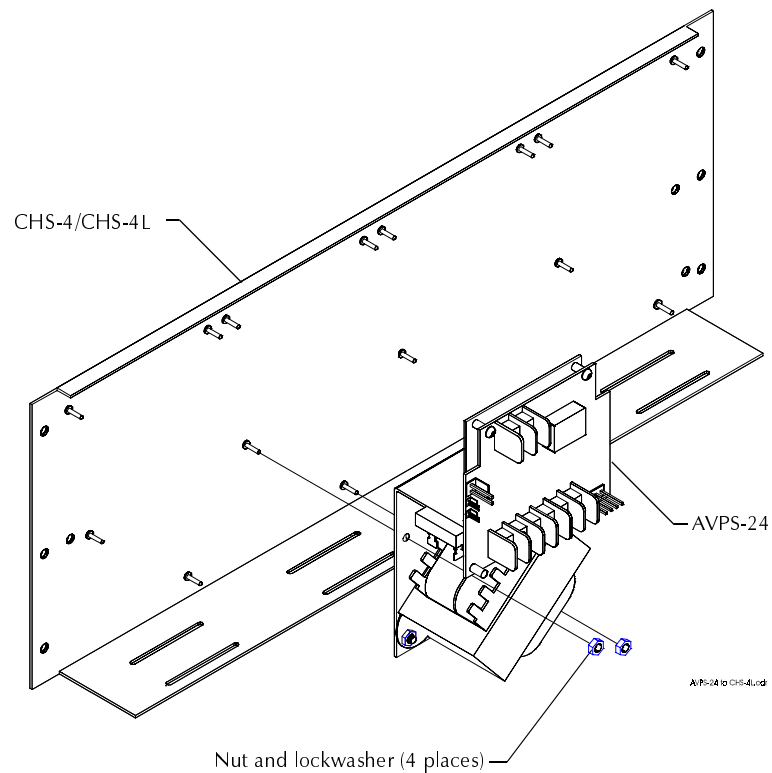

Figure 2-12 Mounting an AVPS-24 Power Supply

Installing an Auxiliary Relay Module (ARM-4)

Overview

The ARM-4 module can be driven by a CRM-4 or a CRE-4. Each ARM-4 can support one CRM-4 or one CRE-4. If using auxiliary relays for both modules, mount two ARM-4s in separate positions.

Note: For ease of installation and service, mount the ARM-4 module in a dedicated position on the chassis (if available) with no module or expander board above it. The ARM-4 can also mount in the upper right corner of the ADT-CAB-400AA.

Place the ARM-4 against the CHS-4 chassis in any one of eight positions relative to the CRM-4 or CRE-4 (Figure 2-13). You can also install the ARM-4 directly below the CRM-4 or CRE-4. Select a position on the CHS-4 chassis for the ARM-4:

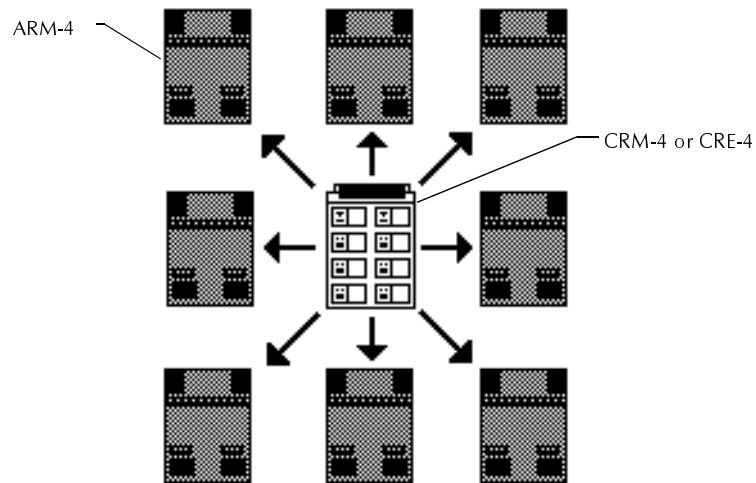

Figure 2-13 Mounting Positions for an ARM-4

Mounting the ARM-4 Module to a CHS-4 Chassis

1. Select a mounting position for the ARM-4 module on the CHS-4 chassis.
2. Secure the two loose standoffs to the screw mounts on the CHS-4 chassis at the selected location for the ARM-4. Make sure to install existing standoffs in the locations shown in Figure 2-14:

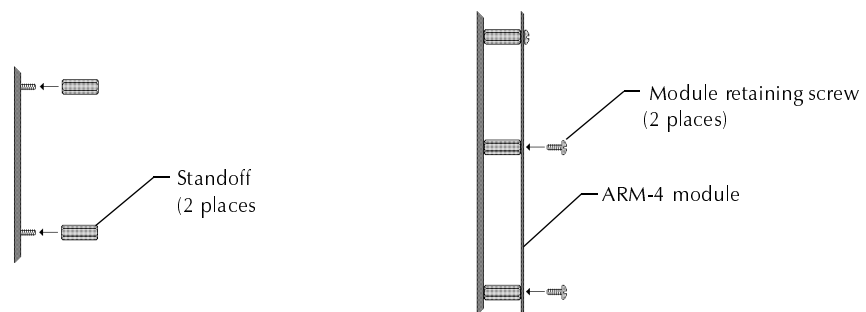

Figure 2-14 Mounting an ARM-4 to a CHS-4 Chassis

3. Position the ARM-4 module over the existing standoffs on the chassis; then, fasten the ARM-4 module to the chassis with the two module retaining screws as shown in Figure 2-14.

Wiring the ARM-4 Module

1. Connect one end of the ARM-4 cable to plug P1 on the ARM-4 (Figure 2-15).
2. Connect the other end of the ARM-4 cable to jumper JP5 on the CRM-4 or CRE-4 driving the ARM-4 module (Figure 2-15):

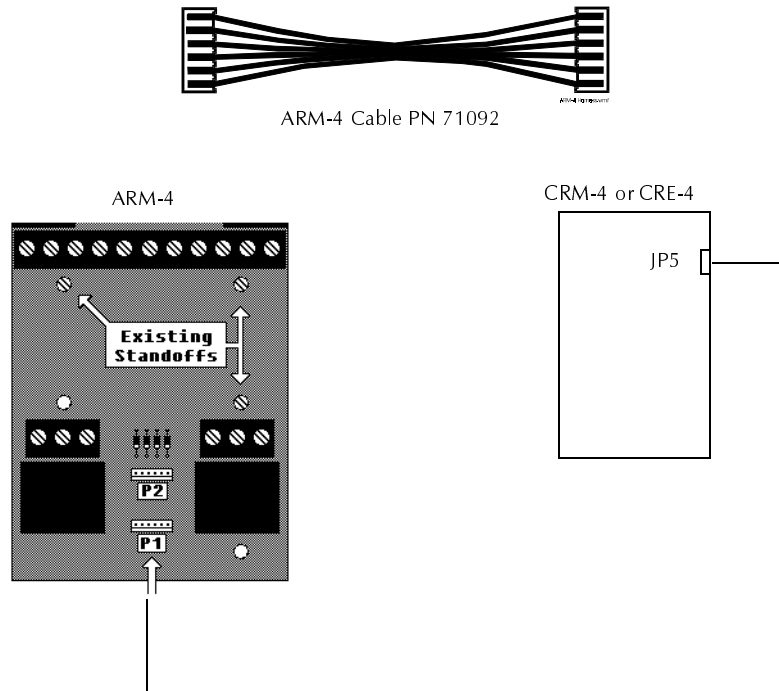

Figure 2-15 Connecting the ARM-4 to a CRM-4/CRE-4

Connecting the MPS-400 Power Cables

MPS-400 Electrical Connections

MPS-400 electrical connections include the following:

- Primary AC power source – 120 VAC, 50/60 Hz, 3.0 A or 240 VAC, 50/60 Hz, 1.5 A from line voltage source.
- Secondary power source – 24 VDC from batteries, installed in the control panel (or in an optional battery cabinet), provides backup power if the system loses primary power. Secondary (battery) power is required to support the system during loss of primary power.



Warning:

1. Remove all power sources to equipment while connecting electrical components. Leave the main power breaker off until installation of the entire system is complete.
2. Make sure to set the Voltage Selection Switch (S9) to the correct voltage.

Connecting the MPS-400 to AC Power (TB1)

Connect primary power to the MPS-400 as follows:

Step	Action
1	Set the Voltage Select Switch (S9 on the MPS-400) to match the incoming AC line voltage (120 VAC or 240 VAC).
2	Turn off the breaker at the main power distribution panel and remove the plastic insulating cover from TB1.
3	Connect the system primary power source.
4	Connect the service ground to TB1-3 (labeled EARTH).
5	Connect the primary Neutral line to TB1-2 and the primary Hot line to TB1-4 (marked HOT).
6	When finished making connections, reinstall the plastic insulating cover over TB1.

Table 2-5 Connecting AC (Primary) Power

Connecting the Batteries (MPS-400, TB1-6, TB1-7)

Install batteries in the control panel cabinet or in a separate battery cabinet which can be mounted up to 20 feet away from the control panel.



Warning: Do not connect the Battery Interconnect Cable (PN 71070) at this time. Make this connection after initial system primary power-up.

Connect the battery as follows:

Step	Action
1	Connect the battery positive terminal to TB1 terminal 6 (+).
2	Connect the battery negative terminal to TB1 terminal 7 (-).

Table 2-6 Connecting Batteries

Connecting Four-Wire Smoke Detector 24 VDC Power (MPS-400, TB2)

MPS-400 TB2 terminals TB2-5 (+) and TB2-6 (-) provide up to 1.25 A of current for four-wire smoke detectors. A system reset removes the 24 VDC power from MPS-400 TB2. 24 VDC low-noise four-wire smoke detector power is power-limited but must be supervised. To provide supervision, install an end-of-line listed power supervision relay. Connect the power supervision relay in series with an Initiating Device Circuit (IDC). The four-wire power circuit energizes the power supervision relay.

Notification Appliance Power (24 VDC)

TB2 terminals TB2-1 (+) and TB2-2 (-) provide up to 1.25 A of nonresettable low-noise current for powering notification appliances. TB2 terminals TB2-3 (+) and TB2-4 (-) also provide 1.25 A of nonresettable low-noise current. TB2 terminals TB2-5 (+) and TB2-6 (-) provide 1.25 A of resettable power.



Caution: During system reset, power remains at terminals TB2-1, TB2-2, TB2-3, and TB2-4.
 Note: On the MPS-400 Bell Power Harness, the fork lugs must be cut off and wires stripped for connection to the MPS-400.

Annunciator Power (24 VDC)

Power ACS annunciators from the four-wire smoke detector outputs, or from one of the NAC power outputs. All outputs provide the filtered, low-noise, power-limited source required by the annunciators. The power run to the annunciators is supervised by the annunciator (for a Loss of Communications error). Annunciator wiring must run separate from NAC wiring. You can use any of the NAC outputs, but do not connect an NAC to the output selected for powering the annunciators.

System Harness Connections

Make system connections as follows as shown in Table 2-7:

For...	Connect...
Internal system power	The power harness (75396 for ADT-CAB-400AA/75395 for ADT-CAB-X3 series) from J6 on the MPS to J6 on the CPU.
AMG-1 power	A power harness from J1 on the MPS to P1 on the AMG-1. You can feed this same power to other boards or modules that require internal power.
Signaling between the CPU and the MPS	A power ribbon (75398 for ADT-CAB-400AA/75394 for ADT-CAB-X3 series) to J2 on the MPS.

Table 2-7 System Harness Connections

System Power Connections

Figure 2-16 contains a block diagram that shows system power connections between the MPS-400 and Unimode 400 system components:

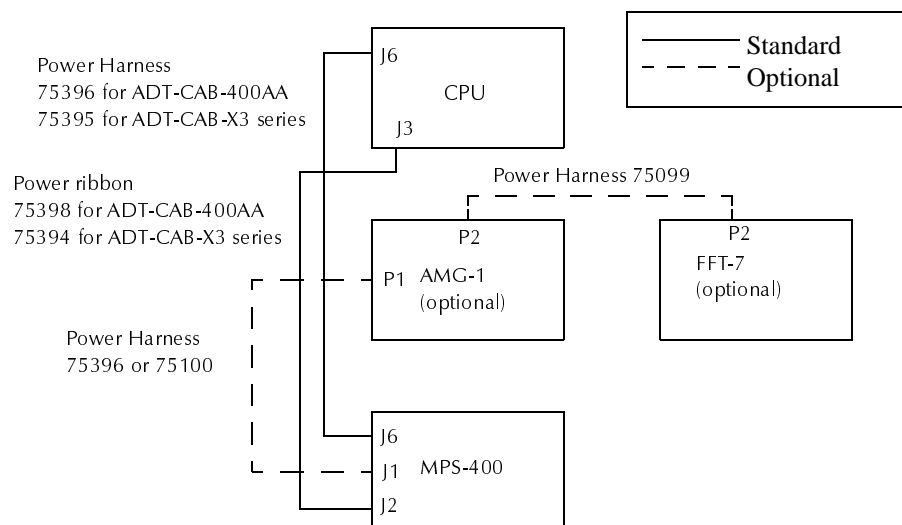

Figure 2-16 System Power Harness Connections

Installing Expander Row Ribbon Cables for Panel Modules

Expander Row Ribbon Cables (PN 71088) connect panel modules (ICM-4, CRM-4, VCM-4) to the CPU. Figure 2-17, Figure 2-18, and Figure 2-19 show typical wiring connections using Row Ribbon Cables.

Installing Row Ribbon Cables for ADT-CAB-B3 – ADT-CAB-D3 Cabinets

Figure 2-17 shows typical wiring connections using Expander Row Ribbon Cables to connect the CPU to two rows of panel modules. In Figure 2-17, P indicates a panel module. For example, P1.1 indicates panel module 1, circuit number 1.

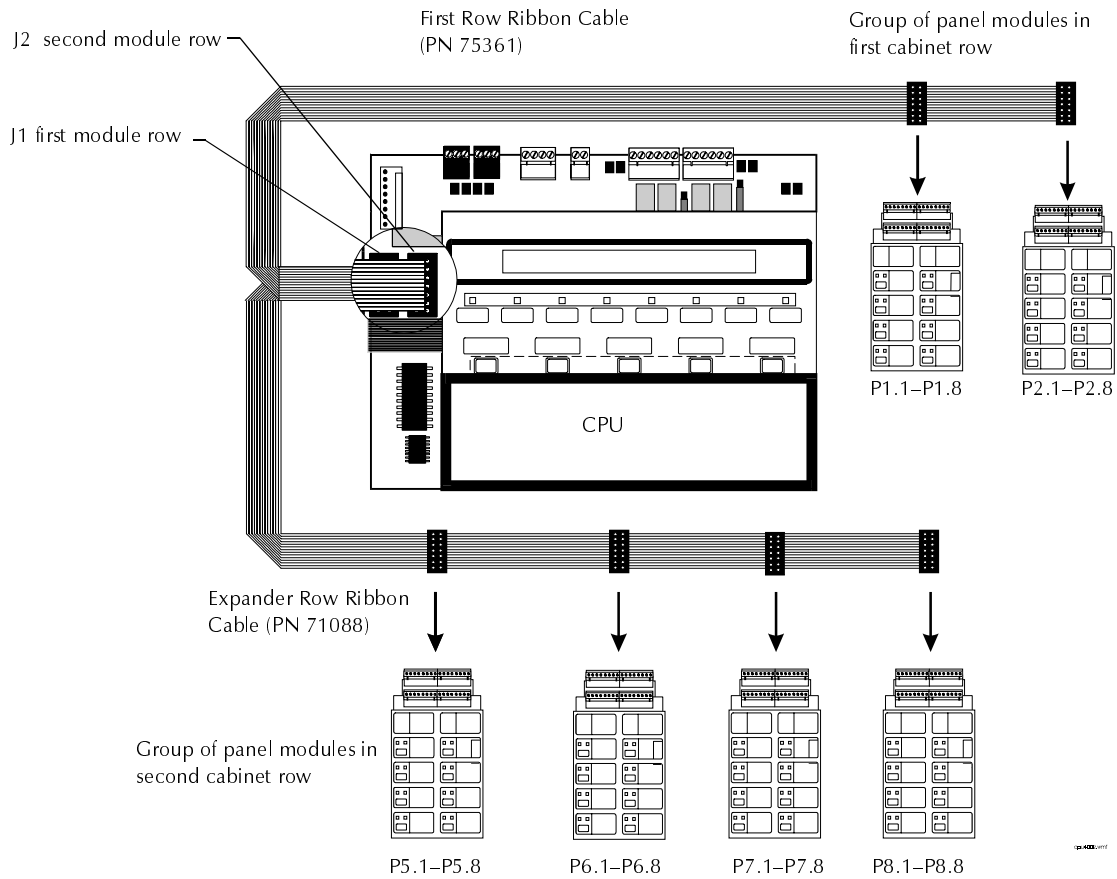

Figure 2-17 Installing Expander Row Ribbon Cables (ADT-CAB-B3 – ADT-CAB-D3)

Installing Row Ribbon Cables for ADT-CAB-C3 and ADT-CAB-D3 Cabinets

Figure 2-18 shows typical wiring connections to connect the CPU to two rows of panel modules.

Note: In the figure, "P" indicates a panel module. For example, P1.1 indicates panel module 1, circuit number 1.

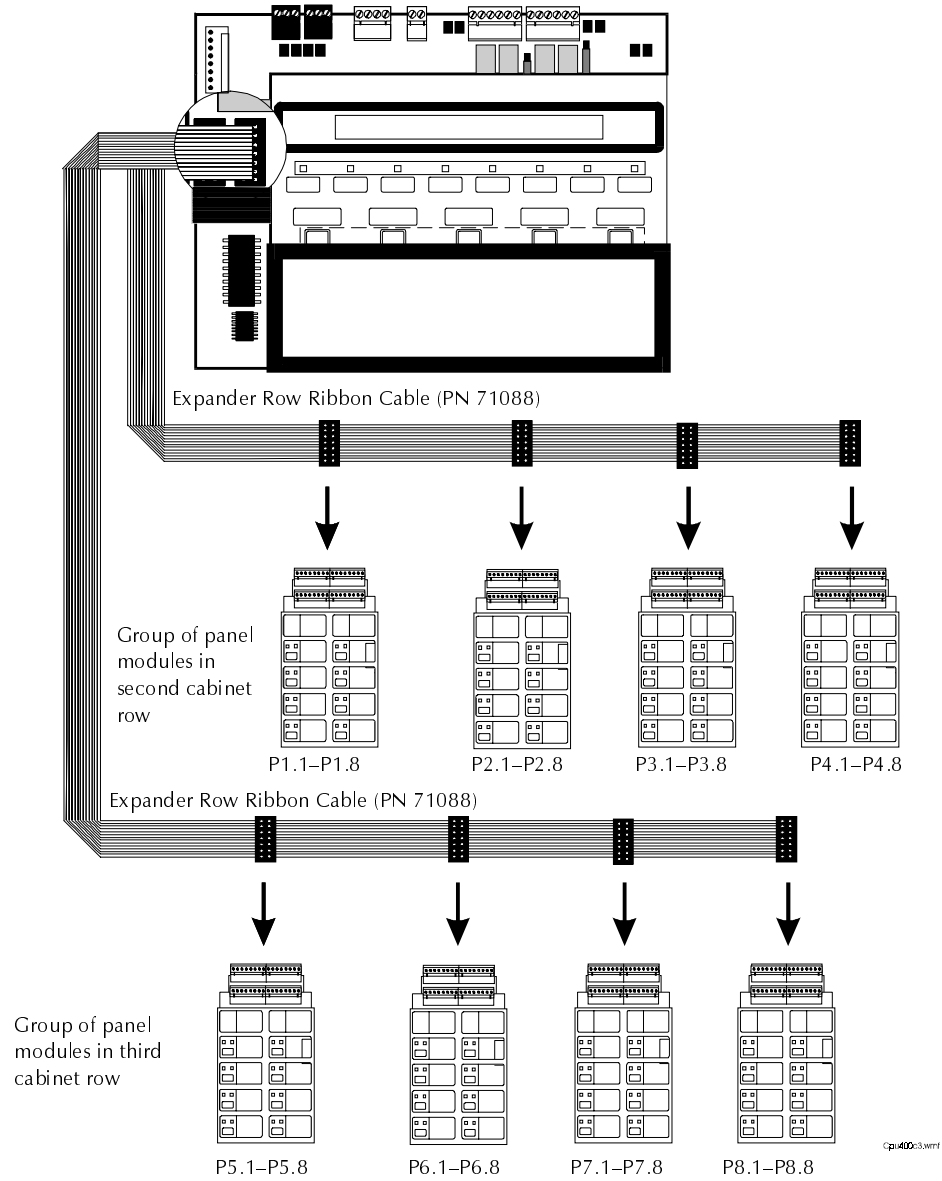

Figure 2-18 Installing Expander Row Ribbon Cables (ADT-CAB-C3 and ADT-CAB-D3)

Installing Row Ribbon Cables for an ADT-CAB-400AA Cabinet

Figure 2-19 shows typical wiring of the CPU to a row of panel modules:

Note: In the figure, "P" indicates a panel module. For example, P1.1 indicates panel module 1, circuit number 1.

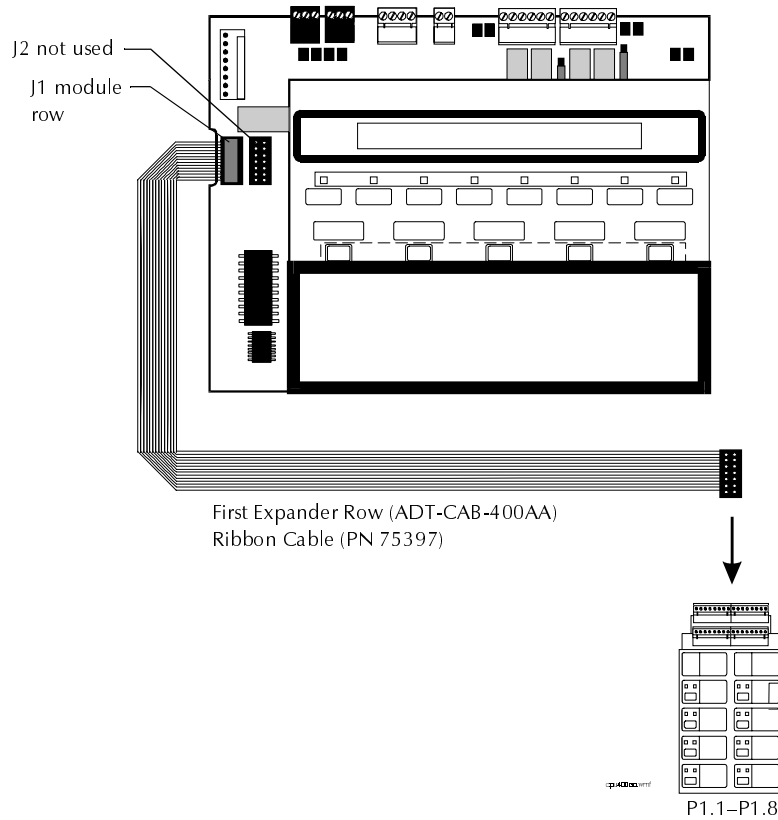

Figure 2-19 Installing an Expander Row Ribbon Cable (ADT-CAB-400AA)

Installing the CPU

Installing the CPU into a Chassis

To install the CPU into a chassis, follow these steps.

1. Insert the two tabs of the CPU module into the two left-most chassis slots, angling the front end of the module into position as in Figure 2-20:

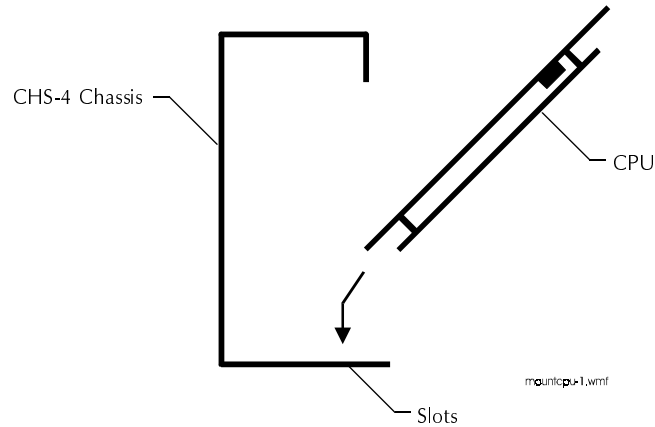

Figure 2-20 Inserting a CPU into a Chassis

2. Push the back end of the module down into the cabinet and pull down until the upper board engages the slots on the chassis as shown in Figure 2-21:

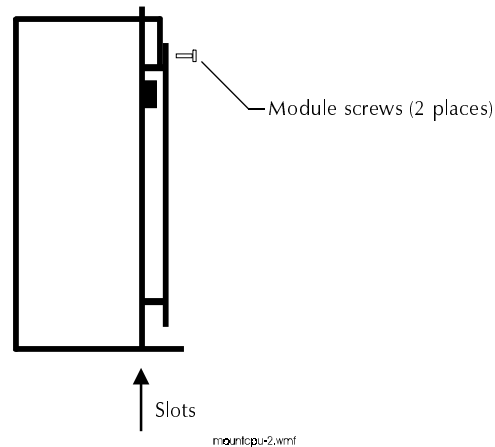

Figure 2-21 Securing a CPU to a Chassis

3. Align the module screws with the thread-holes on the chassis and secure in place.

Connecting the CPU to the MPS-400

Connect the CPU to the MPS-400 using the Power Harness and the Power Ribbon Cable as shown in Figure 2-22:

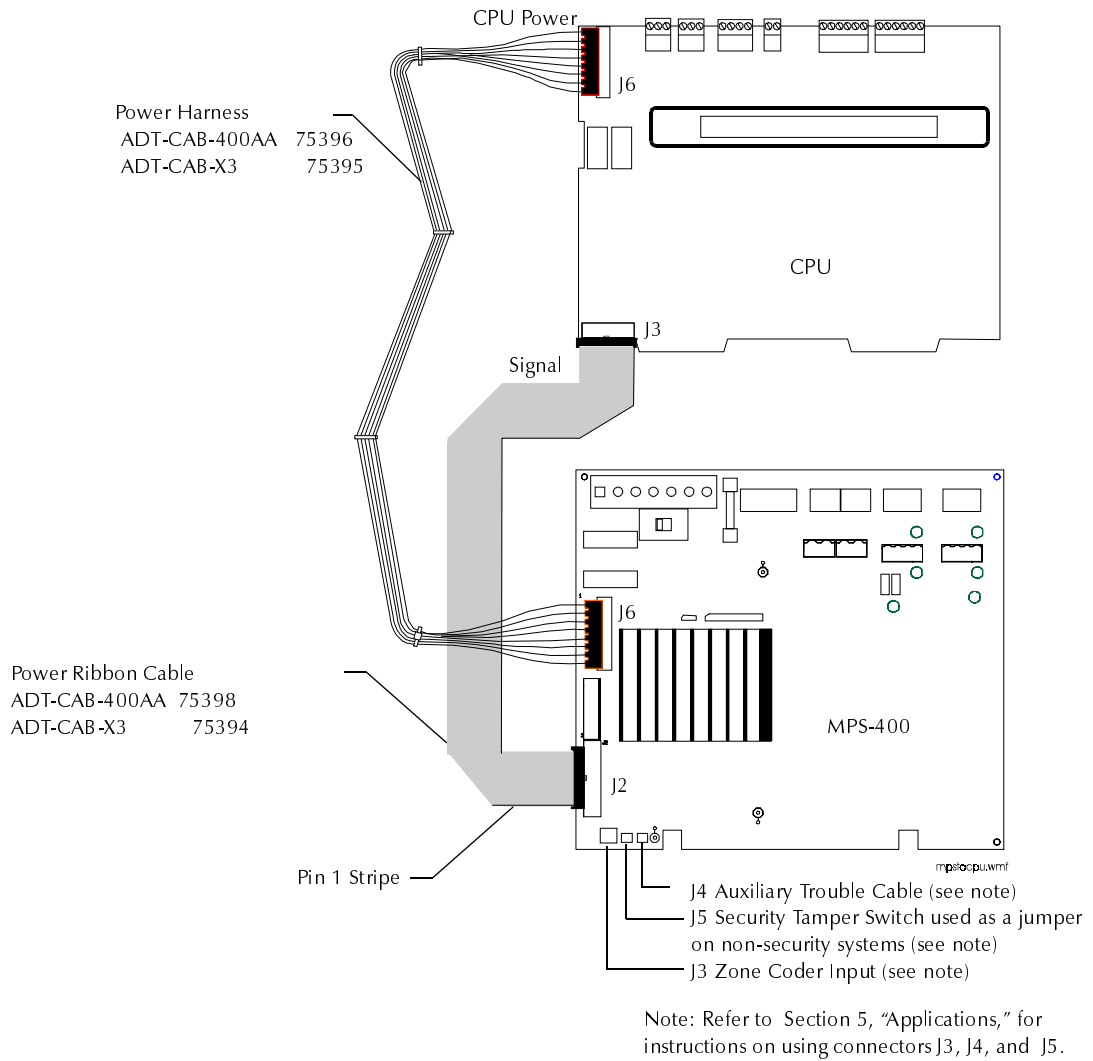

Figure 2-22 Connecting the CPU to the MPS-400

Mounting Expander Modules (CRE-4, ICE-4, VCE-4)

Table 2-8 contains illustrations and instructions for mounting an expander module to a CRM-4, ICM-4, or VCM-4 module:

Step	Action
1	<p>Remove one module support screw and set it aside for later use.</p> 
2	<p>Replace the module support screw with one module standoff.</p> 
3	<p>Repeat Steps 1 and 2 for the three remaining module support screws.</p>
4	<p>Insert pins on the Expander Module into connector on the module. Make sure the pins are in line; then, press the two boards together until the boards snap into place.</p> 
5	<p>Install the four module support screws (removed earlier) through the back of the Expander Module and into the standoffs.</p> 

Table 2-8 Installing an Expander Module

Mounting Panel Modules (CRM-4, ICM-4, VCM-4) onto a Chassis

To install a module onto a CHS-4 chassis, follow these steps.

1. Angle the module into the chassis so that the upper board edge slips into the chassis slots as shown in Figure 2-23:

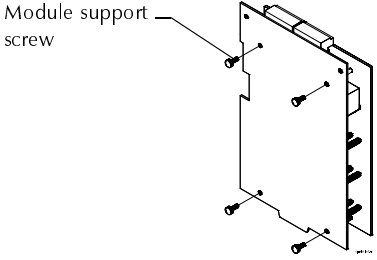
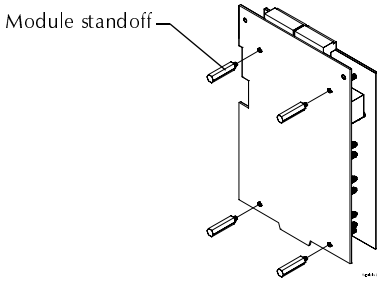
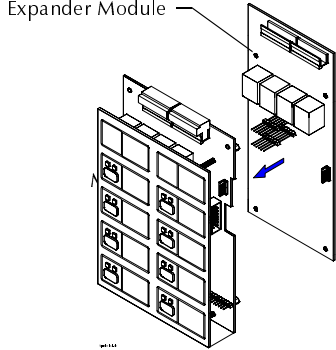
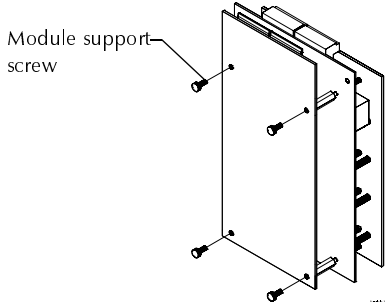
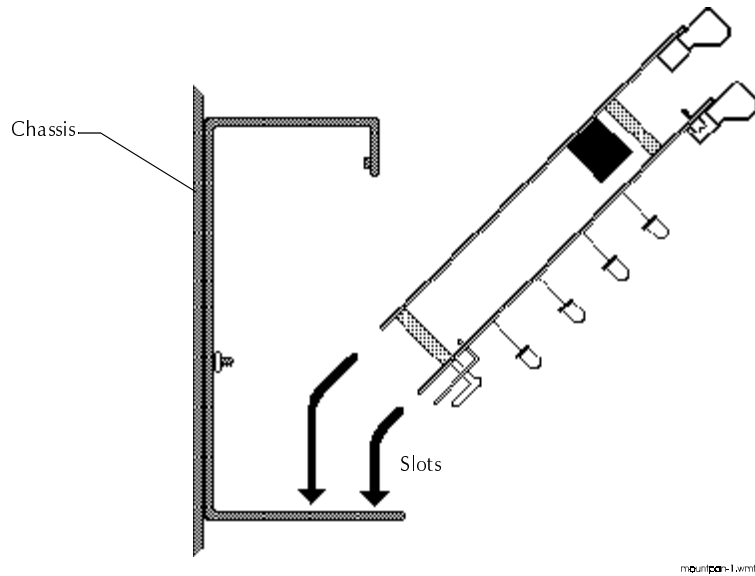

Figure 2-23 Inserting a Module to a CHS-4 Chassis

2. Push the upper end of the module into the slots in the chassis. Secure the module to the chassis with the two module screws (Figure 2-24).

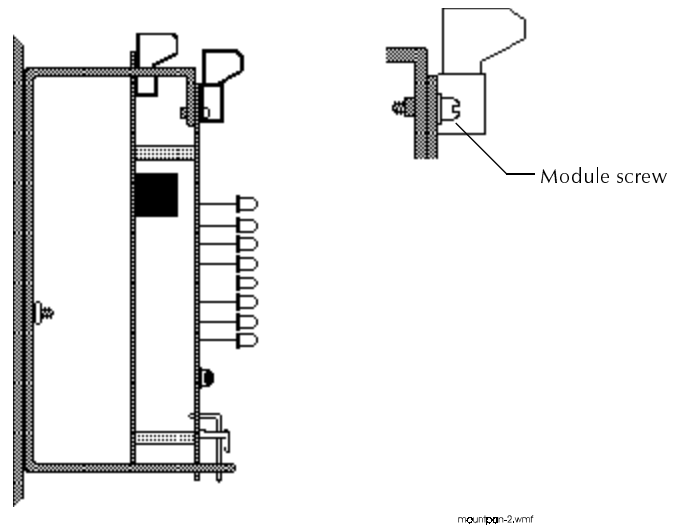

Figure 2-24 Securing a Module to a CHS-4 Chassis

Installing a 4XTM Module (Remote Station Fire Alarm)

Mounting the Module

Install the 4XTM module by following these steps:

Step	Action
1	Install the standoffs (provided) into the holes next to TB1 on the MPS-400 board.
2	Carefully align the pins on the MPS-400 PC board with the connector on the 4XTM board.
3	Press firmly on the 4XTM board until the board locks in place on the standoffs.
4	Screw the 4XTM board to the standoffs.

Table 2-9 Mounting a 4XTM Module

Figure 2-25 shows where to mount a 4XTM module on the MPS-400 board:

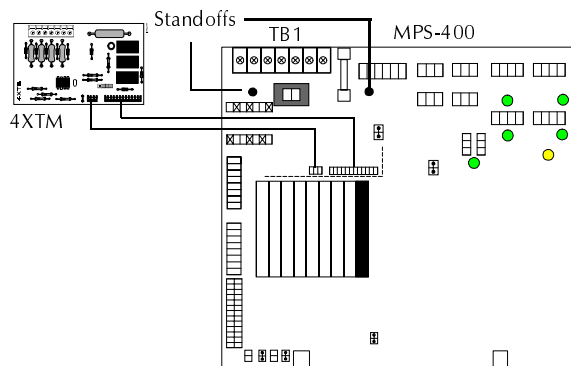

Figure 2-25 Mounting a 4XTM Module

4XTM Electrical Requirements

Electrical requirements for local energy municipal Box service (NFPA 72 Auxiliary Protective Fire Alarm System) are:

Supervisory current	5.0 mA
Trip current	0.35 A (subtracted from NAC power)
Coil voltage	3.65 VDC
Coil resistance	14.6 ohms

Electrical requirements for remote station service (NFPA 72 Remote Station Protective Fire Alarm System) are:

Wire resistance (panel and trip coil)	Maximum of 3.0 ohms
Maximum load for each circuit	10 mA
Reverse polarity output voltage	24 VDC (nominal) 28 VDC (max)

Note: The Local Energy Municipal Box Circuit is nonpower-limited. Maintain at least a 0.25 inch spacing between the Municipal Box Circuit wiring and all power-limited circuit wiring.

Connecting the 4XTM Module

Push the Disconnect Switch (Figure 2-26) down to prevent unwanted activation of the Municipal Box during testing of the control panel.

- The 4XTM Disconnect LED lights while the Municipal Box is disconnected; and
- The CPU System Trouble LED lights to indicate disconnected and/or open circuit conditions on the Municipal Box.

During trouble conditions, you can transmit a trouble indication through an open circuit signal on the Alarm Reverse-Polarity output. Do this by cutting the TBL jumper (Figure 2-26). Figure 2-26 shows connections to the 4XTM with polarities shown in the activated position:

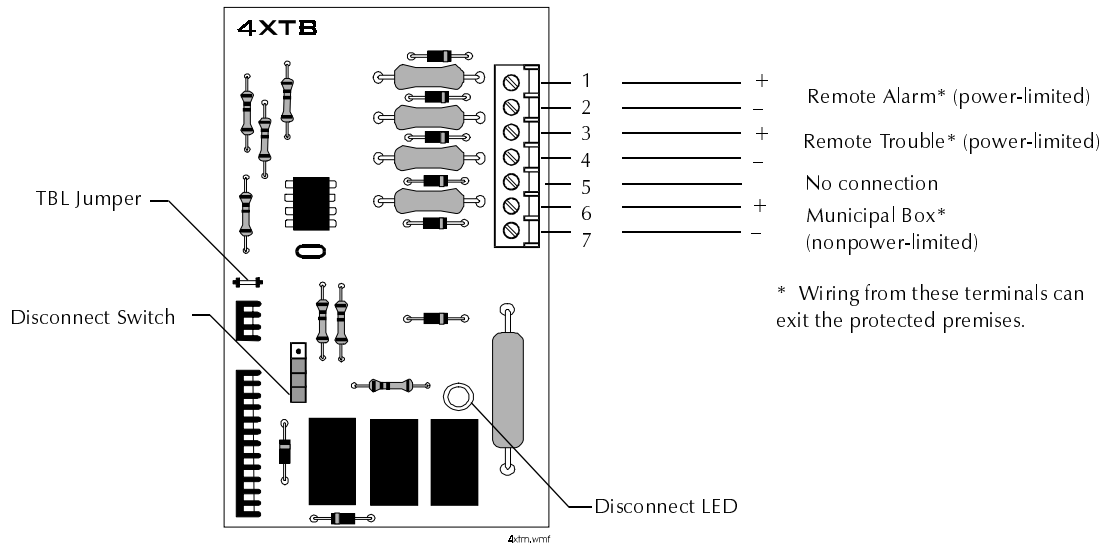

Figure 2-26 4XTM Transmitter Module (Polarities shown in activated positions)

Installing an ADT-UZC-256 Module

Overview

You can mount the ADT-UZC-256 into an ADT-CAB-X3 or an ADT-CAB-400AA. This section shows how to install the ADT-UZC-256 both ways. For information on configuring the ADT-UZC-256 module, refer to Section 5, “Applications.”

ADT-CAB-X3 Installation

The ADT-UZC-256 mounts beneath the third and fourth modules on the CHS-4 chassis, to the right of the CPU. Install the module as follows:

1. Thread the supplied three hex standoffs to the mounting studs on the CHS-4 chassis (Figure 2-27).

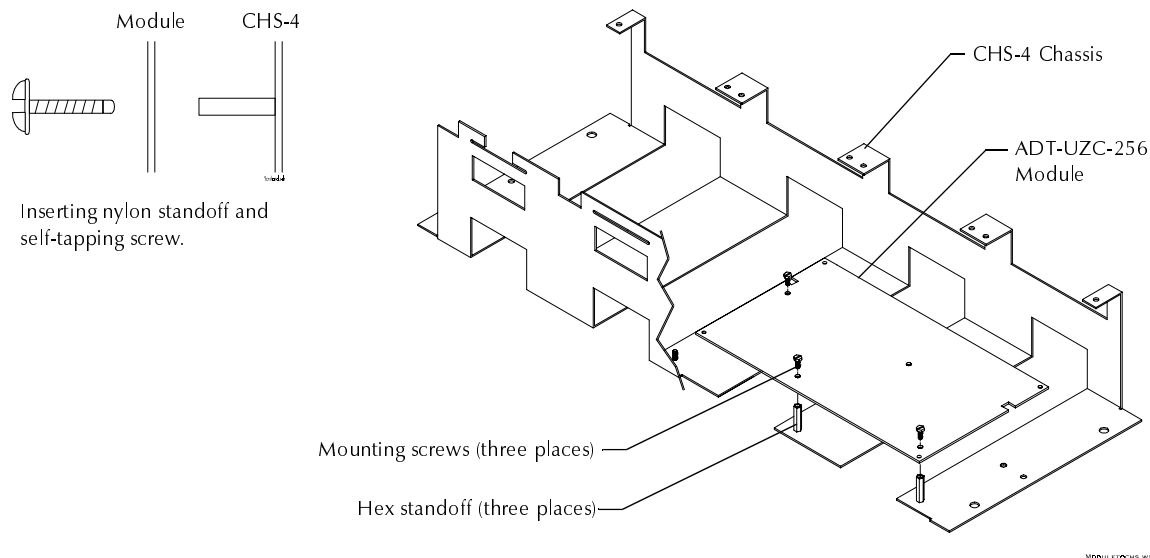

Figure 2-27 Mounting an ADT-UZC-256 to a CHS-4

2. Place the module onto the CHS-4 as shown in Figure 2-27; then, insert and tighten the mounting screws.

ADT-CAB-400AA Installation

You can also mount the module to the upper right corner of the ADT-CAB-400AA Series cabinet as follows:

1. Place the module into the ADT-CAB-400AA as shown in Figure 2-28.

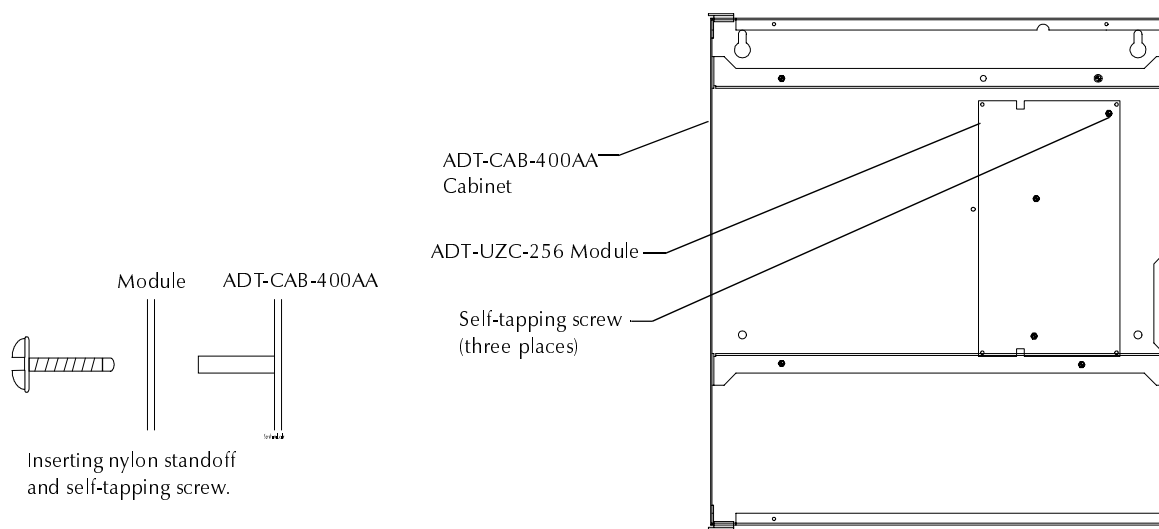

Figure 2-28 Mounting the ADT-UZC-256 into an ADT-CAB-400AA Cabinet

2. Attach the module to the ADT-CAB-400AA with the self-tapping screws.

Field-Wiring the Modules

This section contains instructions for the following:

- Notification Appliance Circuit (NAC) Wiring
- Field-wiring an ICM-4 and an ICE-4 (NFPA Style Y and Z)
- Field-wiring a CRM-4 and the CRE-4
- Field-wiring the MPS-400 Power Supply
- Field-wiring an ARM-4

Notification Appliance Circuit (NAC) Wiring

Note: Total in these figures assumes that no notification appliance power is drawn for any other purpose.

The total current available from any group of Notification Appliance Circuits (NACs) cannot exceed the following:

- 3.0 A when powered from the AVPS-24; or
- 1.25 A when powered from an MPS-400 output.

Figure 2-29 shows the bottom wire connections of the ICM-4 and the ICE-4 modules:

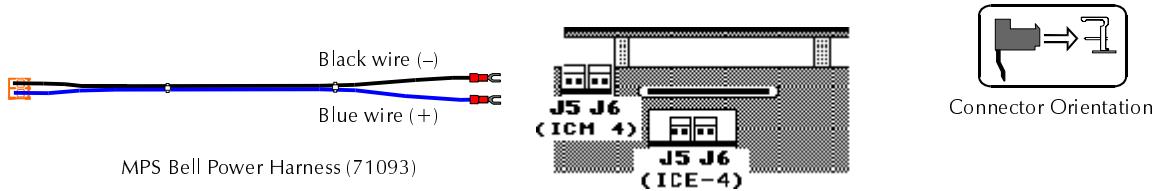

Figure 2-29 ICM-4/ICE-4 Connector

MPS-400/ICM-4 NAC Configurations

Typical Power Supply/ Notification Appliance Circuit Configurations

Figure 2-30, Figure 2-31, Figure 2-32, Figure 2-33, and Figure 2-34 show typical power supply (MPS-400 and AVPS-24) to NAC configurations.

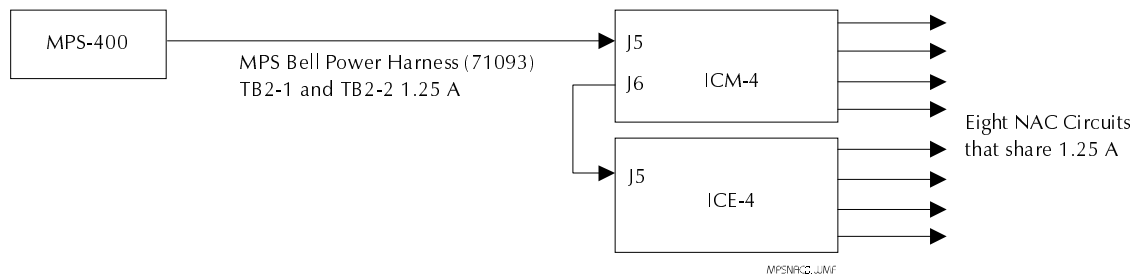

Figure 2-30 MPS-400 NAC Configuration (Eight NACs)

Figure 2-31 shows a block diagram that uses four NACs:

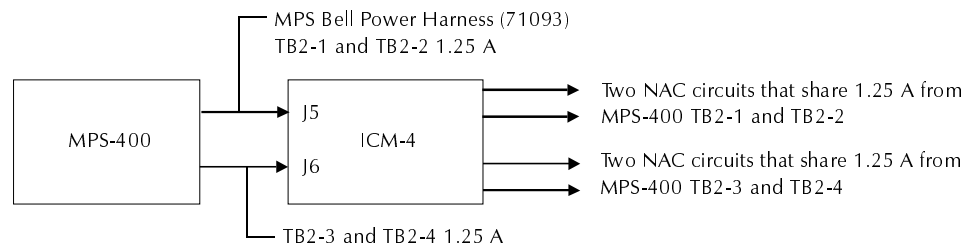

Figure 2-31 MPS-400 NAC Configuration (Four Circuits)

Figure 2-32 shows a block diagram that uses four NACs:

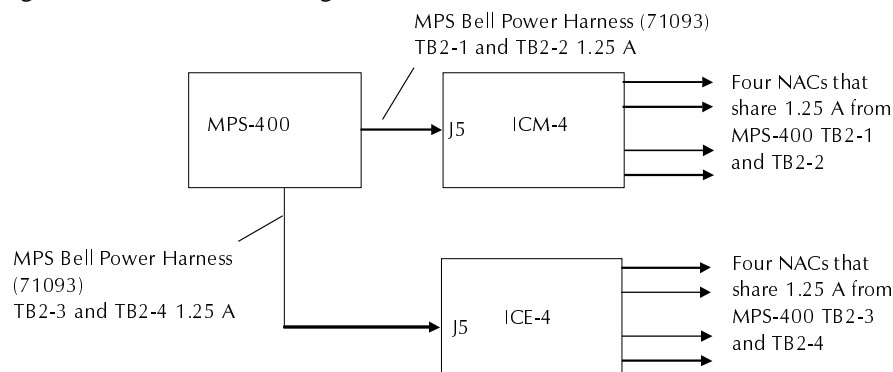

Figure 2-32 MPS-400 NAC Configuration (Four Circuits)

AVPS-24/ICM-4 NAC Configurations

Figure 2-33 shows typical NAC configurations using AVPS-24 power supplies:

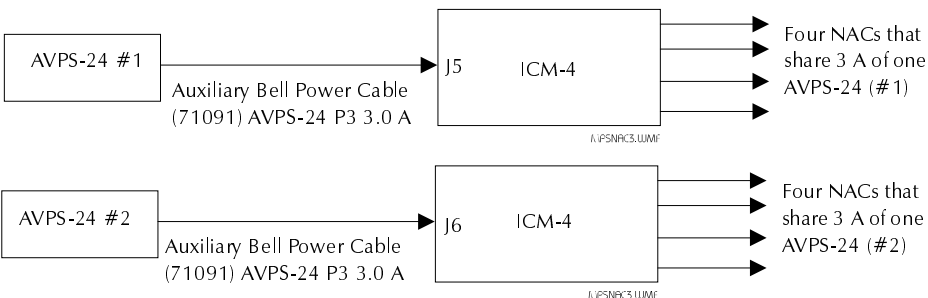
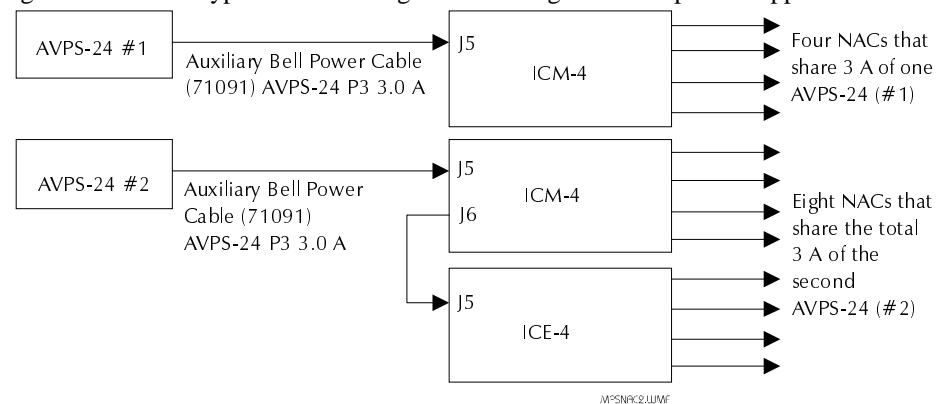

Figure 2-33 AVPS-24 NAC Configuration

Figure 2-34 shows a block diagram that uses two AVPS-24 power supplies to power an ICM-4 or ICE-4. If doing this, cut jumpers JP1 and JP2 located above J5 and J6:

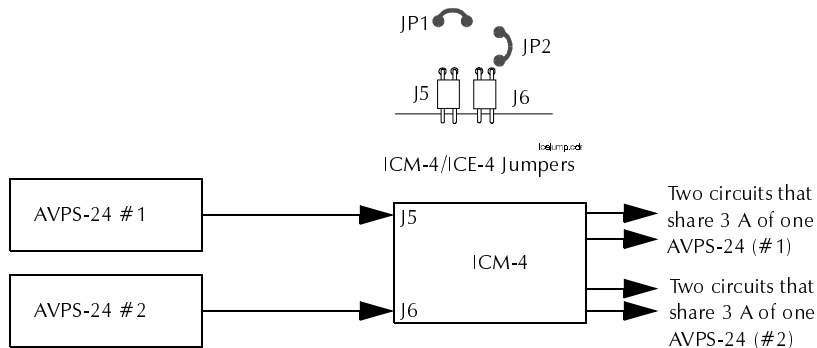

Figure 2-34 AVPS-24 NAC Configuration (Two AVPS-24s)

Field-Wiring an ICM-4 and an ICE-4 (NFPA Style Y and Z)

Guidelines for field-wiring include the following:

- Notification Appliance Circuits (NACs) are supervised, power-limited, and can connect to an energy-limited cable.
- Use only the compatible, UL-listed notification appliances listed in the Device Compatibility Document.
- Wire notification appliances according to the manufacturer's instructions.
- Maximum current per circuit is 3.0 A. Maximum current per module depends on the type of power supply (MPS-400 or AVPS-24).
- Canadian installations require model N-ELR End-of-Line Resistor Assembly (Style Y only).
- Size NAC wiring so the voltage drop does not exceed the minimum rated voltage of the notification appliance used as the last device on the circuit.
- For zone coded applications, refer to the ADT-UZC-256 manual.
- The ICM-4 is California Code programmable (microprocessor Rev. B or higher). To program for California Code, cut diode D35.

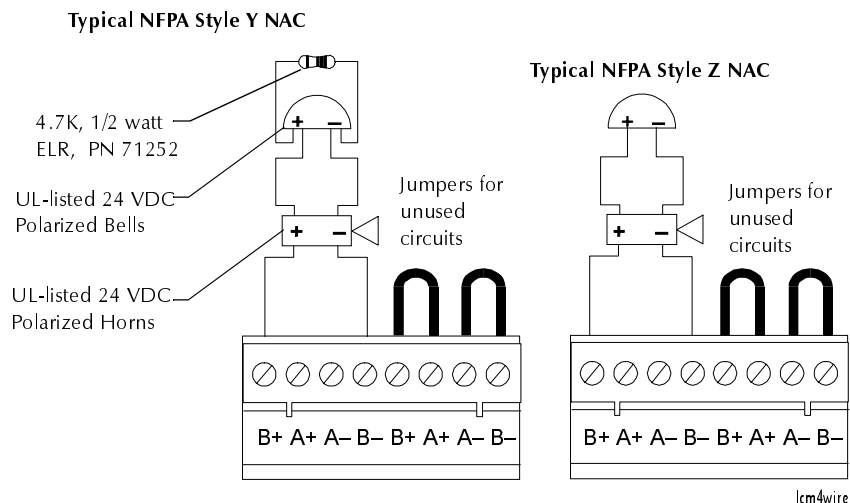

Figure 2-35 Field-Wiring an ICM-4

Positions E, F, G, and H are active only with the ICE-4 installed. You can also install a CRE-4 module on the ICM-4, connected as shown in Figure 2-36:

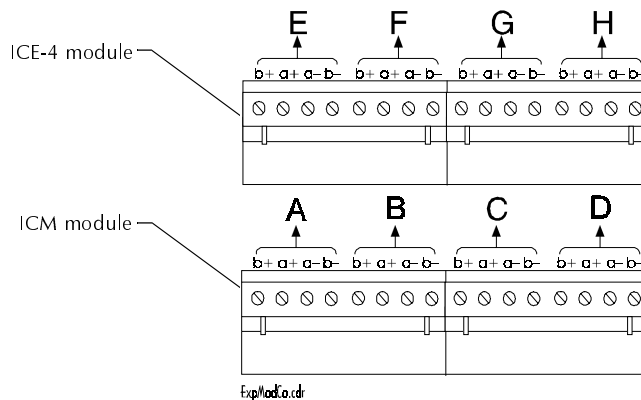

Figure 2-36 Field-Wiring an ICE-4

Field-Wiring a CRM-4 and the CRE-4

CRM-4 and CRE-4 Wiring Guidelines

- These Form-C silver alloy relay contacts are for medium duty switching or pilot duty (Figure 2-37).
- UL contact ratings are 5 A @ 125 VAC (resistive) or 30 VDC (resistive) and 2 A @ 125 VAC (inductive). For more information, refer to Appendix F, UL Power-limited Wiring Requirements.
- Activation of a CRM-4 or CRE-4 relay occurs automatically when an alarm is detected on a selected (programmed) Initiating Device Circuit.
- Positions E, F, G, and H are active only with the CRE-4 board installed.

CRM-4 and CRE-4 Connections

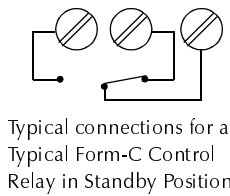

Figure 2-37 shows typical connections for field-wiring a CRM-4/CRE-4 module:

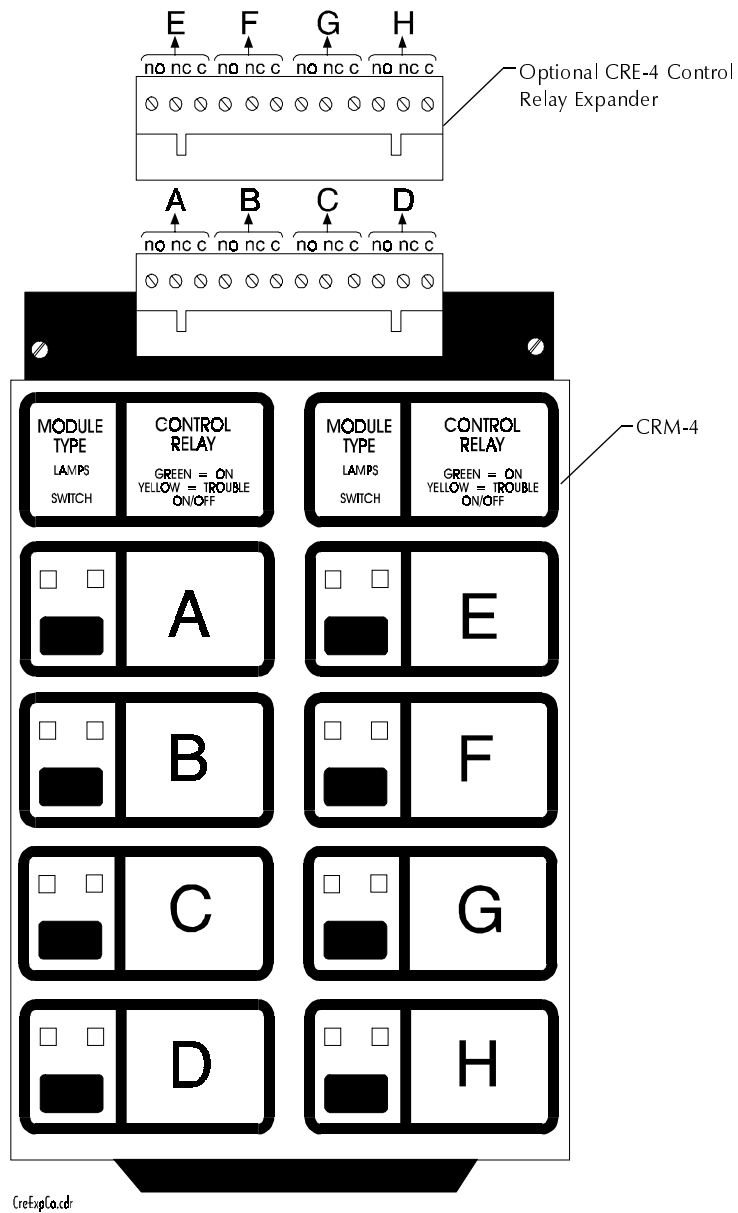

Figure 2-37 Field-Wiring a CRM-4/CRE-4 Module

Field Wiring an Optional AVPS-24 Power Supply

AVPS-24 Wiring Overview

This section covers wiring an AVPS-24. Use TB2 terminals for a power circuit run to M500CH control modules. Table 2-10 lists connections between the AVPS-24 and the MPS-400. For wiring, see Figure 2-38, Figure 2-39, or both.

AVPS-24 Pin	Function	Connect to MPS-400...
TB1-1	Earth ground in	Chassis or earth ground terminal
TB1-2	Secondary power (24 VDC) positive (+) connection	TB1-6 (+)
TB1-3	Secondary power (24 VDC) negative (-) connection	TB1-7 (-)
TB1-4	Primary power (120 VAC) neutral connection	TB-2 (neutral)
TB1-5	Primary power (120 VAC) hot connection	TB1-4 (hot)
TB1-6	Earth ground out	TB1-3 (earth ground)

Table 2-10 AVPS-24 to MPS-400 Connections

AVPS-24 Wiring Diagrams

Plug the Auxiliary Bell Power Harness to the connector J5 on the ICM-4 or the ICE-4 NAC modules as shown in Figure 2-38:

Note: The Auxiliary Bell Power Harness provides 24 VDC special purpose power (unfiltered, unregulated), power-limited (3.0 A maximum) to NAC modules.

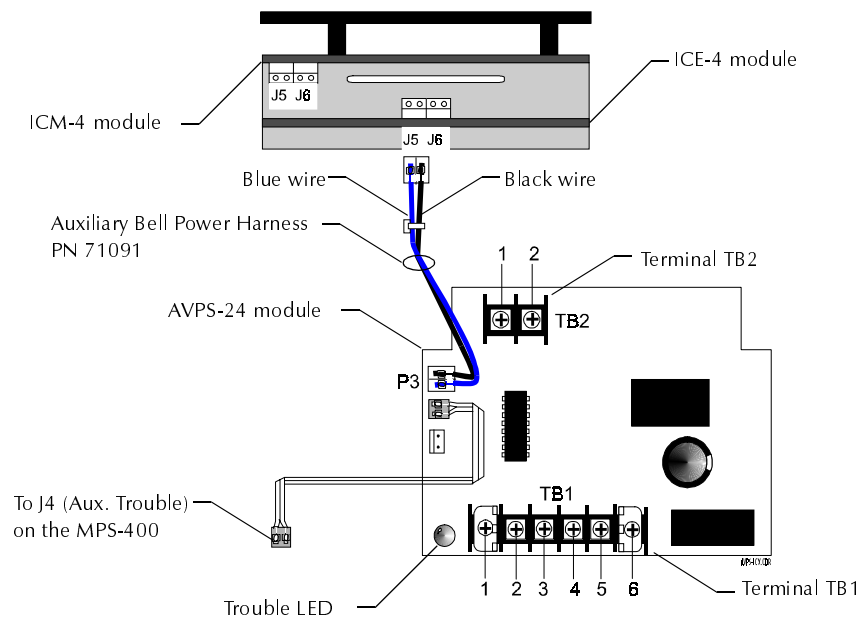

Figure 2-38 Wiring an AVPS-24 to an ICE-4 or an ICM-4

Figure 2-39 shows a block diagram for connecting or changing multiple AVPS-24 power supplies:

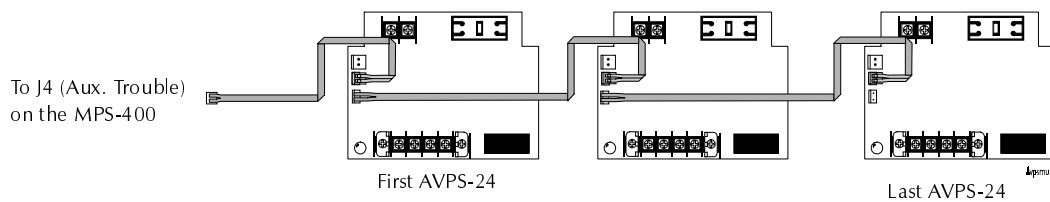

Figure 2-39 Wiring Multiple AVPS-24s

Field Wiring Four-Wire Smoke Detectors (Style B and Style D)

Field Wiring Overview

Note: Refer to the Device Compatibility Document for detector and power supervision relays.

This section shows how to wire initiating devices which require 24 VDC operating power. Figure 2-41 shows wiring for Style D connections and Figure 2-42 shows wiring for Style B connections.

1. Connect the Power Supervision Relay coil (A77-716B) leads to the last detector base 24 VDC screw terminal.
2. Calculate the maximum allowable resistance in the 24 VDC detector power wiring as follows:

$$R_{max} = \frac{(20.6 - V_{om})}{(N)(I_s) + (NA)(I_a) + (I_r)}$$

Where:

- R_{max}** the maximum resistance of the 24 VDC wires.
- V_{om}** the minimum operating voltage of the detector or end-of-line relay—whichever is greater—in volts.
- N** the total number of detectors on the 24 VDC supply circuit.
- I_s** the detector current in standby.
- NA** the number of detectors on the 24 VDC power circuit which must function at the same time in alarm.
- I_a** the detector current in alarm.
- I_r** the end of line relay current.

Figure 2-40 Calculating Max. Allowable Resistance

Field Wiring (Style D)

Note: All connections are supervised and power-limited.

Figure 2-41 shows typical field-wiring for four-wire detectors (Style D):

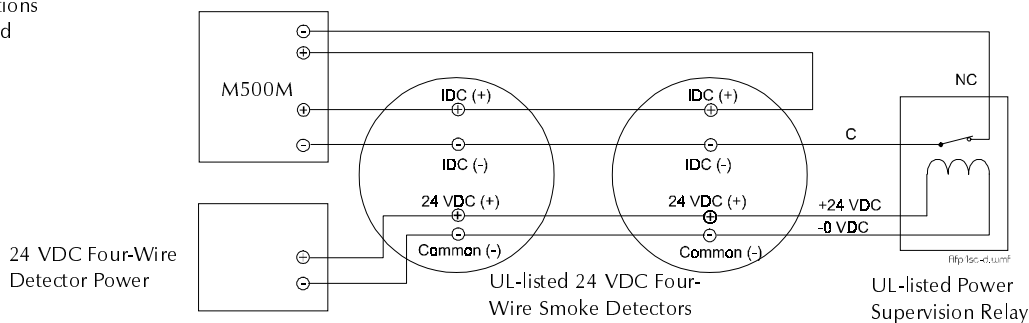

Figure 2-41 Wiring Four-Wire Smoke Detectors (Style D)

Field Wiring (Style B)

Note: All connections are supervised and power-limited.

Figure 2-42 shows typical field-wiring for four-wire detectors (Style B):

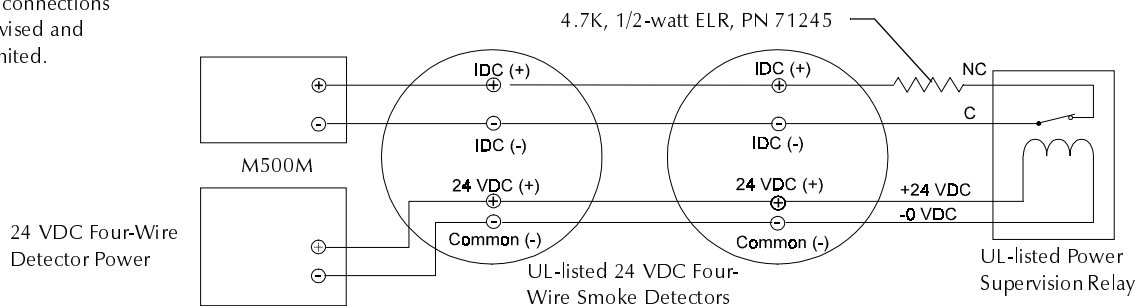

Figure 2-42 Wiring Four-Wire Smoke Detectors (Style B)

Field Wiring the Auxiliary Relay Module (ARM-4)

Overview

Note: For more information, refer to Appendix F, UL Power-limited Wiring Requirements.

This section provides terminal assignments for ARM-4 module control relays K1-K4, which control nonpower-limited circuits. Wiring requirements follow:

- Power-limited and nonpower-limited circuit wiring must remain separated in the cabinet.
- All power-limited circuit wiring must remain at least 0.25 in. away from any nonpower-limited circuit wiring.
- All power-limited and nonpower-limited circuit wiring must enter and exit the cabinet through different knockouts, conduits, or both.

Table 2-11 contains contact ratings for relays K1-K4 on the ARM-4 module:

Resistive Load	Contacts	
	N.O.	N.C.
125 VAC	20 A	10 A
30 VDC	20 A	10 A

Table 2-11 Contact Ratings for K1-K4 on the ARM-4 Module

ARM-4 Terminal Assignments

Figure 2-43 shows terminal assignments for control relays on the ARM-4 module:

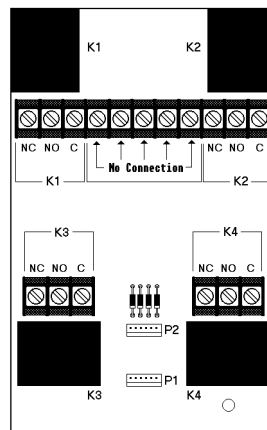

Figure 2-43 ARM-4 Module Terminal Assignments

Field Wiring the MPS-400 Power Supply



Warning: Several sources of power can be connected to the control panel. Before servicing the control panel, disconnect all sources of input power. While energized, the control panel and associated equipment can be damaged by removing and/or inserting cards, modules, or interconnecting cables.

MPS-400 Board

Figure 2-44 shows the terminal blocks, NACs, switches, and connectors used to wire the MPS-400 power supply:

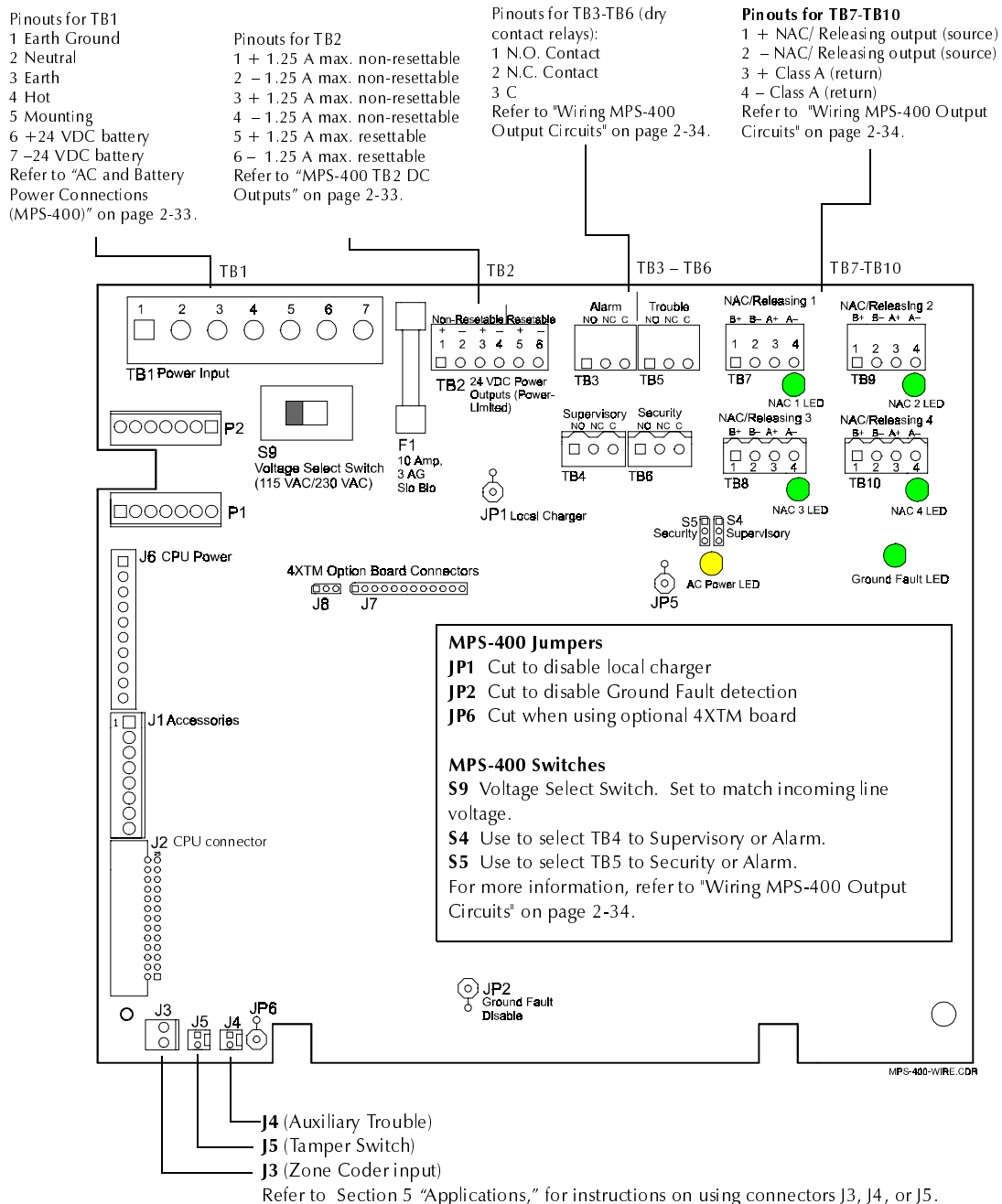

Figure 2-44 MPS-400 Board DC Power Output Connections (MPS-400)

DC Power Output Connections (MPS-400)

MPS-400 terminal TB2 provides three power outputs (each output is power-limited), shown in Figure 2-45:

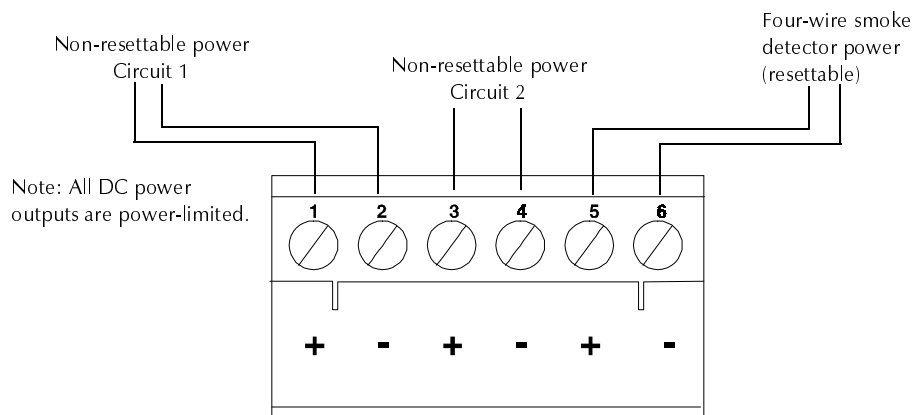

Figure 2-45 MPS-400 TB2 DC Outputs

Non-resettable Power (Circuits 1 and 2) – The MPS-400 provides two 24 VDC filtered, low-noise, non-resettable power, 1.25 A circuits (TB2 terminals 1 and 2 for circuit 1; TB2 terminals 3 and 4 for circuit 2). Use these circuits to power notification appliances, annunciators, and other devices that require low-noise 24 VDC power.

Four-Wire Smoke Detector Power – TB2 terminals 5 (+) and 6 (–) provide 24 VDC filtered, low-noise, resettable power for four-wire smoke detectors.

AC and Battery Power Connections (MPS-400)

Primary power required for the control panel is 120 VAC or 240 VAC, 50/60 Hz, 3 A. Overcurrent protection for this circuit must comply with Article 760 of the National Electrical Code (NEC) and/or local codes. Use 14 AWG or larger wire with a 600-volt rating.



Warning: Before applying AC power, set the 115V/230V Voltage Select Switch(S9) to match the incoming AC line voltage.

Caution: Battery contains sulfuric acid which can cause severe burns to the skin and eyes, and can destroy fabrics. If contact is made with sulfuric acid, immediately flush skin or eyes with water for 15 minutes and seek immediate medical attention.

Once the system is installed, calculate the proper battery rating (Refer to Appendix G, *Power Supply Calculations*). Observe polarity when connecting batteries. Connect the battery cable to terminal TB1 on the MPS-400. Because AC and battery wiring are not power-limited, maintain at least 0.25 in. between power-limited and nonpower-limited wiring. For more information on power limiting, refer to Appendix F, UL Power-limited Wiring Requirements.

Figure 2-46 shows the terminal connections to TB1 on the MPS-400:

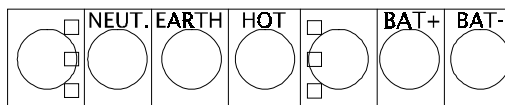

Figure 2-46 MPS-400 Terminal TB1 Connections

Wiring MPS-400 Output Circuits

Notification Appliance Circuits (NACs). The MPS-400 provides four NACs (Style Y or Z). Each circuit can provide 2.5 A of current—but the total current drawn from the MPS-400 cannot exceed 6.0 A (refer to Table G-2). Use UL-listed 24 VDC notification appliances only. Figure 2-47 shows MPS-400 NAC/releasing terminals and typical connections:

Note: Output circuits are supervised and power-limited. Refer to Device Compatibility Document for a list of compatible notification appliances.

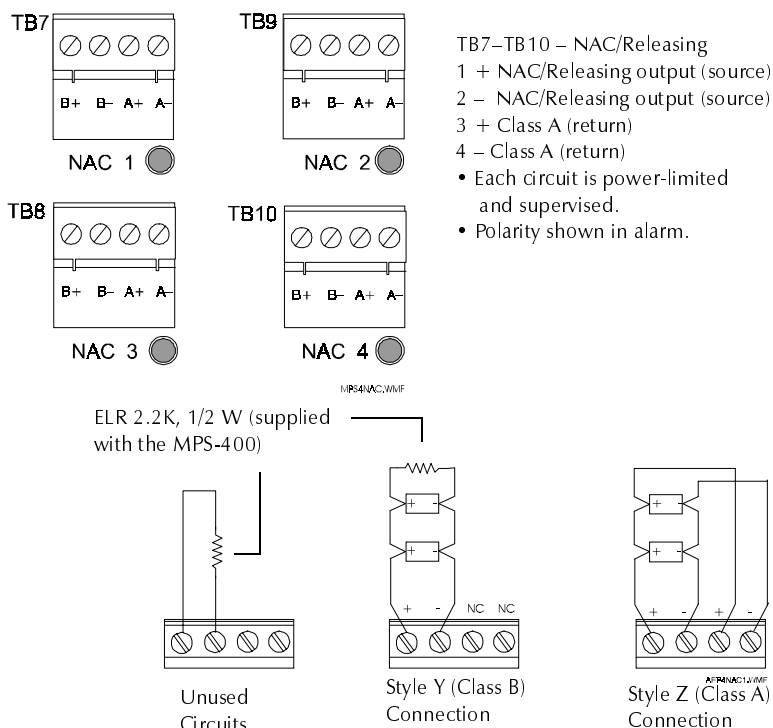

Figure 2-47 Notification Appliance/Releasing Circuit Connections

Releasing Circuits. You can program any Notification Appliance Circuit as a releasing circuit. Refer to *Releasing Circuits* in the Unimode 400 Programming Manual. Refer to the Device Compatibility Document, for a list of compatible releasing devices.

Standard Relays. The control panel provides a set of Form-C alarm and a set of Form-C trouble contacts rated for 2.0 A @ 30 VDC (resistive). The control panel also provides a Form-C Supervisory contact and a Form-C Security contact rated for 2.0 A @ 30 VDC (resistive). Supervisory and Security contacts can be set to Alarm contacts using switches SW4 and SW5. Figure 2-48 shows the MPS-400 relay outputs and switches:

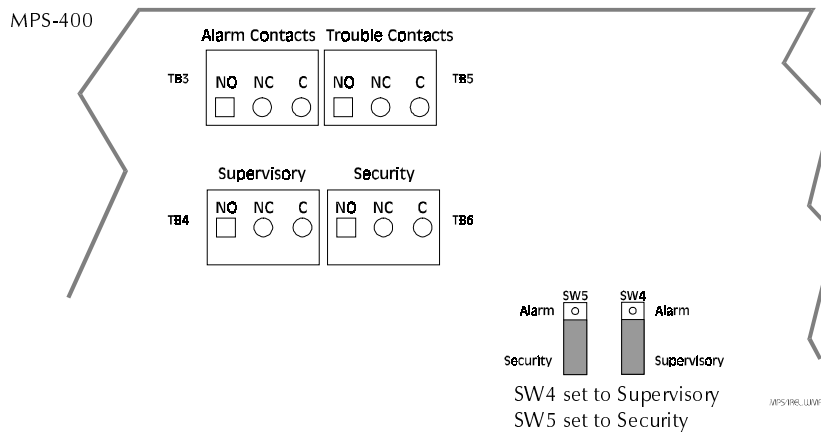

Figure 2-48 MPS-400 Relay Connections

Installing Remote Printers and CRTs

Remote Printers

The PRN-4 remote printer prints a copy of all status changes within the control panel and time-stamps the printout with current time of day and date. The PRN-4 provides 80 columns of data on standard 9" by 11" tractor-feed paper. This section contains information for setting the printer options and connecting a printer to the control panel.

Note: You can also use the EIA-232 printer interface with EDP-listed equipment, such as personal computers, to monitor the control panel for supplementary purposes.

Setting PRN-4 Options

Refer to the documentation supplied with the PRN-4 for instructions on using the printer menu controls. Set the printer options (under the menu area) according to the settings listed in Table 2-12:

Option	Setting
L/R Adjust	0
Font	HS Draft
LPI	6 CPI
ESC Character	ESC
Bidirectional Copy	ON
CG-TAB	Graphic
Country	E-USE ASCII
Auto CR	1S
Color Option	Not Installed
Formlen	
Lines	6 LPI-60
Standard	Executive 10.5"
CPI	10 CPI
Skip	0.5
Emulate	Epson
I/O	
Buffer	36K
Serial	
Baud	2400
Format	7 Bit, Even, 1 Stop
Protocol	XON/XOFF
Character Set	Standard
S1. Zero	On
Auto LF	Off
MENULOCK	
PAPER	
BIN 1	12/72"
BIN 2	12/72"
SINGLE	12/72"
PUSH TRA	12/72"
PULL TRA	12/72"
PAP ROLL	12/72"
PAPOPT	No

Table 2-12 PRN-4 Setup Options

Installing a PRN-4 Remote Printer

Remote printers require a 120 VAC, 50/60 Hz primary power source and a secondary power source (battery backup). Because a secondary power source is not provided, use a separate Uninterruptable Power Supply (UPS) that is UL-listed for Fire Protective Signaling. Install the remote printer to the control panel as follows:

1. Make a custom cable for connecting the printer EIA-232 port to CPU-400 TB1 (Printer) using the wiring specifications shown in Figure 2-49:

PRN (EIA-232)	PRN (EIA-232) CPU (TB1)
TX (Pin 3)	TB1-1
RX (Pin 2)	TB1-2
REF (Pin 7)	TB1-3

Figure 2-49 PRN-4 to CPU Cable Wiring Specifications

Note: Outputs are power-limited but are not supervised.

2. Connect the cable between the CPU and the PRN-4 through an EIA-232 interface as shown in Figure 2-50:

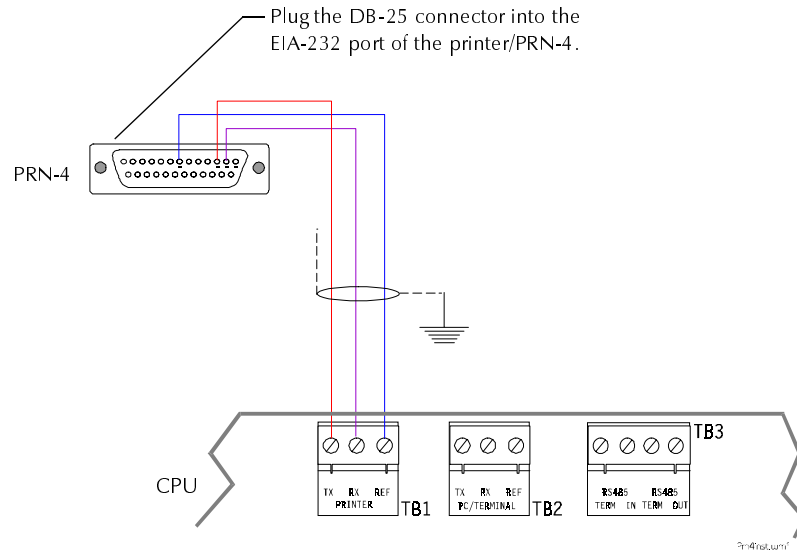

Installing a Keltron Printer

Connect the printer cable to terminal TB1 on the CPU as shown in Figure 2-51:

1. Connect the DB-25 connector to the EIA-232 port of the Keltron printer.
2. Connect DC power from terminal TB2 on the MPS-400.

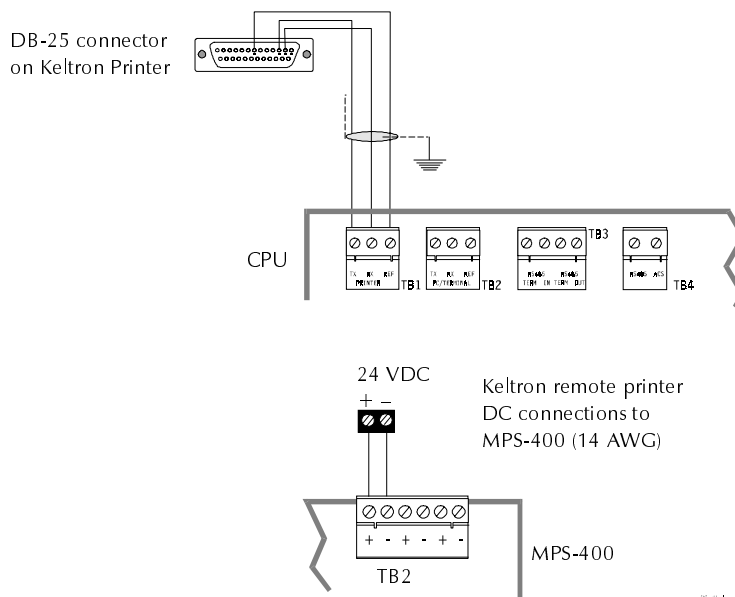

Figure 2-51 Keltron Printer Connections

Setting up the Keltron Printer

Set up a Keltron printer as follows:

1. Connect the printer with overall foil/braided-shield twisted-pair cable suitable for EIA-232 applications (typically 50 feet maximum between the printer and the control panel is recommended). The printer communicates using the following protocol:
 Baud Rate: 2400
 Parity: Even
 Data bits: 7
2. Set the printer DIP switches SP1 and SP2 according to settings in Table 2-13:

SP1 settings:

DIP Switch SP1	On	Off
SP1-1		X
SP1-2	X	
SP1-3		X
SP1-4	X	
SP1-5		X
SP1-6	X	
SP1-7	X	
SP1-8		X

SP2 settings

DIP Switch SP2	On	Off
SP2-1		X
SP2-2		X
SP2-3		X
SP2-4	X	
SP2-5		X
SP2-6		X
SP2-7	X	
SP2-8		X

Table 2-13 Keltron DIP Switch Settings

Installing a CRT-2

Connect a CRT-2 to the CPU as follows:

1. Connect one end of the cable to terminal TB2 on the CPU.
2. Plug the DB-25 connector to the EIA-232 port of the CRT-2 (Table 2-14).

Note: For terminal interface and protocol information, refer to Appendix E.

Connect	To CPU terminal...
TX (pin 3)	TB2-1
RX (pin 2)	TB2-2
REF (pin 7)	TB2-3

Table 2-14 CRT-2 to CPU Connections

Figure 2-52 shows typical connections between a CPU and a CRT-2:

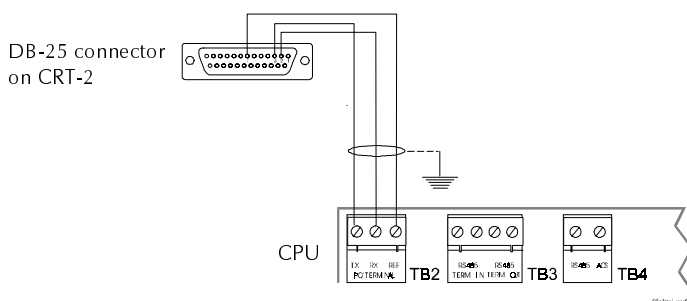

Figure 2-52 Connecting a CRT-2

Connecting Multiple Printers, CRTs, or CRT/PRN Combination

Connecting Multiple Printers, CRT-2s, or a CRT-2/PRN Combination requires changing the CRT-2 setup using the F1 (Quick) menu:

- Set Host/Printer=EIA/AUX.
- Set EIA Data Format=8/1/N.
- If the Aux device is a printer, set the Printer and AUX Data Format=7/1/E.
- If the AUX device is a second CRT-2, set the AUX Data Format=8/1/N.

Note: For detailed information on setting up the CRT-2, refer to Appendix E, Terminal Interface Protocol.

Connect multiple devices as shown in Figure 2-53:

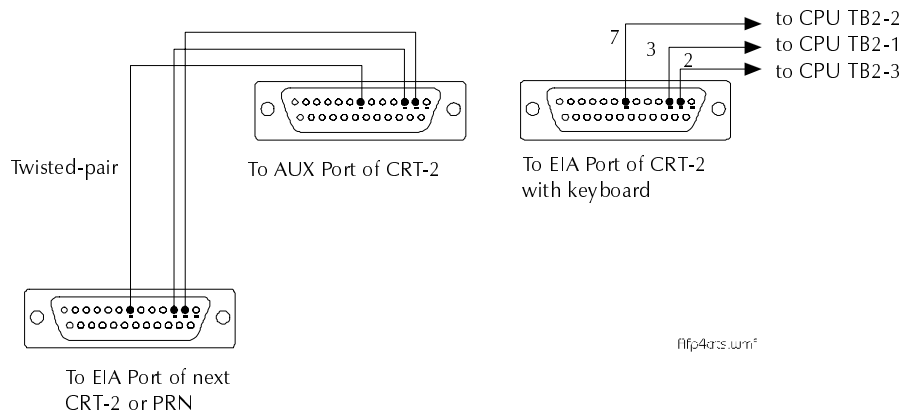

Figure 2-53 Connecting Multiple Printers, CRTs, or CRT/PRN Combinations

Wiring a Signaling Line Circuit (SLC)

Overview of SLC Wiring

Communication between the control panel and intelligent and addressable initiating, monitor, and control devices takes place through a Signaling Line Circuit (SLC). You can wire an SLC loop to meet the requirements of NFPA Style 4, Style 6, or Style 7 circuits. This section covers the topics outlined in Table 2-15:

Topics	Refer to...
Setting an Address for an M500M or M500CH Module	Figure 2-67 on page 2-49.
Methods for terminating wiring leaving the control panel	"SLC Shield Termination" on page 2-42.
Wire Requirements for Two-Wire SLC	"Wire Requirements for a Two-Wire SLC" on page 2-43, which covers: Loop resistance for a Two-Wire SLC. Total wiring length for a Two-Wire SLC. Typical Wiring for a Two-Wire SLC.
Wire Requirements for Four-Wire SLC	"Wire Requirements for a Four-Wire SLC" on page 2-45, which covers: Loop resistance for a Four-wire SLC. Total wiring length for a Four-wire SLC. Typical Wiring for a Four-Wire SLC.
Wiring an M500X Isolator Module	"Wiring an Isolator Module (M500X)" on page 2-48, which covers: Description of an M500X Module. Isolating a Branch of a Two-Wire SLC.
Wiring a Conventional Initiating Device Circuit (IDC)	"Wiring an IDC with M500M Modules" on page 2-49, which covers: Description of Monitor Modules (M500M, M502M, M501M). Wiring a Two-Wire or Four-Wire IDC.
Wiring Notification Appliance Circuits (NACs)	"SLC Wiring with M500CH Modules" on page 2-55, which covers: Description of Control Modules (M500CH). Wiring an M500CH as Form-C Relay. Wiring a Two-Wire (Style Y). Wiring a four-wire NAC (Style Z).
Wiring an ADT-BGX-101L Addressable Pull Station	"SLC Wiring with an Intelligent Detector" on page 2-60, which covers wiring an ADT-BGX-101L in an SLC.
Wiring an Intelligent Detector	"SLC Wiring with an ADT-BGX-101L Addressable Manual Pull Station" on page 2-61, which covers wiring an Intelligent Detector in an SLC.

Table 2-15 SLC Wiring Topics

SLC Devices

Note: Maximum wiring distance of an SLC loop:
 Style 4 10,000 ft. (12 AWG)
 Style 6, 7 10,000 ft. (12 AWG) total twisted-pair.

Communication with intelligent and addressable initiating, monitor, and control devices takes place through a Signaling Line Circuit (SLC). You can wire an SLC to meet the requirements of NFPA Style 4, Style 6, or Style 7 circuits. Table 2-16 contains descriptions of devices connected to an SLC:

Type of Device	SLC Function
Isolator Modules (M500X)	Allows a zone of detectors and modules to be electrically isolated from the remainder of the loop, which lets critical loop components function if a circuit fails. M500X modules are required for NFPA Style 7 circuits.
Addressable Monitor Modules (M500M series)	Allows the control panel to monitor entire circuits of conventional, alarm initiating devices, such as manual pull stations, detectors, waterflow and supervisory devices. The ADT-BGX-101L (a type of monitor module) provides point annunciation of manual pull stations.
Control Modules (M500CH series)	Allows the control panel to selectively activate Notification Appliance Circuits (NACs) or Form-C output relays.
Intelligent Detectors	Allows the control panel to communicate with intelligent ionization, photoelectric, and thermal detectors on the loop.

Table 2-16 SLC Devices

Control Panel Capacity

Note: Refer to the installation drawings supplied with each loop device for rating and specification information.

Each control panel has the capacity to support up to 198 intelligent detectors, and an additional combination of up to 198 addressable pull stations, control modules and monitor modules; and up to 68 internal circuits/relays as shown in Figure 2-54:

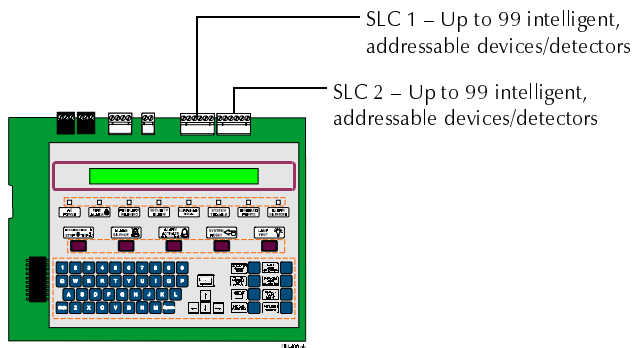

Figure 2-54 Unimode 400 Capacity

SLC Performance

SLC performance depends on the type of circuit: Style 4, Style 6, or Style 7. Table 2-17 lists the trouble conditions that result when a fault exists on an SLC.

Fault in Loop	Style 4	Style 6	Style 7
Open	Trouble	Alarm/Trouble	Alarm/Trouble
Ground	Alarm/Trouble	Alarm /Trouble	Alarm/Trouble
Short	Trouble	Trouble	Alarm/Trouble
Short and open	Trouble	Trouble	Trouble
Short and ground	Trouble	Trouble	Alarm/Trouble
Open and ground	Trouble	Alarm /Trouble	Alarm/Trouble
Communications loss	Trouble	Trouble	Trouble
<ul style="list-style-type: none"> • Trouble indicates a trouble signal will be generated at the control panel during the abnormal condition. • Alarm/Trouble indicates an alarm signal can be transmitted to the control panel during the abnormal condition. • SLC operation meeting Style 7 requirements isolates entire physical zones on the SLC from faults that occur within other areas of the SLC. 			

Table 2-17 SLC Performance

SLC Shield Termination

Overview. All wiring leaving the control panel must be shielded. Figure 2-55, Figure 2-56, and Figure 2-57 show three methods of wiring termination, depending on the type of conduit used: a) no-conduit, b) full-conduit, and c) partial-conduit.

No-Conduit Shield Termination. Do not allow the shield drain wire to enter the system cabinet. Connect the drain wire to the outside of the cabinet using a cable connector as shown in Figure 2-55:

Note: Scrape paint away from the cabinet to make good electrical connections.

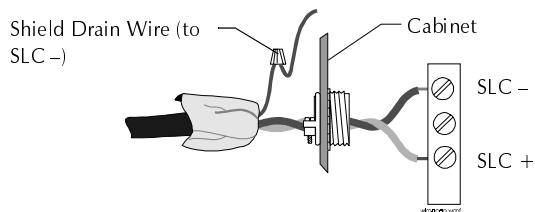

Figure 2-55 Shield Termination – No Conduit

Full-Conduit Shield Termination. For Style 6 or Style 7 field-wiring of the SLC, connect each end of the shield to the negative side of the respective channel as shown in Figure 2-56:

Note: The shield drain wire must be connected to the negative (-) side of the loop. Do not let the shield drain wire or the shield foil touch the system cabinet.

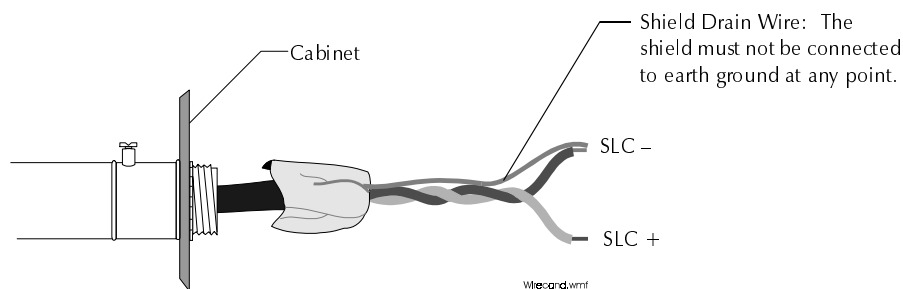

Figure 2-56 Shield Termination – Full Conduit

Partial-Conduit Shield Termination. Do not allow the shield drain wire to enter the system cabinet or the conduit. Connect the drain wire to the termination point of the conduit run.

Note: If the length of conduit from the control panel cabinet exceeds 20 feet, terminate the shield as shown. If using a metal box, you must use a metal conduit.

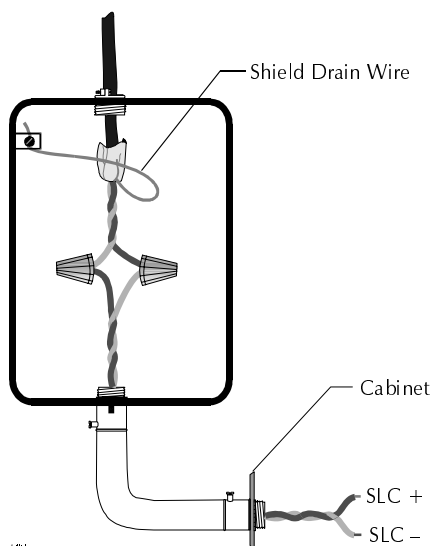
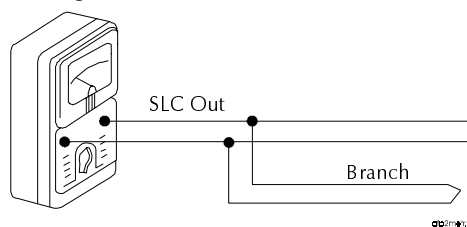

Figure 2-57 Shield Termination – Partial Conduit

Wire Requirements for a Two-Wire SLC

Measuring Loop Resistance for a Two-Wire SLC

The total DC resistance from panel to branch end cannot exceed 40 ohms. Measure DC resistance as shown in Figure 2-58:



Note: For detailed wiring requirements, refer to Appendix B.

Figure 2-58 Measuring DC Resistance of a Two-Wire SLC

1. Short the termination point of one branch at a time. Measure the DC resistance from the beginning of the loop to the end of that particular branch.
2. Repeat this procedure for all remaining branches in the SLC.

Measuring Total Wire Length for a Two-wire SLC

The total length of wire (12 AWG) in a two-wire SLC cannot exceed 10,000 feet. Find the total length of wire in the SLC by summing the wire lengths on each branch of the SLC. Figure 2-59 shows how to find the total length wire in a typical two-wire SLC:



Caution: Terminate shield drain wire according to the instructions in "SLC Shield Termination" on page 2-42.

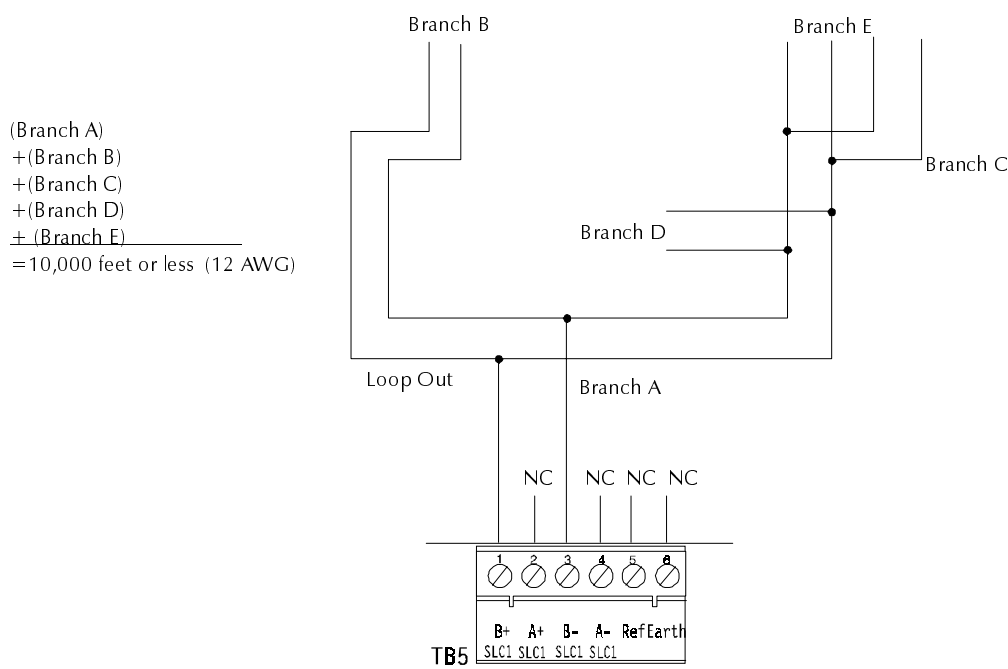

Figure 2-59 Measuring the Total Length of Wire in a Two-Wire SLC

Figure 2-60 shows typical wiring of a supervised and power-limited two-wire SLC that meets NFPA 72 Style 4 requirements. Table 2-18 contains SLC connections shown in Figure 2-60.

Connection	SLC 1	SLC 2
SLC Out	TB5-1 (+) TB5-3 (-)	TB6-1 (+) TB6-3 (-)

Table 2-18 Two-Wire SLC Connections.



Caution: Terminate shield drain wire according to the instructions in "SLC Shield Termination" on page 2-42.

B501B Base – for use with 1551/2551, 1251/2251, 3251, and 5551 Series intelligent detectors

Note: M500X devices are not required to meet NFPA Style 4. You can install a maximum of 25 devices, detectors, and modules between isolator modules, or isolator detector mounting bases

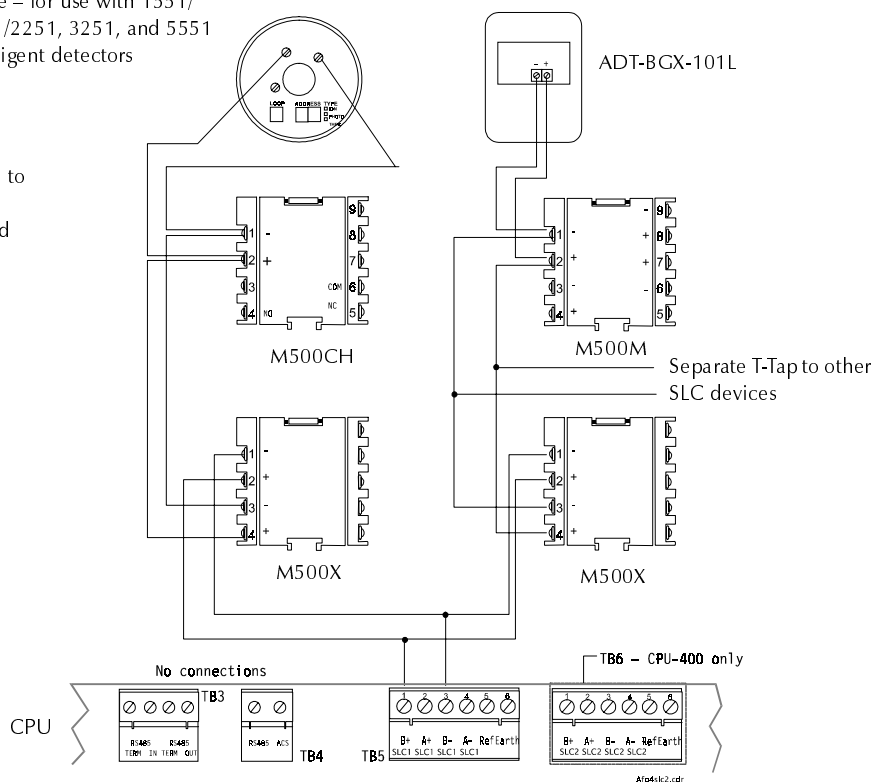

Figure 2-60 Typical Two-Wire SLC Circuit (Style 4)

Wire Requirements for a Four-Wire SLC

Measuring Loop Resistance for a Four-Wire SLC

Note: For detailed wiring requirements, refer to Appendix B.

The total DC resistance of the SLC pair cannot exceed 40 ohms. Measure DC resistance as shown in Figure 2-61.

1. Disconnect the SLC Out and SLC Return at the control panel.
2. Short the two leads of SLC Return.
3. Measure the resistance across the SLC Out leads (Figure 2-61).

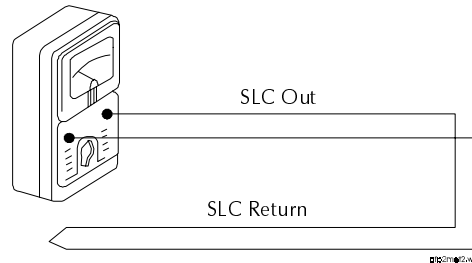

Figure 2-61 Meter Leads for Measuring a Four-wire SLC

Measuring Total Wire Length for a Four-wire SLC

The total length of wire (12 AWG) in a four-wire SLC cannot exceed 10,000 feet. Figure 2-62 identifies the output and return loops from SLC terminal TB5 on the CPU:

Note: T-tapping is not allowed on a four-wire SLC.

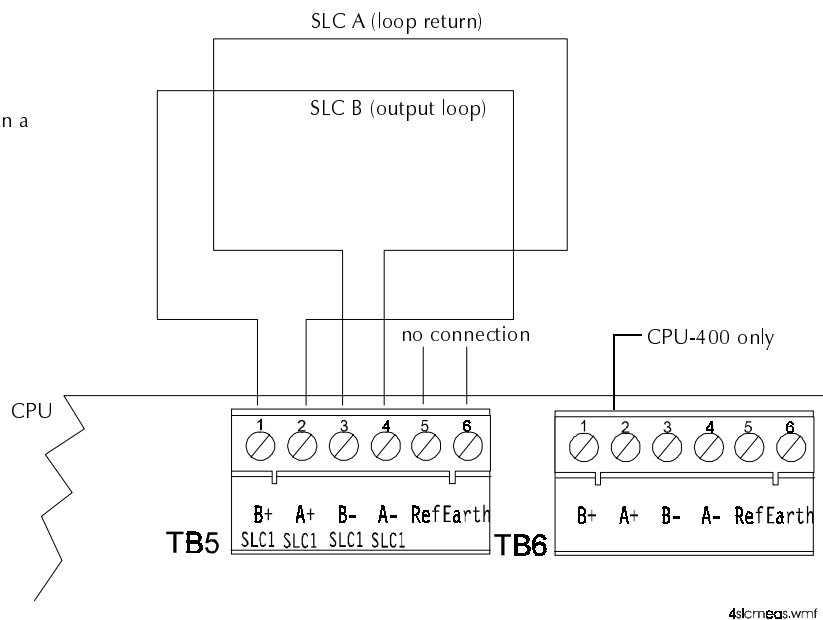

Figure 2-62 Measuring the Wire Length – Four-Wire SLC

Style 6 Wiring Overview Figure 2-63 shows typical wiring for a supervised and power-limited four-wire SLC that meets NFPA 72 Style 6 requirements. Table 2-19 contains the SLC connections for this circuit:

Connection	SLC 1	SLC 2
SLC Out	TB5-1 (+) TB5-3 (-)	TB6-1 (+) TB6-3 (-)
SLC Return	TB5-2 (+) TB5-4 (-)	TB6-2 (+) TB6-4 (-)

Table 2-19 SLC Connections

Style 6 Wiring Diagram Figure 2-63 shows typical wiring for a Style 6 SLC:

Note: B501B – For use with 1551/2551, 1251/2251, 5551, and 3251 Series intelligent detectors.

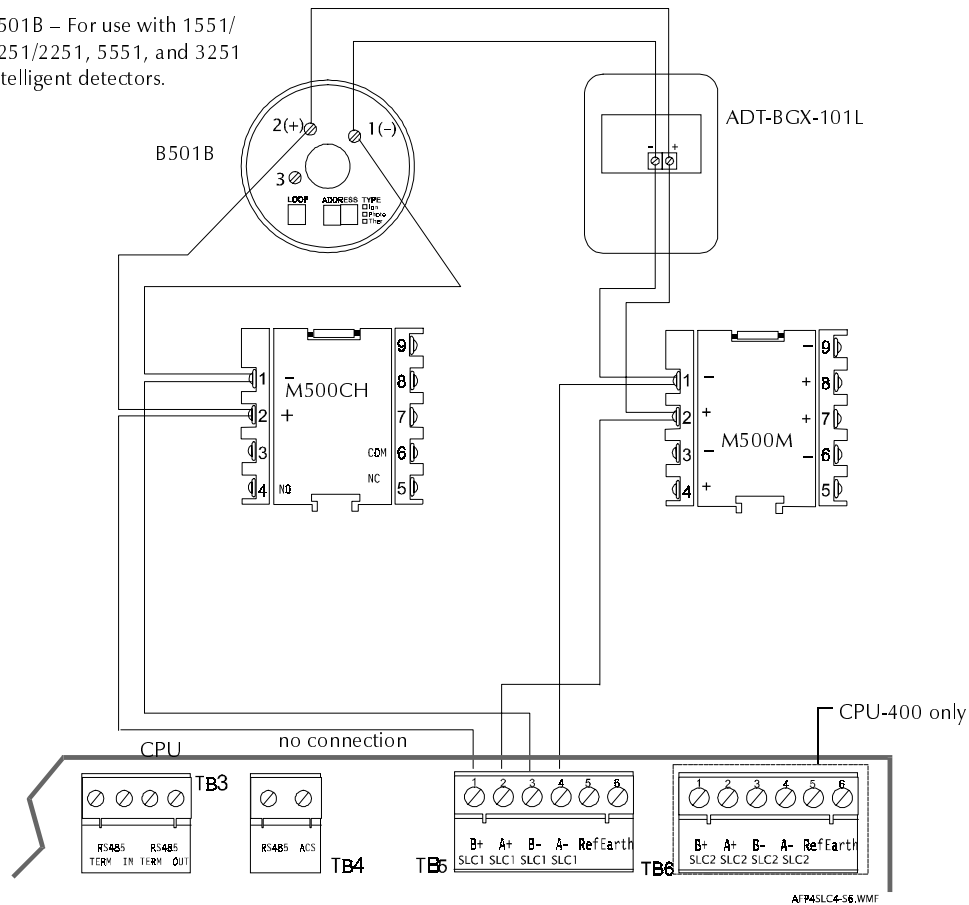

Figure 2-63 Typical Four-Wire SLC Circuit (Style 6)

Style 7 Wiring Overview Obtain Style 7 operation by using Isolator Bases (B524BI or B224BI) with each detector flanking M500M modules with M500X modules (Figure 2-64). Wire-to-wire shorts on the SLC do not prevent the control panel from receiving alarm signals.

Do not T-Tap or branch a Style 7 four-wire SLC. Ratings and characteristics are identical to a NFPA Style 6 four-wire SLC. Table 2-20 shows connections between the SLC and CPU terminal TB-5:

Connect...	To CPU...
SLC Out	TB5-1 (+) TB5-3 (-)
SLC Return	TB5-2 (+) TB5-4 (-)

Table 2-20 SLC to CPU Connections

Style 7 Wiring Diagram Figure 2-64 shows typical wiring for a Style 7 SLC with M500X modules flanking M500M modules:

Note: Enclose all wiring between a manual pull station and M500X modules in conduit.

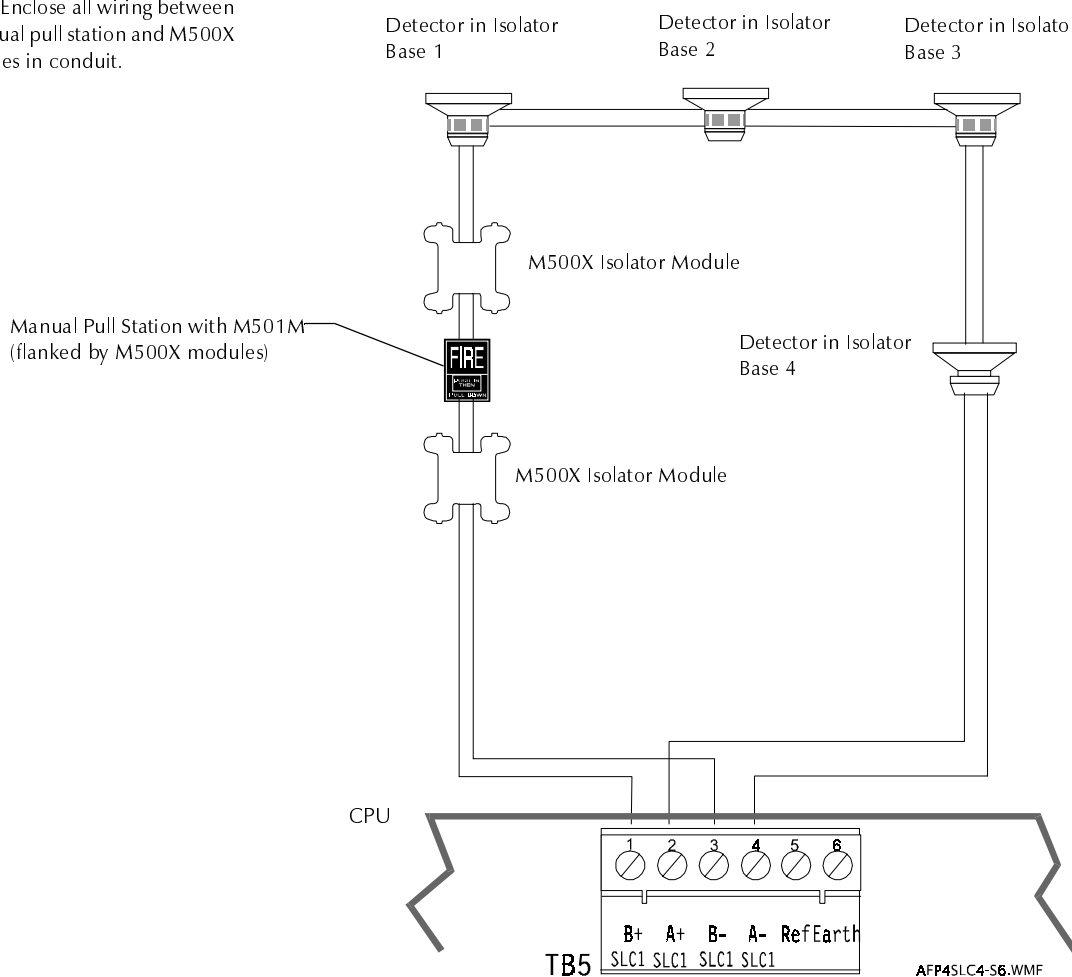

Figure 2-64 Style 7 Four-Wire SLC using M500X Modules

Wiring an Isolator Module (M500X)

M500X Overview

Use a loop Isolator Module (M500X) to protect critical elements of the SLC from faults on other branches or sections of the SLC. The M500X continuously monitors the circuit connected to terminals 3 (-) and 4 (+). Upon power-up, an integral relay latches. The M500X periodically pulses the coil of this relay. A short circuit on the SLC resets the relay. The M500X detects the short and disconnects the faulted SLC branch by opening the positive side of the loop (terminal 4). This isolates the faulty branch from the remainder of the loop. Once the fault is removed, the M500X automatically reapplies power to the SLC branch.

You can connect a maximum of 25 devices between isolator modules. During a fault condition, the control panel registers a trouble condition for each addressable device which is isolated on the SLC segment or branch.

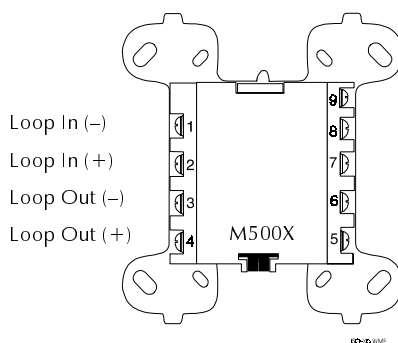

Figure 2-65 Isolator Module (M500X) Terminal Connections

Isolating a Branch of a Two-Wire SLC

A short circuit on the SLC Style 4 branch (connected to M500X terminals 3 and 4) causes the branch to be disconnected and isolated from the remainder of the SLC. This prevents a communication problem with all other addressable devices on the branches (labeled “Continuation of the SLC” in Figure 2-66) and all addressable devices on the isolated branch will report a trouble condition at the CPU.

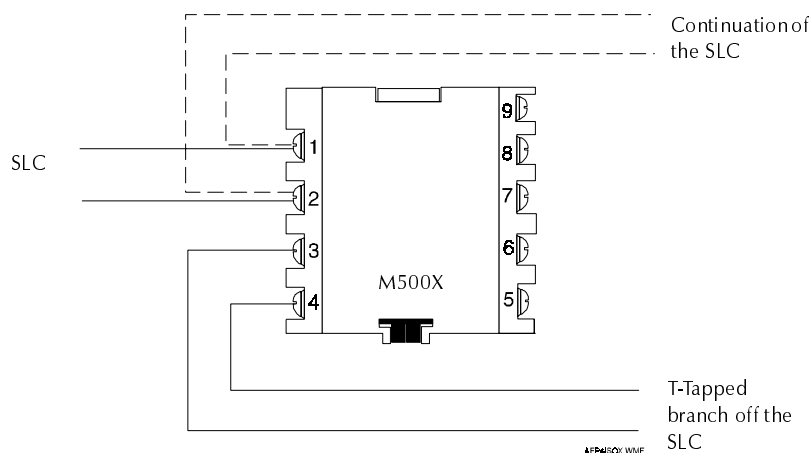

Figure 2-66 Wiring an M500X

Wiring an IDC with M500M Modules

Overview of Monitor Modules (M500M Series)

The M500M Monitor Module is an addressable module that monitors conventional contact-type, alarm, supervisory, security, alert, or trouble initiating devices. You can wire a supervised M500M circuit as an NFPA Style B or Style D IDC.

- NFPA Style B Initiating Device Circuit – see Figure 2-68 and Figure 2-69.
- NFPA Style D Initiating Device Circuit – see Figure 2-70 and Figure 2-71.
- There are three models of M500M Series monitor modules as follows:

M500M – Use M500M modules for wiring Style B and Style D IDCs.

M502M – The M502M Monitor Module is an addressable module used to monitor a single Initiating Device Circuit of smoke detectors. Use M502M modules to monitor conventional, two-wire smoke detectors. The M502M requires an additional connection of 24 VDC filtered, low-noise and resettable power on M502M Terminals 3 (–) and 4 (+).

M501M (Style B circuits only) – The M501M is a miniature addressable module that is functionally and electrically identical to an M500M Monitor Module. Because of the smaller size, an M501M is ideally suited for mounting directly in the electrical box of a monitored contact-type device.

Wiring an M500M Module

Connect the SLC wiring to M500M terminals 1 (–) and 2 (+). The M500M takes one module address on the SLC. Use the rotary switches on the M500M to set the module to the required SLC address. (For example, the M501M shown in Figure 2-67 is set to SLC address 04.)

Note: Testing an M500M – An M500M includes a magnetic test switch located near the center front of the module.

Setting Rotary Switches

- 1) Factory preset is address 00.
- 2) Use a screwdriver to set a rotary switch to the desired module address.

For example, the switches shown are set to address 04.

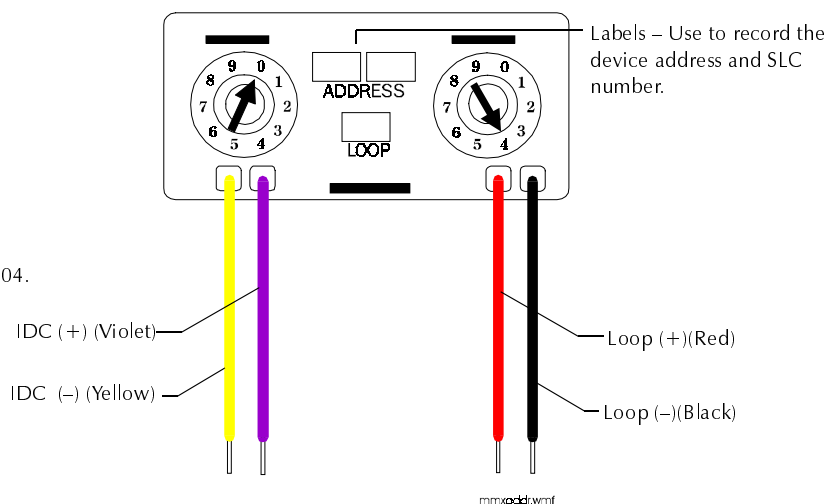

Figure 2-67 Setting a M500M Series Module (M501M shown) Address

Note: Installation notes for M502M modules are listed with the M502M installation drawings.

M500M and M501M Installation Notes. When installing M500M and M501M modules, note the following:

1. The IDC is supervised and current-limited to 210 microamperes @ 24 VDC (nominal).
2. The IDC provides the following services (do not mix):
 - Fire Alarm Service.
 - Automatic/Manual Waterflow Alarm Service with normally open contact devices.
 - Sprinkler Supervision with normally open contact devices.
 - Security Service.
3. Maximum IDC wiring resistance is 20 ohms.

Wiring an NFPA Style B IDC with M500Ms

Figure 2-68 shows typical wiring using M500M modules to wire a Style B IDC. Maximum IDC resistance is 20 ohms. Refer to the Device Compatibility Document for detector and power supervision relays.

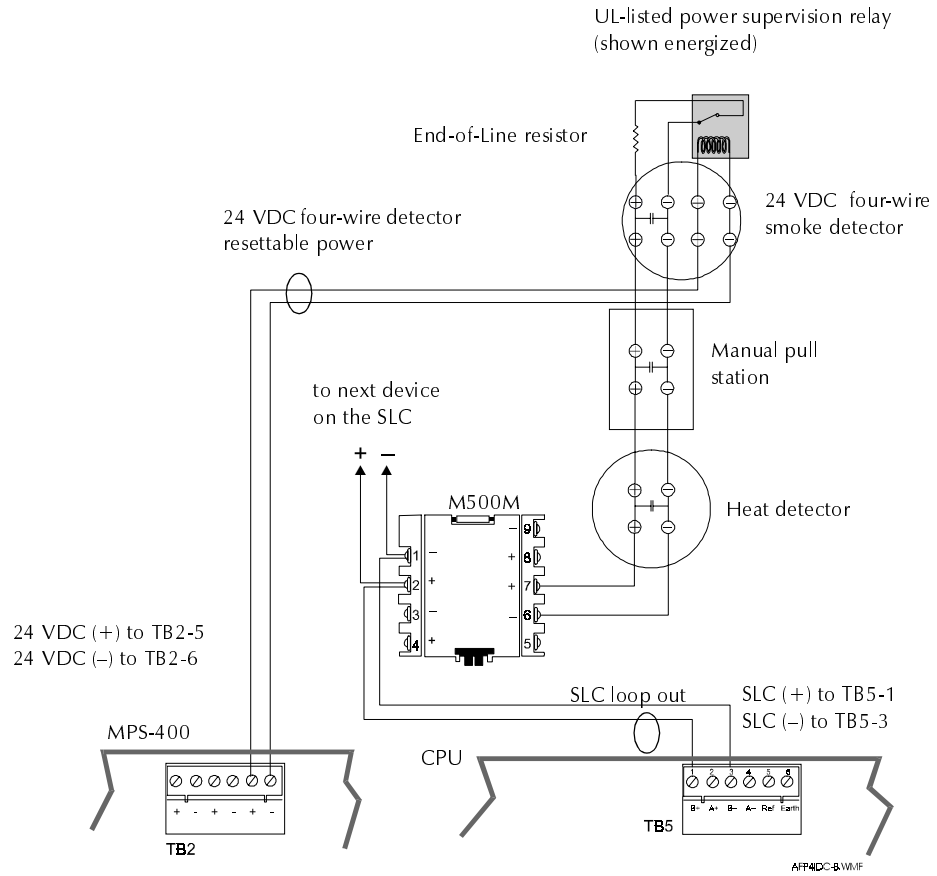

Figure 2-68 Typical Style B (Class B) IDC Wiring with M500Ms

Wiring an NFPA Style B IDC with M502Ms

Figure 2-69 shows typical wiring for a supervised and power-limited NFPA Style B IDC using M502M modules. For more information, refer to the M502M Installation Instructions, Document M500-03-00.

Wiring guidelines for this IDC are:

- Maximum Initiating Device Circuit (IDC) resistance is 25 ohms.
- Maximum alarm current is 90 mA.
- Maximum detector standby current is 2.4 mA.

Note: Refer to the Device Compatibility Document for detector and power supervision relays.

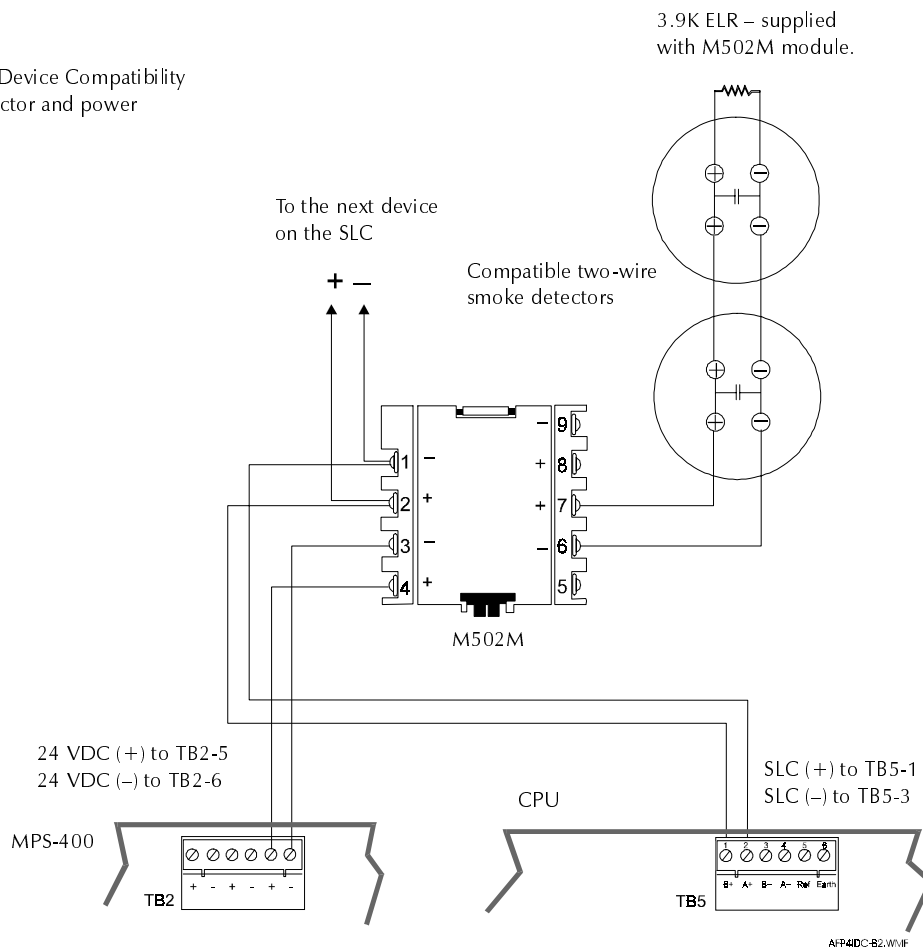

Figure 2-69 Typical Style B (Class B) IDC Wiring with M502Ms

Wiring an NFPA Style B IDC with M500Ms

Figure 2-70 shows typical wiring for a supervised and power-limited NFPA Style D (Class A) IDC using M500M modules. Maximum IDC resistance is 20 ohms.

Note: Refer to the Device Compatibility Document for detector and power supervision relays.

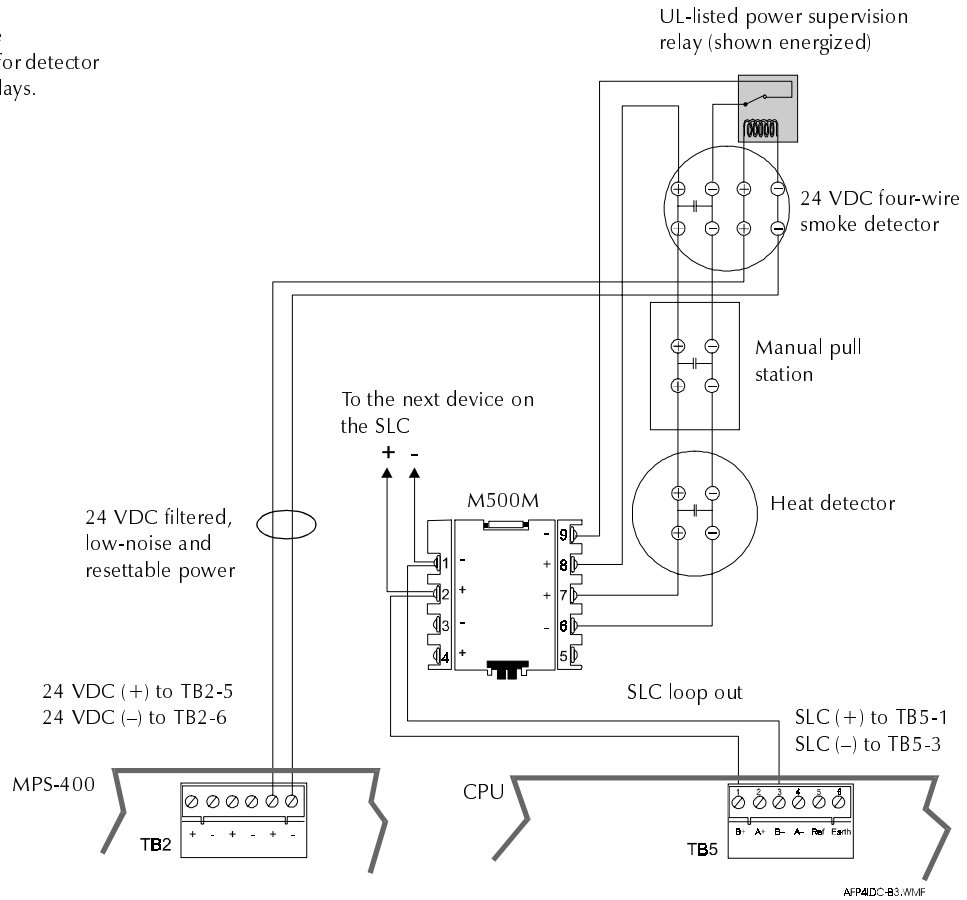

Figure 2-70 Typical Style D (Class A) IDC Wiring with M500Ms

Wiring a NFPA Style D IDC with M502M Modules

Figure 2-71 shows typical wiring for a Style D IDC using an M502M module. For electrical specifications for a Style D IDC, see Table 2-21.

The Maximum	is...
Circuit resistance	25 ohms
Alarm current	90 mA
Detector standby current	2.4 mA

Table 2-21 Style D IDC Electrical Specifications

Note: For more information, refer to the M502M Installation Instructions, Document M500-03-00. For compatible devices, refer to the Device Compatibility Document.

Figure 2-71 shows typical M502M wiring for a supervised and power-limited NFPA Style D (Class A) IDC:

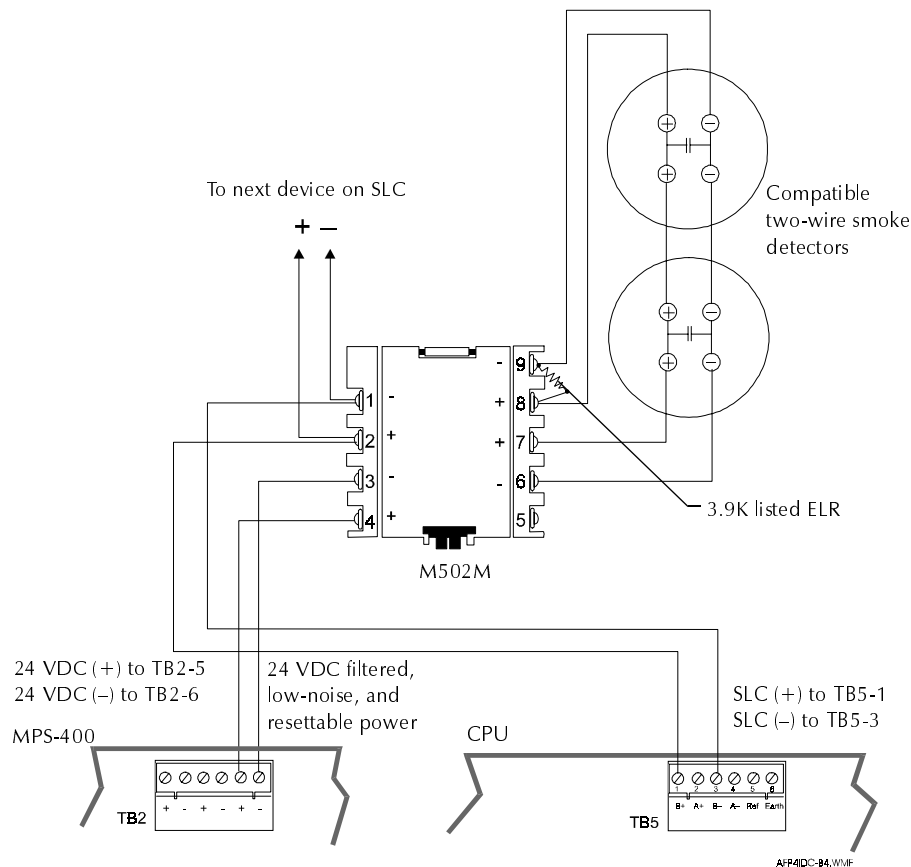

Figure 2-71 Typical Style D (Class A) IDC Wiring with M502Ms

Wiring a Notification Appliance Circuit (NAC) or Control Circuit

M500CH Module Overview

The M500CH Control Module is an addressable module that supervises and switches power to a Notification Appliance Circuit (NAC). You can use M500CHs for one of the following applications:

- Switch 24 VDC NAC Power for NFPA Style Y (Class B) and NFPA Style Z (Class A) circuits; or
- Control a dry contact relay (when configured as a Form-C control relay).

Figure 2-72 shows an M500CH module configured for powering a 24 VDC NAC:

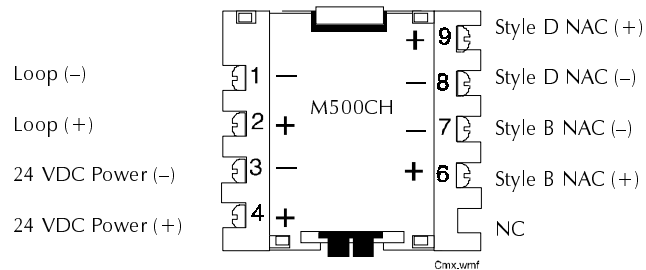

Figure 2-72 M500CH Control Module Configured for NAC Operation

Figure 2-73 shows an M500CH module wired to the CPU as a Form-C relay:

Note: Refer to the installation instruction sheet supplied with the M500CH module for additional information.

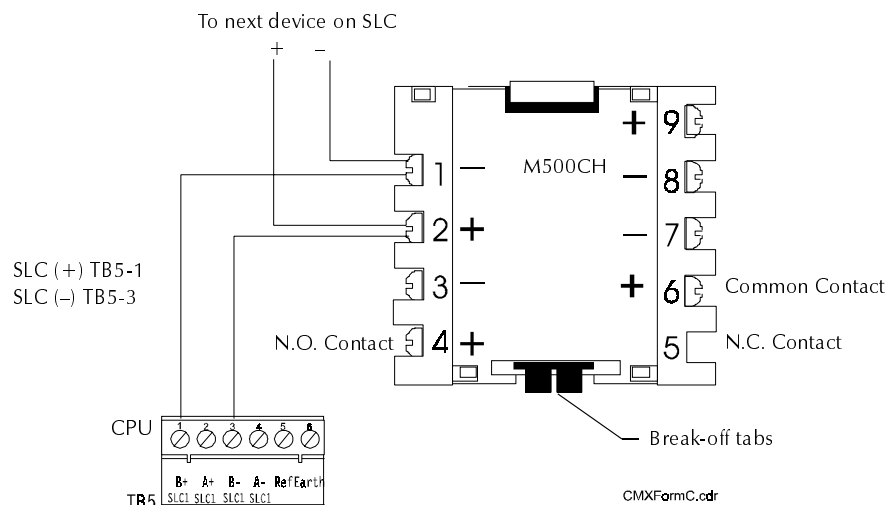

Figure 2-73 M500CH Control Module Configured as a Form-C Relay

Ratings for the dry contacts on an M500CH Form-C module are:

- Resistive: 2 A @ 30 VDC
- Inductive: 1 A @ 30 VDC (0.6pf)
Pilot Duty: 0.6 A @ 30 VDC (0.35pf)

Testing an M500CH Module

The M500CH module contains a magnetic test switch located on the front of the module. Activate the test switch by placing a magnet over the M500CH plastic cover. A test switch activation causes a short circuit indication on a Style B or Style D NAC.

Installing an M500CH as a Form-C Relay

Install an M500CH as a Form-C relay by following the instructions in Table 2-22:

Step	Action
1	<p>Configure an M500CH as a Form-C relay by using a needle-nose pliers to break off the two tabs (J1 and J2):</p>  <p style="text-align: right;">Break-off tabs (J1 and J2)</p>
	<p>Caution: On all M500CH modules used as Form-C relays—powering the system without breaking M500CH tabs J1 and J2 can cause serious damage.</p>
2	<p>Connect the SLC from the CPU to M500CH terminals 1 (-) and 2 (+) as shown in Figure 2-73.</p>
3	<p>Set the rotary switches on the M500CH to the required SLC address. (The M500CH takes one module address on the SLC.)</p>
4	<p>Wire the common and the normally-open or normally-closed contacts to the M500CH (Figure 2-73).</p>

Table 2-22 Installing an M500CH Module as a Form-C Relay

SLC Wiring with M500CH Modules

Note: "MPS-400/ICM-4 NAC Configurations" on page 2-25 contains detailed information on wiring an MPS-400 NAC.

This section contains instructions and wiring diagrams for wiring an M500CH as an NAC. Table 2-23 lists the applications for wiring an M500CH in an SLC:

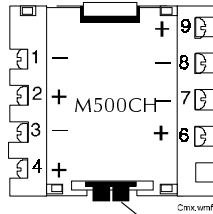
M500CH Function	Description	Refer to...
NFPA Style Y NAC (two-wire)	Polarized alarm notification appliances connected to a two-wire circuit.	Figure 2-74
NFPA Style Z NAC (four-wire)	Polarized alarm notification appliances connected to a four-wire circuit.	Figure 2-75
Notification Appliance Power	Method 1 – Notification appliance power to M500CH terminal 3 (common) and terminal 4 (+24 VDC).	Figure 2-76
	Method 2 – An alternate power arrangement where you power the M500CH (terminals 3 and 4) from one of the NACs on the MPS-400.	Figure 2-77

Table 2-23 Applications for SLC Wiring with M500CH Modules

Style Y NAC Circuits (Two-Wire)

Figure 2-74 shows a supervised and power-limited NFPA Style Y NAC using an M500CH module. This shows polarized alarm notification appliances connected to M500CH modules in a two-wire configuration. An M500CH module can control 2 A of resistive load (on electronic devices) or 1 A of inductive load (on mechanical bells and horns). If installing more than one M500CH NAC, install the power supervision relay on the 24 VDC power bus after the last M500CH.

Note: Refer to Device Compatibility Document for compatible notification appliances and relays.

- Do not T-tap or branch a Style Y circuit.
- Terminate the circuit across the last device using a 47K, 1/2-watt ELR (PN ELR-47K).
- Do not run wiring under any terminals. To maintain supervision, break the wire run.

Wiring Diagram and Instructions

Connect the NAC as follows:

1. Connect the SLC to M500CH terminals 1 (–) and 2 (+).
2. Connect 24 VDC power to MPS-400 TB2 (Figure 2-74).
3. Set the M500CH rotary switches to the required SLC address. (The M500CH takes one module address on the SLC.) For instructions on setting rotary switches, see Figure 2-67 on page 2-49.

Note: The circuit is supervised and power-limited. For detailed information on wiring an MPS-400 NAC, refer to "Wiring MPS-400 Output Circuits" on page 2-34.

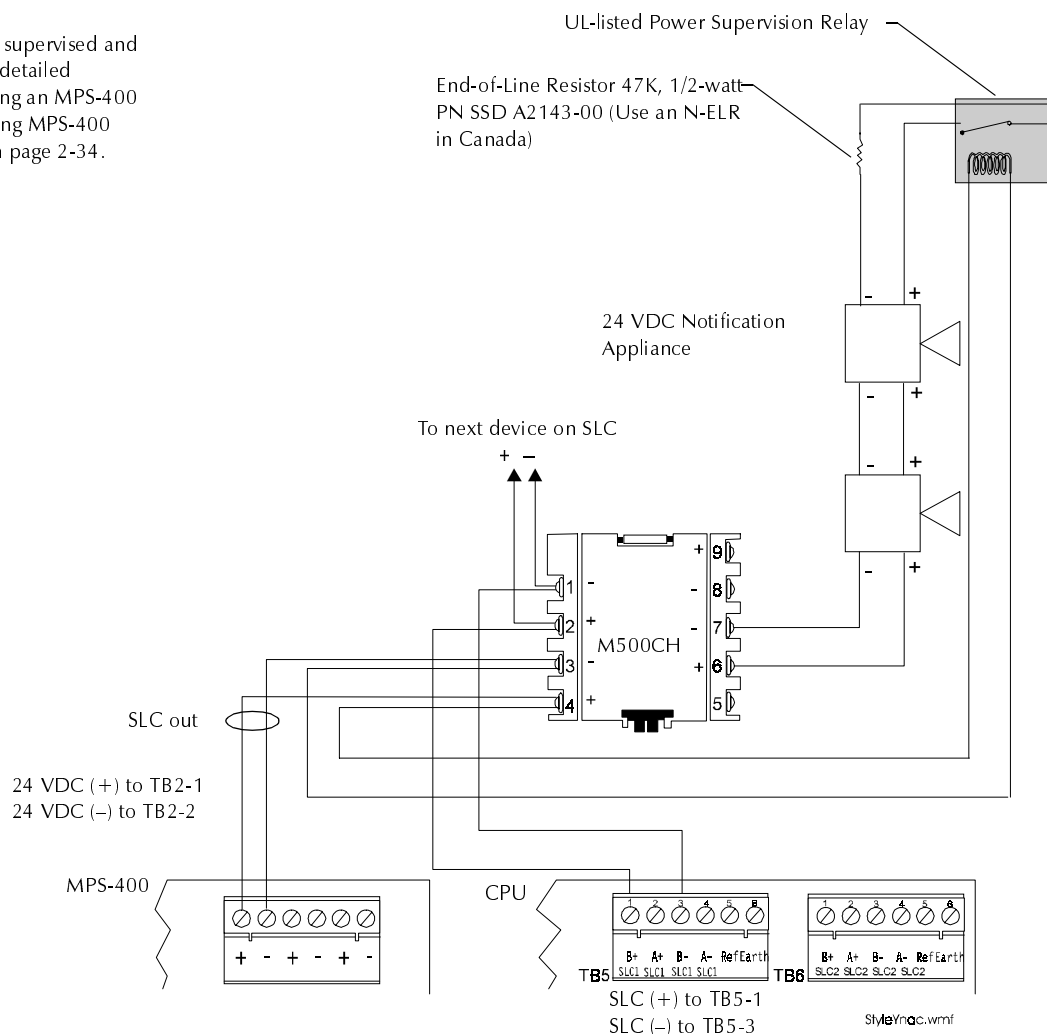

Figure 2-74 Typical Wiring for an NFPA Style Y NAC

Style Z NAC

Note: Refer to the Device Compatibility Document for compatible notification appliances.

Note: Do not loop wiring under any terminals. Break wire run to maintain supervision.

The NAC is supervised and power-limited.

Figure 2-75 shows an NFPA Style Z NAC with notification appliances connected to an M500CH module.

Connect the NAC as follows:

1. Connect the SLC to M500CH terminals 1 (-) and 2 (+).
2. Connect 24 VDC power from MPS-400 TB2 to M500CH terminals 3 and 4.
3. Set the M500CH rotary switches to the required loop address. (The M500CH takes one module address on the SLC.) For instructions on setting rotary switches, see Figure 2-67 on page 2-49.

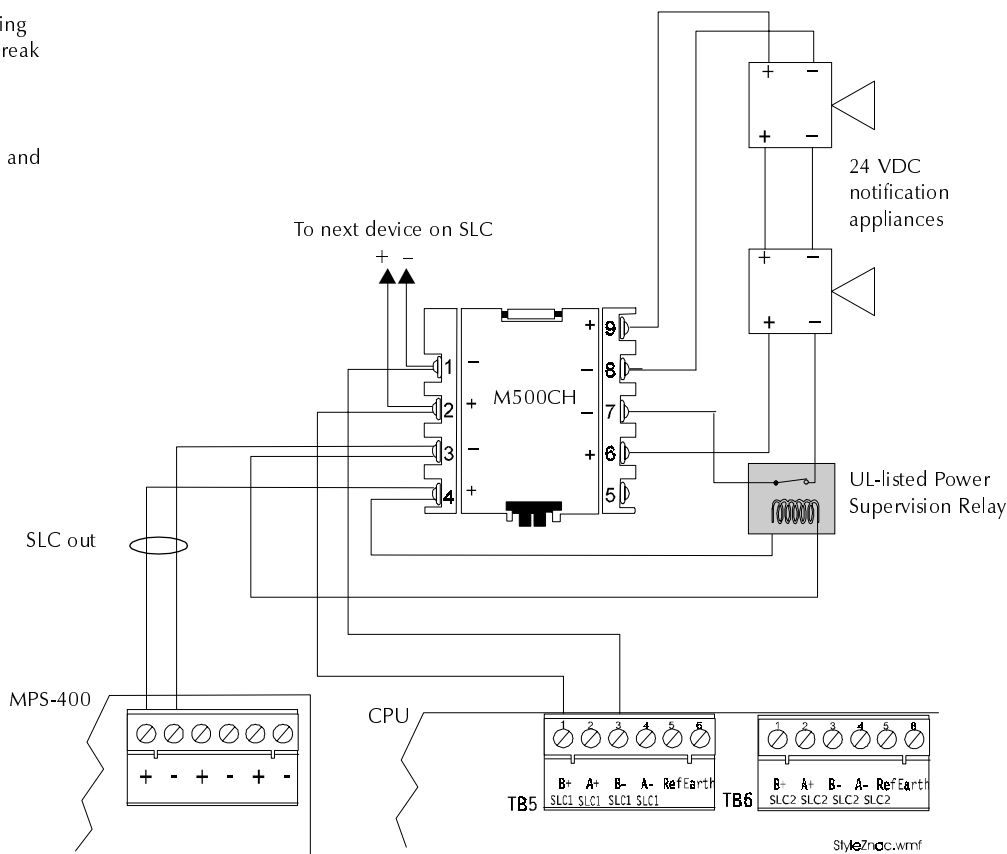

Figure 2-75 NFPA Style Z Notification Appliance Circuit

**Style Z NAC Circuits
(Method 2 – MPS-400
powers M500CH)**

Figure 2-77 shows a second method of powering an M500CH from an MPS-400 NAC. (See Figure 2-76 on page 2-58 for the first method.) The NAC is supervised and power-limited. When an MPS-400 NAC supplies power to M500CH modules:

- The M500CH module outputs are coded if the MPS-400 NAC is coded.
- Program the MPS-400 NAC for general alarm. (Refer to the Programming Manual for instructions.)

Note: Refer to the Device Compatibility Document for compatible notification appliances.

Connect the NAC as follows:

1. Connect the SLC to M500CH terminals 1 (–) and 2 (+).
2. Connect 24 VDC power from an MPS-400 NAC (TB7-TB10) to M500CH terminals 3 and 4.
3. Terminate the power feed to the M500CH module with a 2.2K ELR (PN R-2.2K) or make the power feed a return to MPS-400 NAC terminals 3 and 4 (Figure 2-77).
4. Set the M500CH rotary switches to the required SLC address. (The M500CH takes one module address on the SLC.) For instructions on setting rotary switches, see Figure 2-67 on page 2-49.

Note: Do not loop wiring under any terminals. Break wire run to maintain supervision. "MPS-400/ICM-4 NAC Configurations" on page 2-25 contains detailed information on wiring an MPS-400 NAC.

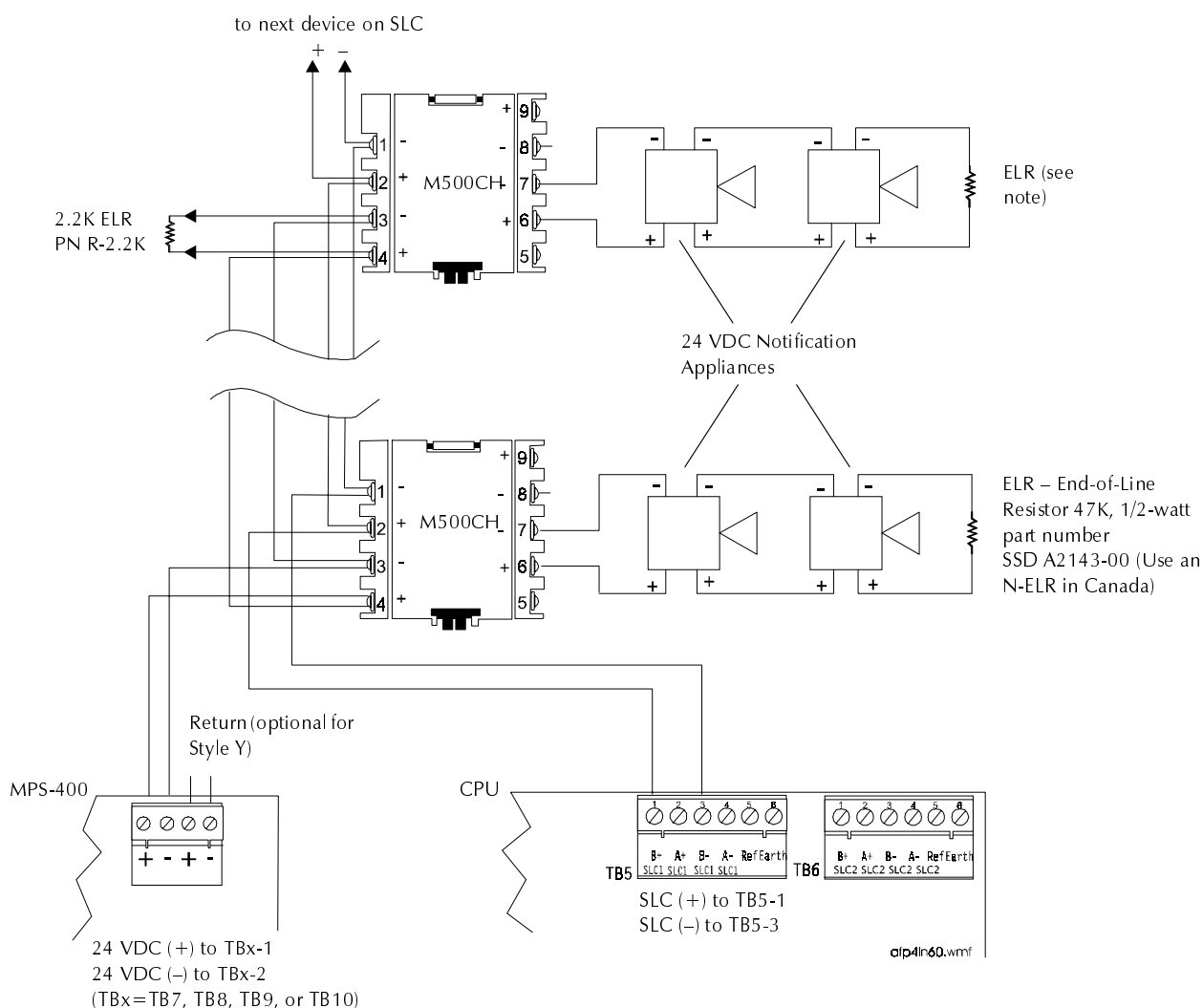

Figure 2-77 NFPA Style Z Notification Appliance Circuit (Method 2)

SLC Wiring with an Intelligent Detector

Overview for Wiring Intelligent Detectors

The B501B base provides the connection between the SLC and 2551, 2551TH, 1251, 2251, 5551R, and 3251 intelligent detectors.

1. Connect the communications loop to terminal 1 (–) and terminal 2 (+) on the detector mounting base.
2. If using an RA400Z Remote LED Annunciator: (a) connect the RA400Z positive terminal to B501B or B210LP terminal 3; and (b) connect the RA400Z negative terminal to B501B terminal 1 base.
3. Set the detector address on the head with a small, slotted screwdriver. Mark this address on the base and on the head.
4. Install the intelligent detector head.

Wiring a B501B Detector to an SLC Loop

Figure 2-78 shows typical wiring of a B501B detector base (wired to a RA400Z remote annunciator) connected to an SLC loop:

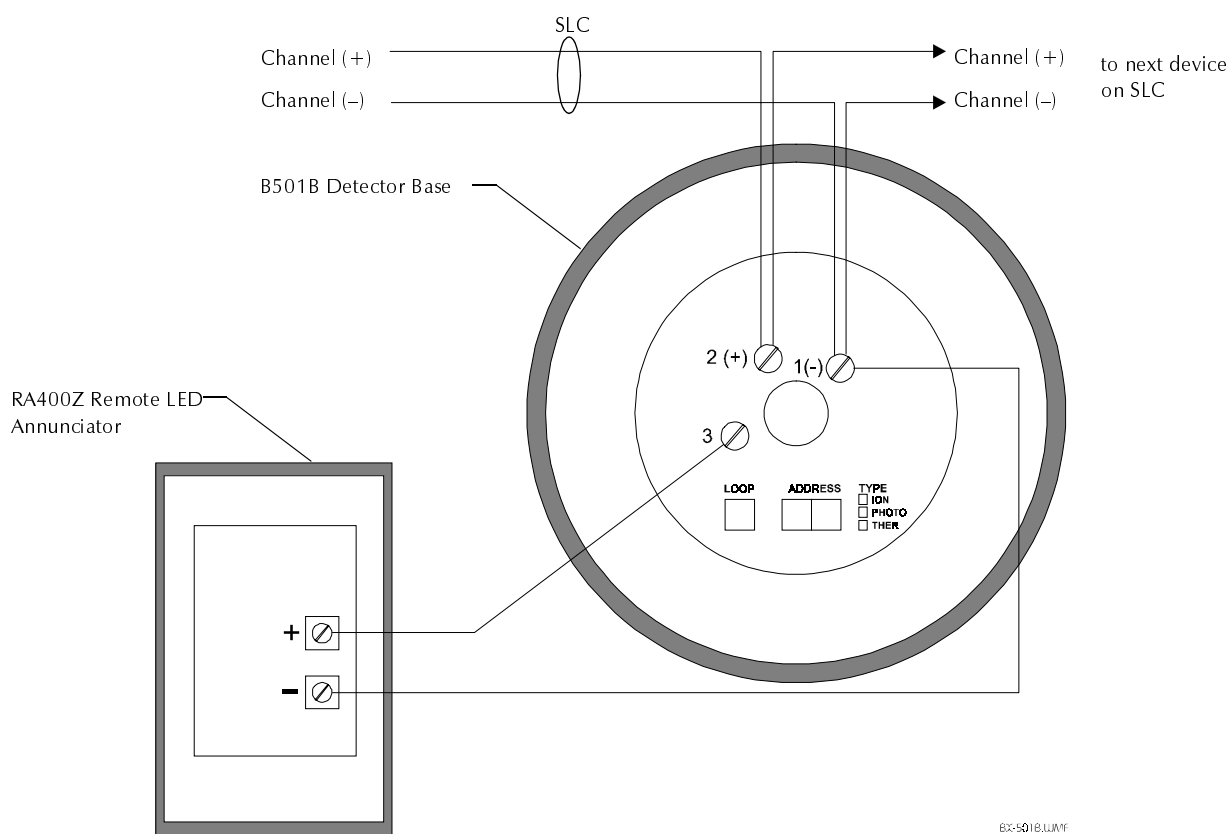

Figure 2-78 Typical Wiring of a B501B Detector to an SLC

SLC Wiring with an ADT-BGX-101L Addressable Manual Pull Station

ADT-BGX-101L Overview

The ADT-BGX-101L is an addressable manual pull station with a key-lock reset feature.

1. Connect the SLC to terminal screws (+) and (-).
2. Connect the ADT-BGX-101L to the CPU as listed in Table 2-24:

Connection	SLC 1	SLC 2
Loop Out	TB5-1 (+) TB5-3 (-)	TB6-1 (+) TB6-3 (-)
Loop Return	TB5-2 (+) TB5-4 (-)	TB6-2 (+) TB6-4 (-)

Table 2-24 ADT-BGX-101L SLC Connections

3. Set the SLC address of the ADT-BGX-101L as shown in Figure 2-79.

ADT-BGX-101L Wiring Connections

Figure 2-79 shows typical wiring for an ADT-BGX-101L (back view shown) and provides instructions for setting the SLC address:

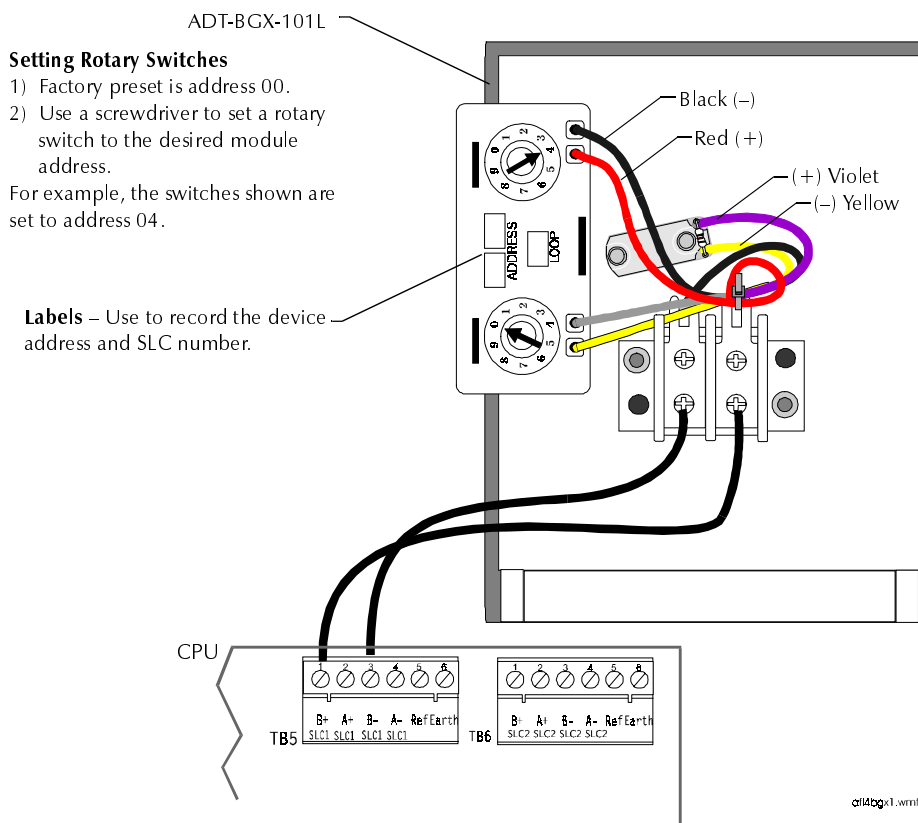

Figure 2-79 Typical SLC Wiring of an ADT-BGX-101L Pull Station

Notes

3. Testing the System

Acceptance Test

When finished with the original installation and all modifications, conduct a complete operational test on the entire installation to verify compliance with applicable NFPA standards. Testing should be conducted by a factory-trained fire alarm technician in the presence of a representative of the Authority Having Jurisdiction and the owner's representative. Follow procedures outlined in NFPA Standard 72-1993, Chapter 7, Inspection, Testing and Maintenance.

Periodic Testing and Service

Periodic testing and servicing of the control panel, all initiating and notification devices, and any other associated equipment is essential to ensure proper and reliable operation. Test and service the control panel according to the schedules and procedures outlined in the following documents:

- NFPA Standard 72-1993, Chapter 7, Inspection, Testing and Maintenance.
- Service manuals and instructions for the peripheral devices installed in your system. Correct any trouble condition or malfunction immediately.

Operational Checks

Between formal periodic testing and servicing intervals, the following operation checks should be performed monthly, or more frequently when required by the Authority Having Jurisdiction.

Note: The battery test requires fully charged batteries. If batteries are new or discharged due to a recent power outage, allow the batteries to charge for 48 hours before testing.

- Check that the green AC POWER LED lights.
- Check that all yellow LEDs are off.
- Press and hold the LAMP TEST switch. Verify that all LEDs and all LCD display segments work.
- Before proceeding: a) notify the fire department and the central alarm receiving station if transmitting alarm conditions; b) notify facility personnel of the test so that alarm sounding devices are disregarded during the test period; and c) when necessary, disable activation of alarm notification appliances and speakers to prevent their sounding.
- Activate an Initiating Device Circuit using an alarm initiating device and check that all active notification appliances function. Reset the alarm initiating device, the control panel, and any other associated equipment. In voice alarm applications, confirm that the proper tone(s) and/or messages sound during alarm conditions. Select the paging function and confirm that the message can be heard in the affected fire zones. Repeat the above step with each Initiating Device Circuit.
- On systems equipped with a fire fighters telephone circuit, make a call from a telephone circuit and confirm a ring tone. Answer the call and confirm communication with the incoming caller. End the call and repeat for each telephone circuit in the system.
- Remove AC power, activate an Initiating Device Circuit through an alarm initiating device, and check that active notification appliances sound, and alarm indicators illuminate. Measure the battery voltage with notification appliances active. Replace any battery with a terminal voltage less than 21.6 VDC and reapply AC Power.
- Return all circuits to their pre-test condition.
- Check that all yellow LEDs are off and the green AC POWER LED is on.
- Notify fire, central station and/or building personnel when you finish testing the system.

Test Modes

The control panel provides two test modes: Walk Test and Live Test. Both test modes modify the detection algorithms for faster detectors response time during a test mode, which reduces system test time.



Warning: Walk Test mode can deactivate fire protection. Make sure to do the following for a Walk Test:

- **Before doing a Walk Test, make sure to secure all protected buildings, and notify the building owner/operator, fire department, and other persons that testing is in progress.**
- **When finished doing a Walk Test, exit Walk Test mode immediately and notify the building owner/operator, fire department, and other persons that testing is complete and is restored to normal operation.**

Walk Test Mode

To enter Walk Test mode, follow these steps:

1. Press **Enter** and the control panel displays the Program Entry screen:

```
1=PROGRAMMING      2=READ STATUS ENTRY
(ESCAPE TO ABORT)
```

Figure 3-1 Program Entry Screen

2. Press **1** and the control panel displays the Enter Password screen:

```
ENTER PROG OR STAT PASSWORD, THEN ENTER.
(ESCAPE TO ABORT)
```

Figure 3-2 Enter Password Screen

3. Enter the Status Change password to display the Status Change screen:

```
STATUS CHANGE PRESS:1=DISABL 2=SENSITIV
3=CLR VER 4=CLR HIST 5=TIME 6=WALK TEST
```

Figure 3-3 Status Change Screen

4. Press **6** to display the Walk Test screen (Figure 3-4):

```
WALK TEST          PRESS ENTER TO START
ESCAPE TO ABORT
```

Figure 3-4 Walk Test Screen

In Walk Test mode, the control panel operates as follows:

- The System Trouble LED lights.
- The System Trouble relay (MPS-400, TB5) activates.
- The detection algorithms are modified to allow detectors to respond faster.
- The System Alarm relay (MPS-400, TB3) is disabled.
- Each new alarm activates its mapped outputs, that are programmed for Walk Test, for approximately 4 seconds.

Note: Releasing outputs cannot be programmed for Walk Test.

- Each test is saved and stored in the history file and sent to the printer (if installed).
- When finished with a Walk Test, press **Esc** to exit Walk Test mode and return the control panel to normal operation.

Live Test Mode

To enter Live Test Mode, follow these steps:

1. Press **Enter** and the control panel displays the Program Entry screen:



```
1=PROGRAMMING      2=READ STATUS ENTRY
(ESCAPE TO ABORT)
```

Figure 3-5 Program Entry Screen

2. Press **1** and the control panel displays the Enter Password screen:

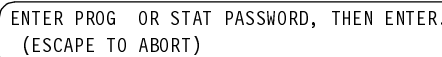

```
ENTER PROG OR STAT PASSWORD, THEN ENTER.
(ESCAPE TO ABORT)
```

Figure 3-6 Enter Password Screen

3. Enter the Live Test password "**LTEST**" to display the Live Test screen:

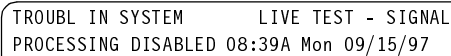

```
TROUBL IN SYSTEM      LIVE TEST - SIGNAL
PROCESSING DISABLED 08:39A Mon 09/15/97
```

Figure 3-7 Live Test Screen

In Live Test mode, the control panel operates normally except for the following:

- The panel sounder pulses unless silenced.
- The System Trouble LED lights.
- The System Trouble relay (MPS-400, TB5) activates.
- The detection algorithms are modified to allow detectors to respond faster.
- The releasing outputs are disabled.

When finished with a Live Test, press the **Esc** twice to exit Live Test and return the control panel to normal operation.

Battery Checks and Maintenance

Maintenance-free sealed lead-acid batteries used in the system do not require the addition of water or electrolyte. These batteries are charged and maintained in a fully charged state by the main power supply's float charger during normal system operation. A discharged battery typically charges at 1.5 A and reaches the float voltage of 27.6 VDC within 48 hours.

Follow the local AHJ and manufacturer recommendations for battery replacement intervals. Minimal replacement battery capacity appears on the control panel marking label. Immediately replace a leaking or damaged battery. You can get replacement batteries from the manufacturer.

Warning: Batteries contain Sulfuric Acid which can cause severe burns to the skin and eyes and damage to fabrics.



- **If a battery leaks and contact is made with the Sulfuric Acid, immediately flush skin and/or eyes with water for at least 15 minutes. Water and household baking soda provides a good neutralizing solution for Sulfuric Acid.**
- **If Sulfuric Acid gets into eyes, seek immediate medical attention.**
- **Ensure proper handling of the battery to prevent short-circuits.**
- **Take care to avoid accidental shorting of the leads from uninsulated work benches, tools, bracelets, rings, and coins.**

Shorting the battery leads can damage the battery, equipment, and could cause injury to personnel.

4. Voice Alarm System

Section Overview

This section contains instructions for installing and wiring modules that can be used in a Unimode 400 voice alarm system. Table 4-1 contains the topics covered in Section 4.

Section	Covers the following topics...	Page
Installing an AMG	Mounting an AMG/ATG Assembly Wiring an AMG Setting AMG switches AMG tone and Message selections AMG/ATG terminals and connections	4-2
Installing a Fire Fighter's Telephone (FFT-7 and FFT-7S)	Mounting an FFT-7/FFT-7S terminal and connections	4-8
Installing Audio Amplifiers (AA-30/AA-100/AA-120)	Mounting an AA-30, AA-100, and AA-120 Terminal Connections for AA-30, AA-100, AA-120 Installing an AA as a Backup Amplifier	4-10
Voice Alarm Modules	Connecting VCM-4 Speaker Circuits Connecting VCM-4 Telephone Circuits Setting a VCM-4 to Speaker or Telephone Mode Connecting DCM-4 Speaker Circuits	4-15
Voice System Configurations	Internal Power Connections CPU EIA-485 Connections Wiring Audio Components without a Backup Amplifier Wiring Audio Components with a Backup Amplifier CPU Trouble Bus Connections	4-20
Wiring Speaker Circuits	30 Watts – 4- and 8-speaker Configuration 120 Watts – 4- and 8-speaker Configuration 90 Watts – 8-speaker Configuration 240 Watts – 8-speaker Configuration 180 Watts – 8-speaker Configuration 30 Watts – Dual-Channel Configuration 120 Watts – Dual-Channel Configuration	4-26
Voice Message Options (VROM and VRAM)	Overview of VROM and VRAM Installing VROM and VRAM	4-35
ACT-1 Audio Coupling Transformer	Overview Isolating Power Supplies Installing an ACT-1 Message	4-36

Table 4-1 Voice System Topics

Installing an AMG

Figure 4-1 contains instructions for installing an AMG module into a CHS-4L chassis:

Step	Action
1	<p>Put a standoff on the first and fourth studs from the top-left corner of the CHS-4L chassis.</p> 
2	<p>Angle the bottom edge of the module into the bottom slot of the CHS-4L.</p> 
3	<p>Secure the module to the CHS-4L with the captive screws.</p> 

Figure 4-1 Installing an AMG Module

Figure 4-2 shows the AMG-1 terminals:

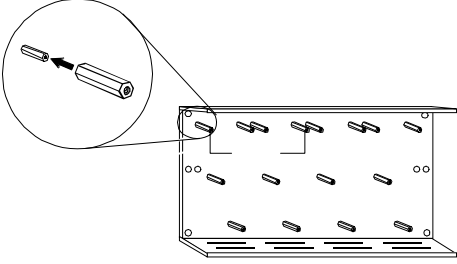
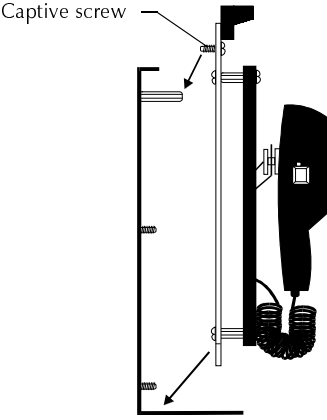
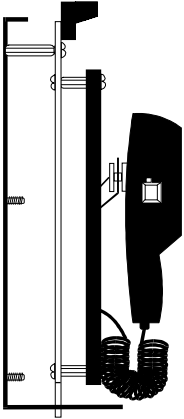
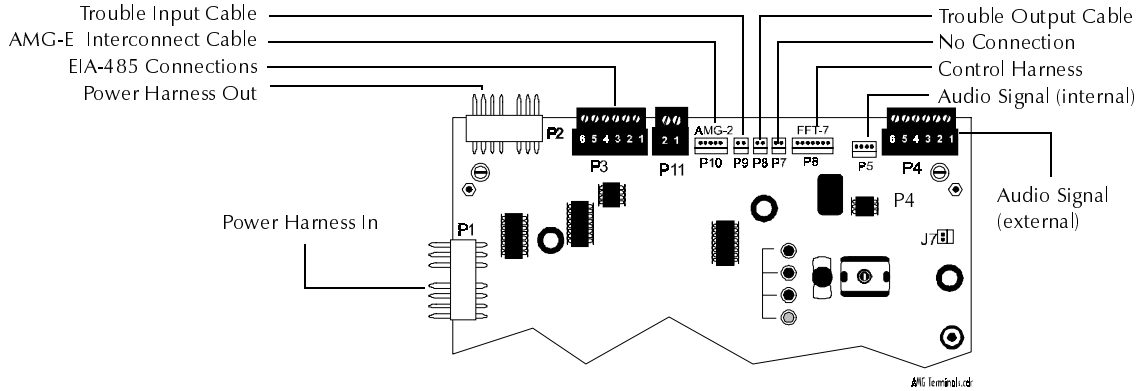

Figure 4-2 AMG-1 Terminals

Table 4-2 contains descriptions of the AMG-1 terminals:

Input/Output	Plug	Used to...
Trouble Input Cable (normally open trouble contacts) PN 75098	P9	Transmit trouble signals to another system device. (Connect the other end to the Trouble Input of the other device in the system or to J4 (Aux Trouble Input) on the MPS-400.)
Trouble Output Cable (normally open trouble contacts) PN 71033	P8	Transmit trouble signals to another device in the system.
Power Harness Out PN 75099	P2	Connect to another power supply in a power supply chain.
Power Harness In PN 75396 or 75100	P1	Provides power for the AMG-1 from the Main Power Supply. (Connect the other end to J1 on the MPS-400.)
AMG-1 Interconnect Cable PN 75136	P10	Connect from the Trouble Output contacts on another AMG-1. A closure signals the AMG-1 that the connected device is in trouble.
EIA-485 Connections	P3	Lets the control panel communicate with the AMG-1 through the ACS mode EIA-485 port.
No connection	P7	N/A
Audio Signal Connections PN 75110	P5	Allow harnessing the audio signal from the AMG-1 to Audio Amplifiers in the same cabinet via P5, or wired to amplifiers in remote cabinets through P4.
Control Harness PN 75097	P6	Connect to P4 on a Fire Fighter's Telephone (FFT-7) or cable from the Audio Voice Link (AVL-1).
Low Level Audio PN 75100	P4	Allows wiring of the AMG audio output to an Audio Amplifier as follows:
	Connector	From AMG... To AA...
	Low Level Audio Output to first amplifier	P4-5 P3-5 P4-4 P3-4
	Low Level Audio Output Return to last amplifier (optional)	P4-2 P3-2 P4-1 P3-1

Table 4-2 AMG-1 Terminal Connections

Configuring the AMG

An AMG appears as an annunciator to the control panel and operates on address 01. Installing an AMG requires programming the control panel and setting the AMG-1 DIP switch. Table 4-3 contains AMG programming and switch settings:

For	Set
Single-channel applications	AMG-1 RECEIVE ONLY switch to Off.
Dual-channel applications	1) AMG-1 Evacuation channel RECEIVE ONLY switch to Off; and 2) AMG-E Alert channel RECEIVE ONLY switch to On.
Optional four-wire return	AMG-1 DIP switch to On.

Note: You can set an AMG to receive only (DIP 3) but you cannot use the ALL-CALL switch.

Table 4-3 AMG Programming and Switch Settings

Figure 4-3 shows typical wiring for an AMG-1 configured for four-wire operation:

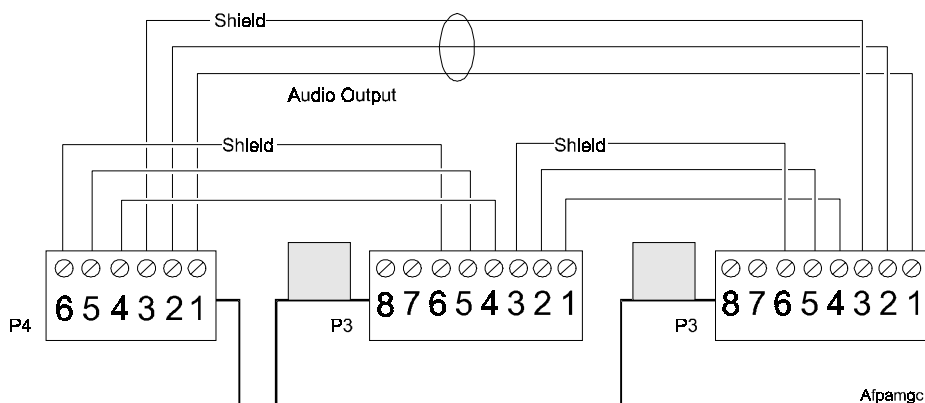
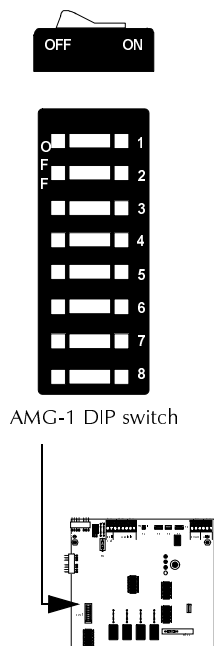

Figure 4-3 Typical Wiring for an AMG-1 Four-Wire Configuration

Table 4-4 contains descriptions of the pins on the AMG-1 DIP switch:



Pin	Function	Setting
1	Four-wire audio supervision	On Off
2	Tone/Message Select	Table 4-5 – Off Table 4-6 – On
3	Receive Only	Refer to Installing an AMG.
4	VRAM A	Refer to Voice Message Options.
5	VRAM B	Refer to Voice Message Options.
6	Message Select	Refer to Table 4-5 and Table 4-6.
7	Message Select	
8	Message Select	

Table 4-4 AMG-1 DIP Switch

AMG-1 and AMG-E Tone/Message Selections (SW2=Off)

Table 4-5 lists the tone and message selections available when DIP switch 2 (Tone/Message Switch) is Off:

SW2 Rocker Switches			System Status	NAC 1 (B01) Condition	Audio Tone or Message
S6	S7	S8			
X	X	X	No Alarm	Off	Standby
Off	Off	Off	No Alarm	On	1000 Hz 1/2 sec on, 1/2 sec off
Off	Off	Off	Alarm	X	Slow whoop
Off	Off	On	No Alarm	On	Horn
Off	Off	On	Alarm	X	120 ppm (March Time)
Off	On	Off	No Alarm	On	Horn
Off	On	Off	Alarm	X	Yelp
Off	On	On	No Alarm	On	Yelp
Off	On	On	Alarm	X	Wail
On	Off	Off	No Alarm	On	3 slow whoops, VRAM-B plays
On	Off	Off	Alarm	X	3 slow whoops, VRAM-A plays
On	Off	On	No Alarm	On	VROM-B message plays
On	Off	On	Alarm	X	VROM-A message plays
On	On	Off	No Alarm	On	20 ppm (Two-Stage)
On	On	Off	Alarm	X	VROM-A and VROM-B play
On	On	On	No Alarm	On	Horn
On	On	On	Alarm	X	NFPA Uniform Code 3 Temporal pattern fast whoop
<p>X = Indicates that switch or control point can be On or Off.</p> <ol style="list-style-type: none"> MPS-400 Notification Appliance Circuit 1 can be manually selected with an ADT-ACM-16AT to produce a desired tone or can be activated through Control-by-Event by a non-alarm input. If selecting a VROM or VRAM, and a VROM or VRAM chip is not installed, a trouble indication appears at the AMG-1 when the message is due to begin and the AMG-1 generates the 1 kHz default tone. 					

Table 4-5 AMG Tone/Message Selections (SW2=Off)

AMG-1 and AMG-E Tone/Message Selections (SW2=On)

Table 4-6 lists the tone and message selections available when DIP switch 2 (Tone/Message Switch) is On:

AMG-1 SW2 Rocker Switches			System Status	NAC 1 (B01) Condition	Audio Tone or Message
S6	S7	S8			
X	X	X	No Alarm	Off	Standby
Off	Off	Off	No Alarm	On	Horn
Off	Off	Off	Alarm	Off	1000 Hz 1/2 sec on, 1/2 sec off for 5 min then slow whoop
Off	Off	On	No Alarm	On	Horn
Off	Off	On	Alarm	Off	20 ppm for 5 min., then 120 ppm
Off	Off	On	Alarm	On	120 ppm (March Time)
Off	On	Off	No Alarm	On	VROM-B
Off	On	Off	Alarm	Off	444, pause, VROM-A
Off	On	Off	Alarm	On	Boston Code
Off	On	On	No Alarm	On	VROM-B
Off	On	On	Alarm	Off	Fast whoop
Off	On	On	Alarm	On	3 fast whoops, pause, VROM-A
On	Off	Off	No Alarm	On	Beep
On	Off	Off	Alarm	Off	Fast whoop
On	Off	Off	Alarm	On	3 fast whoops, pause, VROM-A and VROM-B
On	Off	On	No Alarm	On	Beep
On	Off	On	Alarm	Off	3 slow whoops, pause, VROM-A
On	Off	On	Alarm	On	3 slow whoops, pause, VROM-A and VROM-B
On	On	Off	No Alarm	On	Wail
On	On	Off	Alarm	Off	3 hi-low tones, pause, VROM-A
On	On	Off	Alarm	On	3 hi-low, pause, VROM-A and VROM-B
On	On	On	No Alarm	On	Hi-low
On	On	On	Alarm	Off	20 ppm (Two-Stage)
On	On	On	Alarm	On	3 Slow whoops, pause, VROM-A
<p>“X” = Indicates that Switch or Control Point can be “On” or “Off.”</p> <ol style="list-style-type: none"> MPS-400 Notification Appliance Circuit 1 can be manually selected with an ADT-ACM-16AT to produce a desired tone or can be activated through Control-by-Event by a non-alarm input. If selecting a VROM or VRAM that is not installed, a trouble will be generated at the AMG-1 and the AMG-1 generates the 1 kHz default tone. Boston Code (order VROM 9, which must be installed in VROM-B position) – 900 Hz alert tone pulsed to produce one round of code 4 at approximately one second intervals, followed by female voice message: <p><i>“Attention please. The signal tone you have just heard indicates a report of an emergency in this building. If your floor evacuation signal sounds after this message, walk to the nearest stairway and leave the floor. While the report is being verified, occupants on other floors should await further instructions.”</i></p> <p>This message repeats. The evacuation signal is a slow-whoop tone—an ascending tone starting at approximately 600 Hz and ending at approximately 1100 Hz—with a duration of approximately 3-1/2 seconds and an interruption between tones of approximately 1/2 second.</p> 					

Table 4-6 AMG Tone/Message Selections (SW2=On)

ATG-2 Terminal Connections

Figure 4-4 shows ATG-2 terminal connections:

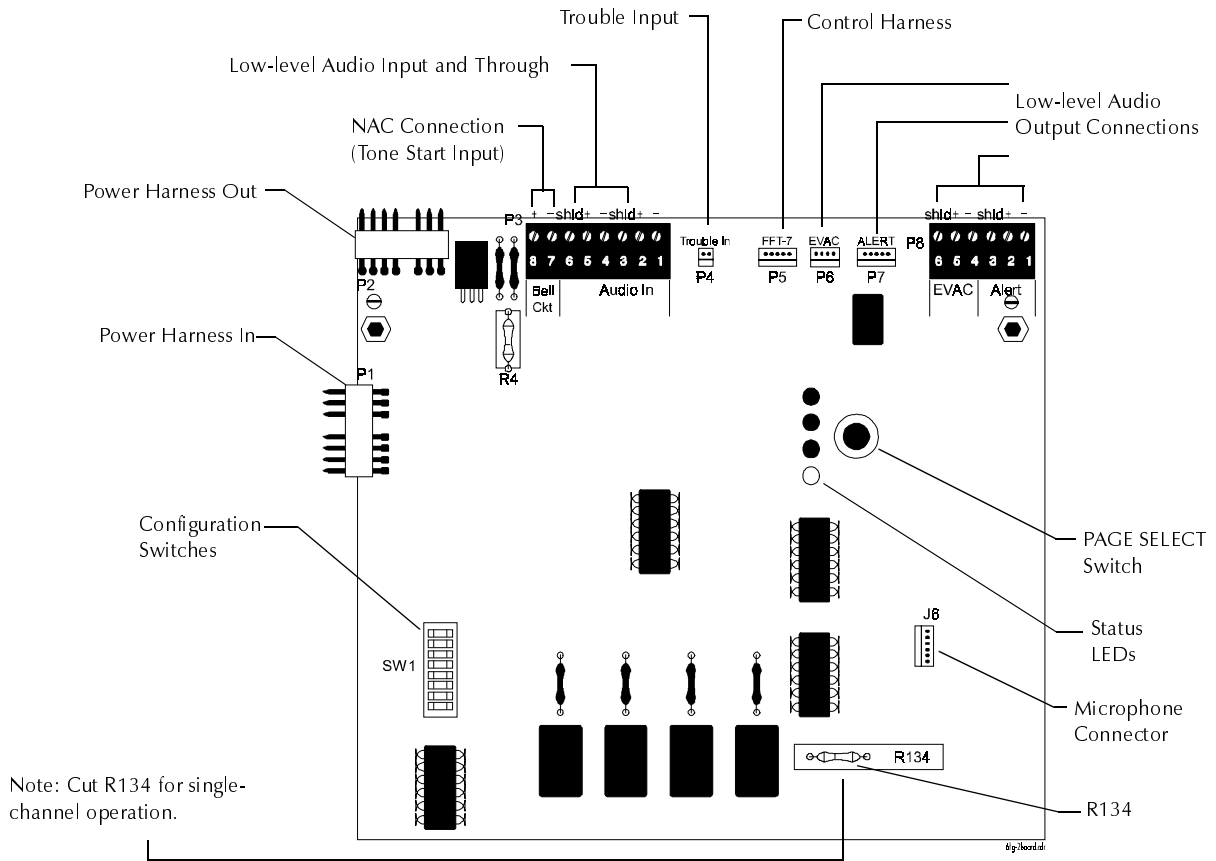

Figure 4-4 ATG-2 Terminal Connections

Table 4-7 lists descriptions for each of the ATG-2 connections:

Input/Output	Connections	Used for
Trouble Input	P4	Connecting trouble output contacts from an audio amplifier. A closure signals the ATG-2 when a device is in trouble. The trouble signal is relayed through the Notification Appliance Circuit connection.
Low Level Audio Input and Through	P3-1 to P3-6	When using the ATG-2 for remote paging, the low level audio output from the main ATG-2 or AMG is passed through the remote ATG-2, then passed on to the audio amplifiers.
Notification Appliance Circuit	P3-7 P3-8	Connecting 24 VDC regulated power if using Notification Appliance Circuits.
Power Harness In	P1	Connecting to the MPS-400 (J1) for providing power to the ATG-2.
Control Harness	P5	Connecting to P4 on a Fire Fighter's Telephone (if installed).
Low Level Audio Output Connections	P5 - FFT7 P6 - EVAC P7 - ALERT	Harnessing the ATG-2 audio signal to audio amplifiers in the same cabinet through P6 or P7; or wired to the audio amplifiers in other cabinets through P8.
Power Harness Out	P2	Connecting to another power supply in the power supply chain.

Table 4-7 Descriptions of ATG-2 Connections

Installing a Fire Fighter's Telephone (FFT-7 and FFT-7S)

Overview

The FFT-7 and the FFT-7S modules mount on designated studs on the CHS-4L chassis. The module installation kit includes standoffs to secure the module to the studs on the CHS-4L.

Mounting an FFT-7/FFT-7S

To mount an FFT-7 or FFT-7S, follow these steps:

1. Install standoffs for an FFT-7 or FFT-7S on the CHS-4L chassis mounting studs as shown in Figure 4-5:

FFT-7S – Put a standoff on the first, second, third, sixth, seventh, and eighth studs from the left corner of the CHS-4L

FFT-7 – Put a standoff on the fifth and eighth studs from the left corner of the CHS-4L chassis.

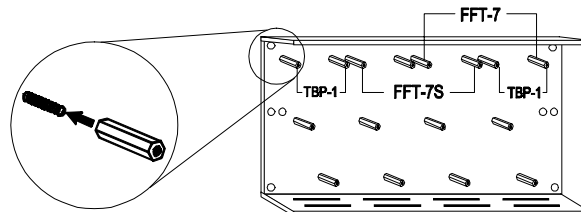

Figure 4-5 Installing Standoffs for an FFT-7/FFT-7S

2. Angle the bottom of the FFT-7/FFT-7S module into the bottom slot of the CHS-4L chassis and secure the module as shown in Figure 4-6:

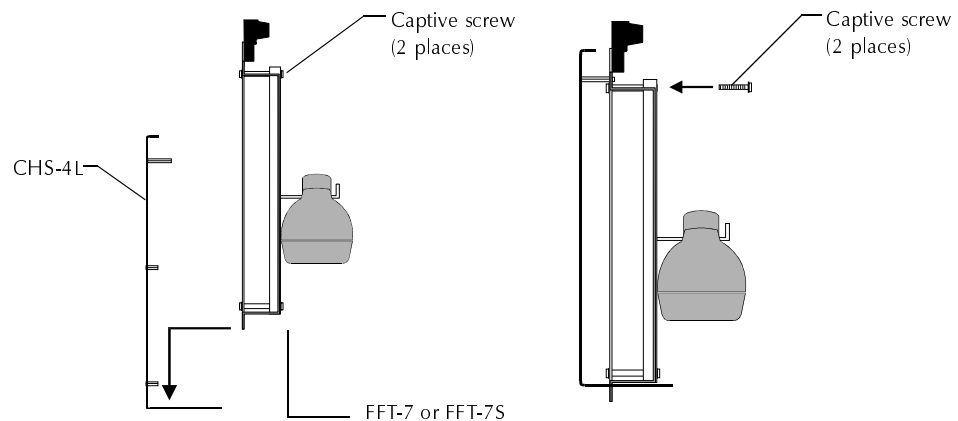

Figure 4-6 Mounting the FFT-7/FFT-7S to a CHS-4L

3. Mount TBP-1 dress panels on the FFT-7S as shown in Figure 4-7:

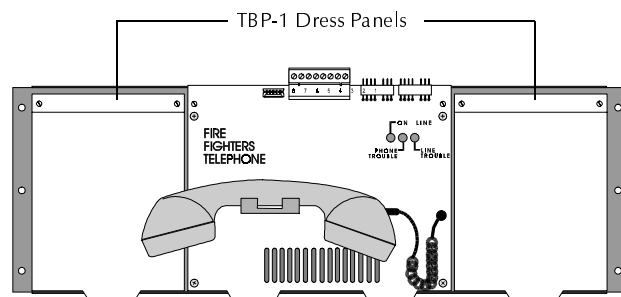

Figure 4-7 FFT-7S with Dress Panels

Connecting an FFT-7/FFT-7S

Figure 4-8 shows FFT-7/FFT-7S terminals and connections to other devices in the system. Follow the instructions in Table 4-8 to connect an FFT-7 or FFT-7S to a Unimode 400 system:

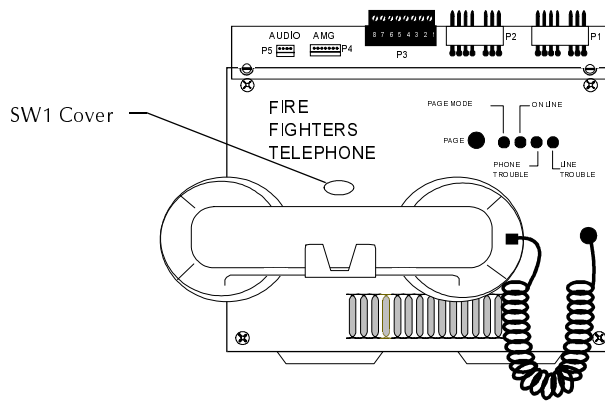

Figure 4-8 FFT-7/FFT-7S Terminals

Component	Function	Use to		
P1	Plug for power harness out (75099)	Connect a harness to another device in the chain.		
P2	Plug for power harness in (75099)	Connect a harness between FFT-7 and MPS-400 to power the FFT-7 from the MPS-400.		
P3	Telephone signal loop	Make connections to a telephone circuit. P3 pin assignments are:		
		Pin	Connection	Instructions
		1	no connection	N/A
		2	Style Z return (-)	Connect to J6 on last
		3	Style Z return (+)	VCM-4 on circuit.
		4	Shield	N/A
		5	Telephone output (-)	Connect to J5 on first
		6	Telephone output (+)	VCM-4.
7	no connection	N/A		
8	no connection	N/A		
P4	FFT-7/AMG control harness (75097)	Connect to plug P6 on the AMG or plug P5 on the ATG-2.		
P5	No connection	N/A		
SW1	Two-wire/four-wire selector switch	Set the control panel for four-wire operation: 1) Remove the switch cover. 2) Set SW1 for four-wire operation.		

Table 4-8 FFT-7/FFT-7S Terminals and Connections

Installing Audio Amplifiers (AA-30/AA-100/AA-120)

Installing an AA-30

Overview

The AA-30 mounts in a CHS-4L chassis, which can hold two AA-30s placed side by side. In addition to mounting, do the following:

1. Connect a primary (AC) and a secondary (24 VDC battery) power source to each AA-30.
2. Provide an external device (such as an MPS-400) for charging the batteries.

Mounting an AA-30

Mount an AA-30 into a CHS-4L chassis by following these steps.

Step	Action
1	<p>Put the bottom end of the AA-30 assembly into the slot in the bottom of the CHS-4L chassis. Swing the assembly into the chassis.</p> 
2	<p>Secure the AA-30 to the chassis with the washers and retaining nuts.</p> 

Figure 4-9 Mounting an AA-30 into a CHS-4L Chassis

AA-30 Terminals and Connectors

Figure 4-10 and Figure 4-11 show terminal connections to an AA-30.

- The low-level audio input and high-level audio output P connectors are primarily for in-cabinet applications where the wiring to or from the AA-30 remains in the cabinet. For multiple-cabinet applications, hard-wire the system using terminal blocks P3 and P8.
- Cut resistors R8 and R9 when using high-level audio in four-wire mode.
- For information on the ACT-1, refer to “ACT-1 Audio Coupling Transformer” on page 4-36.

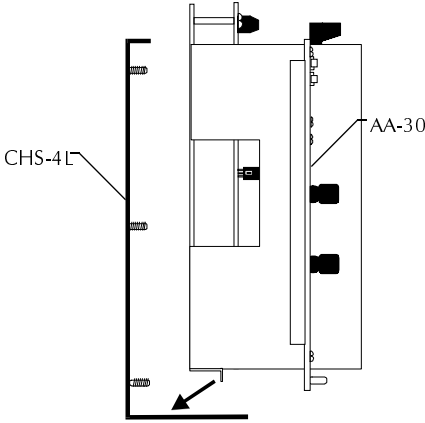
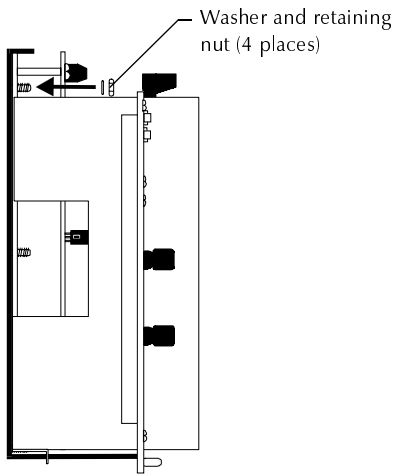
AA-30 Lower Board Connections Figure 4-10 shows terminal connections to an AA-30 lower board:

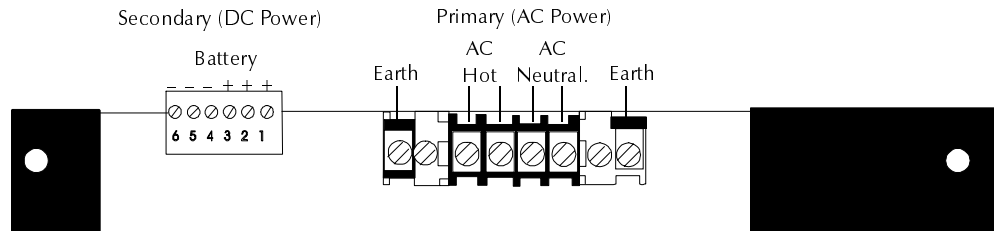

Figure 4-10 AA-30 Lower Board Connections (nonpower-limited)

AA-30 Upper Board Connections Figure 4-11 shows terminal connections to an AA-30 upper board:

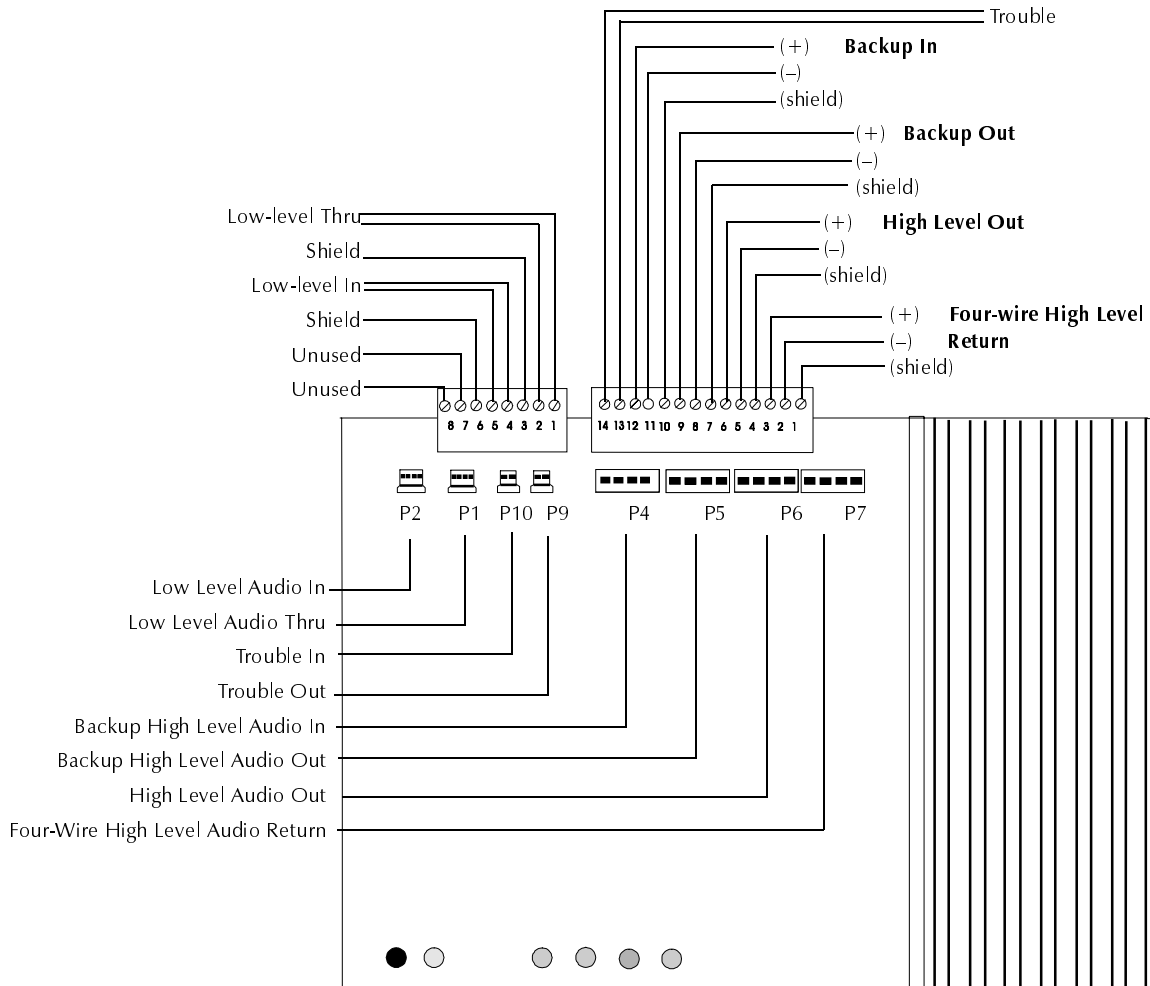

Figure 4-11 AA-30 Upper Board Connections (nonpower-limited)

Installing an AA-100/AA-120

Overview

The AA-100/AA-120 mounts directly to the cabinet backbox. In addition to mounting, do the following:

1. Connect primary (AC) and secondary (24 VDC battery) power source to each audio amplifier.
2. Provide an external device for charging the batteries (such as an MPS-400).

Mounting an AA-100/AA-120

AA-100/AA-120 audio amplifiers mount directly to the backbox. To do so, follow the steps in Table 4-9:

Step	Action
1	<p>Mount the AA-100/AA-120 onto the PEM studs on the cabinet backbox (in the same way as the CHS-4 and CHS-4L chassis) as shown in Figure 4-12:</p> 
2	<p>Install the two #8 nuts and lockwashers (Figure 4-12) onto the PEM studs and tighten until secure.</p>

Figure 4-12 Mounting an AA-100/AA-120

Table 4-9 Mounting an AA-100/AA-120

**AA-100/AA-120
Terminals and
Connectors**

Low-level audio input and high-level audio output connectors are primarily for in-cabinet applications where the wiring to or from the AA-100/AA-120 remains in the cabinet. For multiple-cabinet applications, use the terminals.

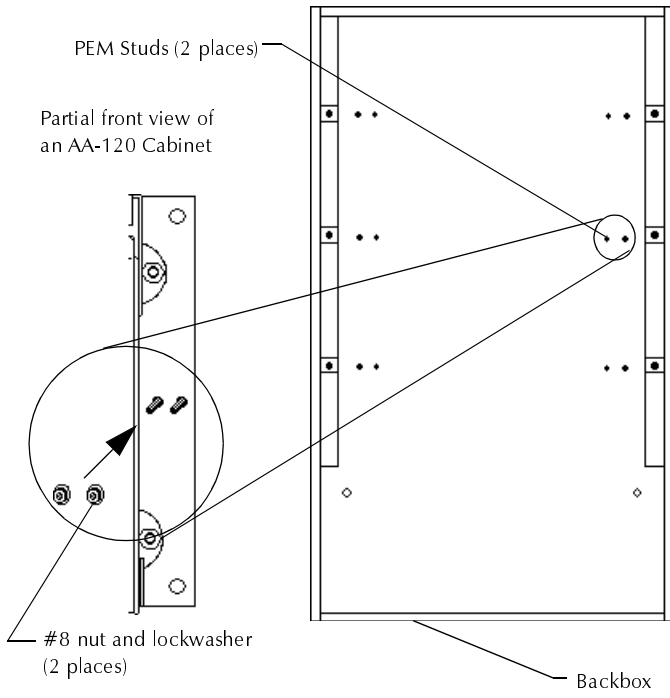
AA-100/AA-120 Lower Board Connections Figure 4-13 shows terminal connections to an AA-100/AA-120 lower board:

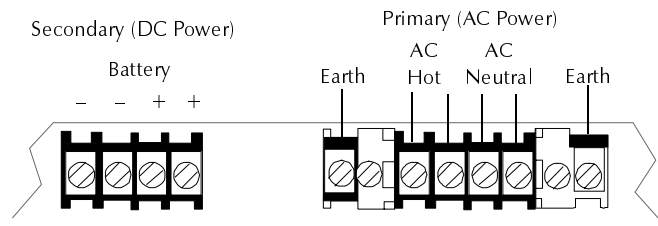

Figure 4-13 AA-100/AA-120 Lower Board Connections

AA-100/AA-120 Upper Board Connections Figure 4-14 shows terminal connections to an AA-100/AA-120 Upper Board:

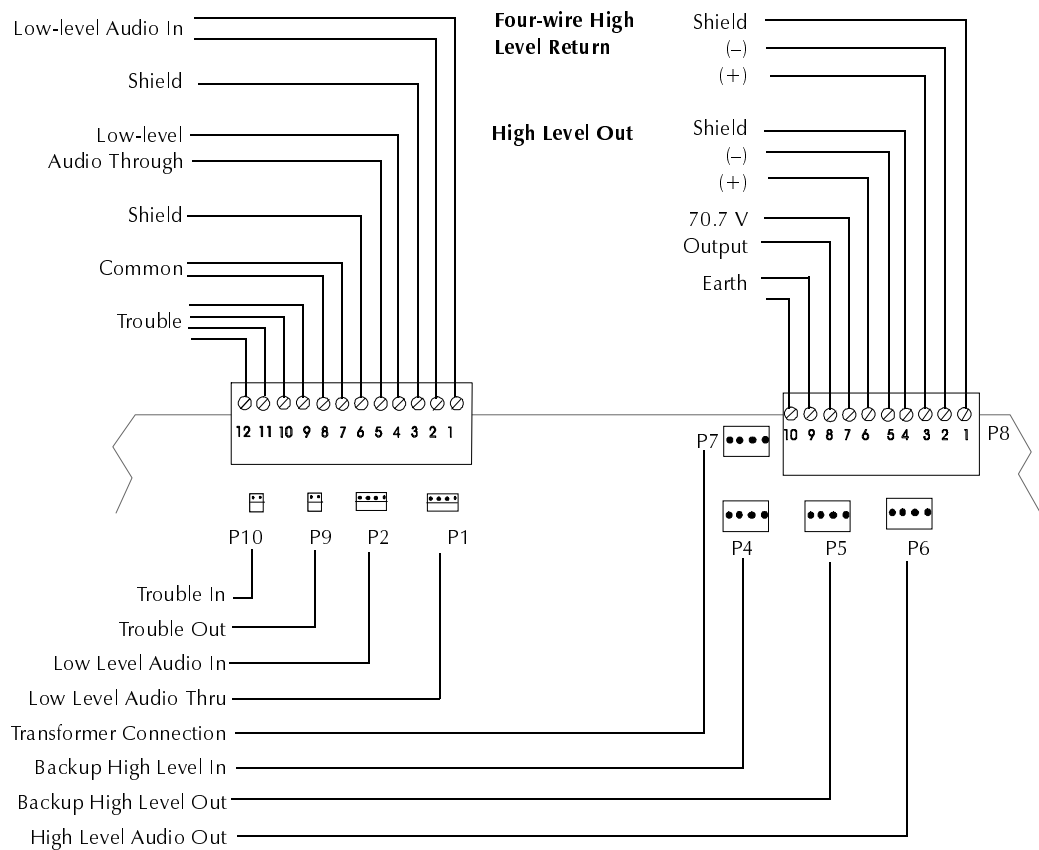

Figure 4-14 AA-100/AA-120 Upper Board Connections

Installing a Backup Amplifier

Overview

Use an AA-30, AA-100 or AA-120 Audio Amplifier to back up one or more amplifiers. If an amplifier fails, backup amplifier switching is automatic. To connect amplified audio output, do the following:

- Use P6 for connection to VCM-4/VCE-4; or
- Use P8 for connection to M500CH modules.

Typical Installation Drawing

Figure 4-15 shows a typical wiring configuration using an AA-120 as a backup amplifier:

Note: Cables must enter from top of the plug.

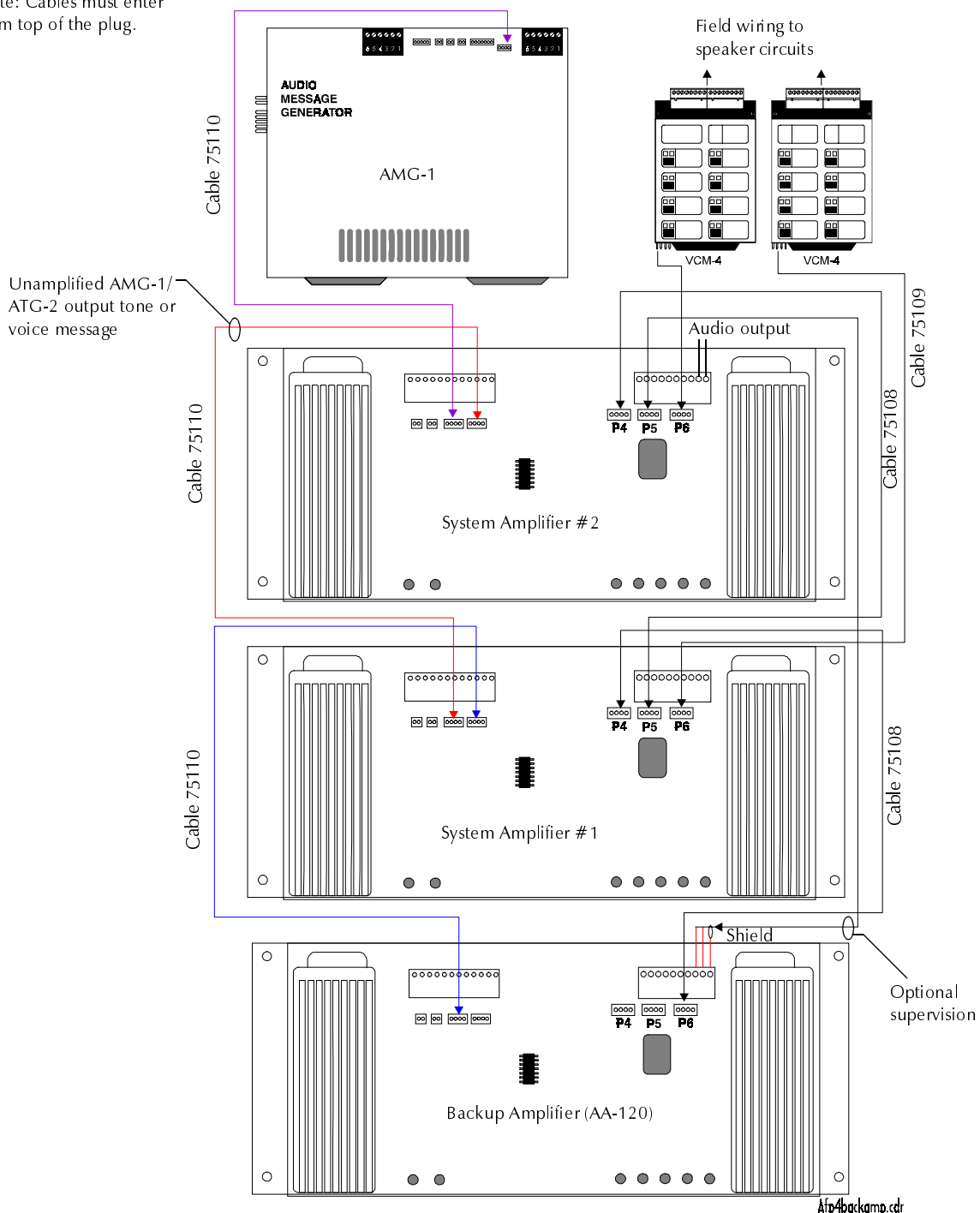

Figure 4-15 System Configuration with a Backup Amplifier

Voice Alarm Modules

Overview

Voice alarm modules for the Unimode 400 feature removable terminal blocks that simplify installation and servicing of the control panel. These modules include the Voice Control Module (VCM-4), the Voice Control Expander (VCE-4), and the Dual Channel Module (DCM-4). For instructions on mounting modules, refer to Section 2, *Installation*.

Module Descriptions

Table 4-10 contains descriptions of the voice alarm modules and the components that come with each module.

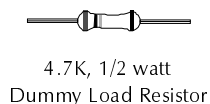
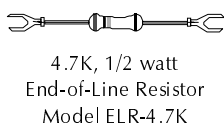

Module	Description	Components
<p>Voice Control Module-4 (VCM-4)</p>  <p>VCM-4</p>	<p>A board that provides the control panel with up to four Style Y or Style Z speaker circuits. Moving a jumper on the VCM-4 sets the VCM-4 to drive telephone (FFT-7/FFT-7S) circuits. When set for telephone operation, a VCM-4 accepts its signal directly from an FFT-7/FFT-7S.</p>	<ul style="list-style-type: none"> • VCM-4 board • four end-of-line resistors (71252) • four dummy load resistors (71245) • one 24-inch cable assembly (71091) for interboard connection • a set of slide-in speaker labels • a set of slide-in telephone labels
<p>Voice Control Expander-4 (VCE-4)</p>  <p>VCE-4</p>	<p>A board that plugs into the back of the VCM-4. This expands the voice unit up to eight Style Y or Style Z speaker circuits. When set for telephone circuit operation, the VCE-4 provides expansion for up to eight Style Y or four Style Z fire Fighter's telephone circuits.</p>	<ul style="list-style-type: none"> • VCE-4 board • four end-of-line resistors (71252) • four dummy load resistors (71245) • one 24-inch cable assembly (71091) • three 1-1/4 inch cables(75106)
<p>Dual Channel Module (DCM-4)</p>  <p>DCM-4</p> <p>VCE-4</p>	<p>A two-board assembly (DCM-4 and VCE-4) that provides the control panel with capability to select one of two audio sources for switching to a selected speaker circuit. The DCM-4 can use up to four circuits.</p>	<ul style="list-style-type: none"> • DCM-4 board • VCE-4 board • four end-of-line resistors (71252) • four dummy load resistors (71245) • one 24-inch cable assembly (71091) • four 24-inch cable assemblies (71091) for interboard connection • six 54 inch cable assemblies (75071) for connecting a DCM-4 to an AMG-1 and AA-30/AA-120s • a slide-in label set (15831)

Table 4-10 Voice Alarm Modules

Connecting VCM-4 Speaker Circuits

Overview

Follow these guidelines when connecting VCM-4 speaker circuits:

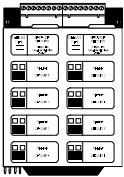
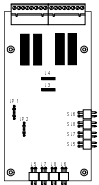
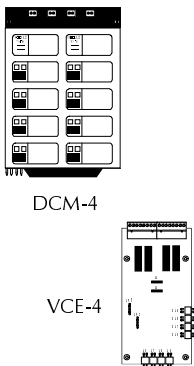
1. Speaker circuits are supervised and power-limited.
2. Use twisted-pair cable for wiring speaker circuits.
3. Maximum speaker circuit wire resistance depends on wattage required for each speaker.
4. Use only UL-listed speakers rated for 25 Vrms.
5. For systems with AA-100 amplifiers, you can use 70.7 Vrms speakers. Use 4.7K, 2W ELRs with 70.7 Vrms speakers.
6. Install End-of-Line resistors according to Table 4-11:

For ELR connection to devices...	Use resistor part number...
with terminals	71252
with flying leads	71245
used in Canada also include	N-ELR Resistor Plate

Table 4-11 VCM-4 Speaker Resistor Requirements

VCM-4 Speaker Wiring Diagram

Figure 4-16 shows typical speaker wiring for a VCM-4 module:

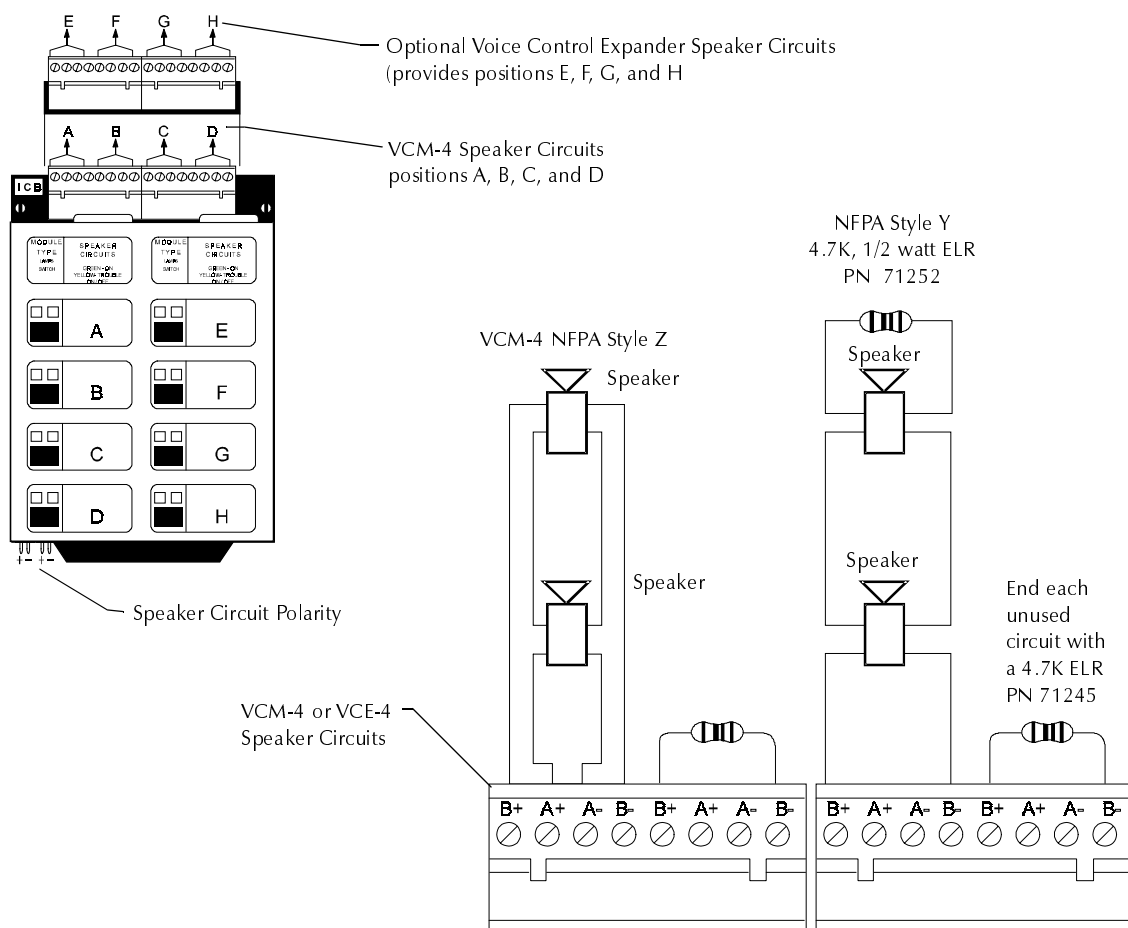

Figure 4-16 Typical Speaker Circuits

Connecting VCM-4 Telephone Circuits

Follow these guidelines when connecting VCM-4 telephone circuits:

- Telephone circuits are supervised and power-limited.
- Use twisted-pair cable for telephone circuit wiring.
- Maximum telephone circuit wire resistance is 40 ohms.
- Install End-of-Line Resistors according to Table 4-12:

For ELR connection to devices...	Use resistor part number...
with terminals	71252
with flying leads	71245
used in Canada also include	N-ELR Resistor Plate

Table 4-12 VCM-4 Telephone Resistor Requirements

Wiring Diagram

Figure 4-17 shows typical telephone wiring for a VCM-4 module:

Note: End each unused VCM-4 circuit with a 4.7K ELR (PN 71245).

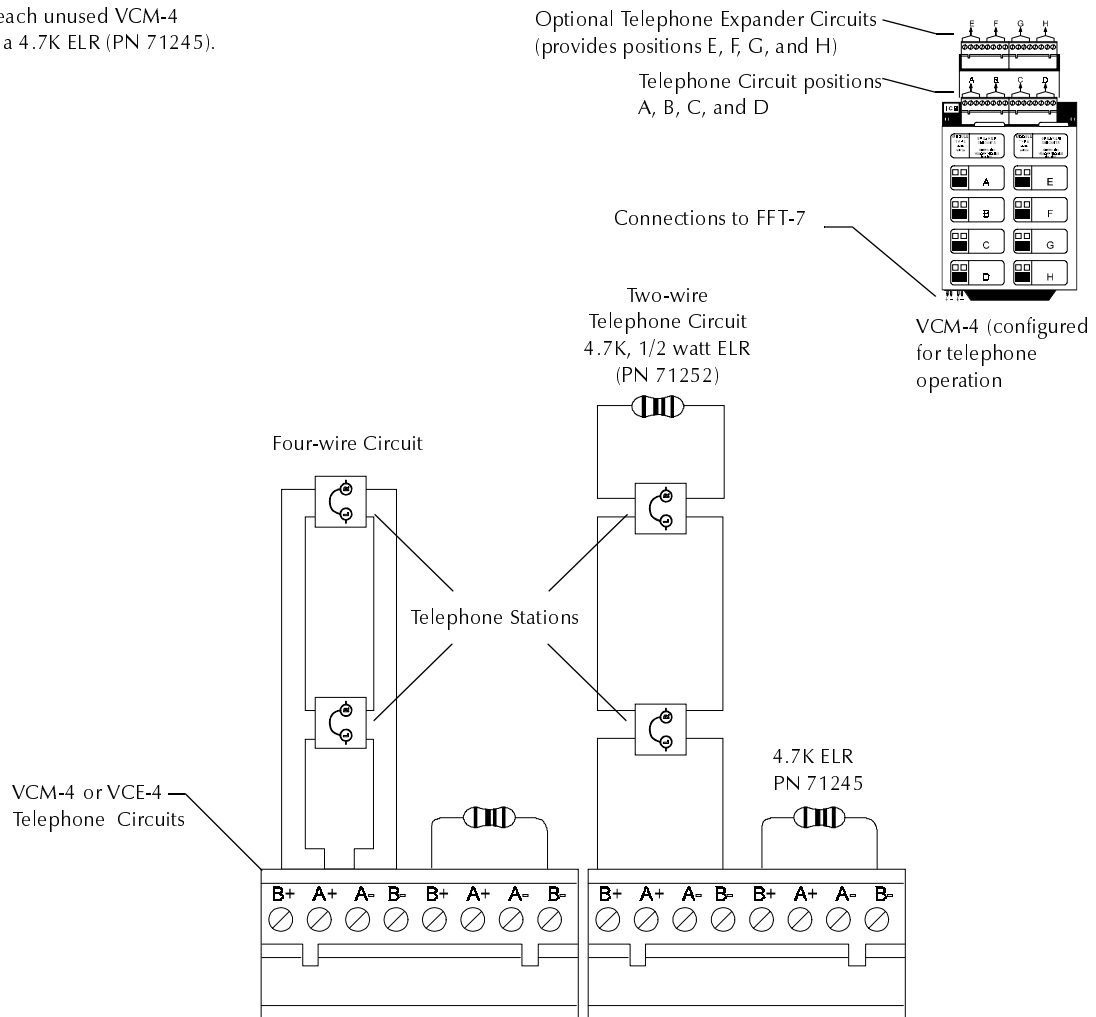

Figure 4-17 Typical Telephone Circuits

Setting the VCM-4 to Speaker or Telephone Mode

The VCM-4 comes with a factory-installed jumper plug on JP3. Use the jumper to select the operating mode of the entire module (VCM-4 plus optional VCE-4). Select Speaker or Telephone mode as detailed in Table 4-13:

Select...	Do this...
Speaker mode (factory setting)	Leave the jumper on JP3.
Telephone mode	1. Remove the jumper from JP3 2. Install the jumper on JP4.

Table 4-13 Selecting Telephone and Speaker Mode

Note: Do not mix speaker and telephone circuits on the same module.

Figure 4-18 shows how to select Speaker or Telephone mode for a VCM-4 module:

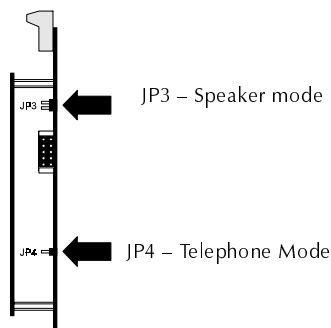
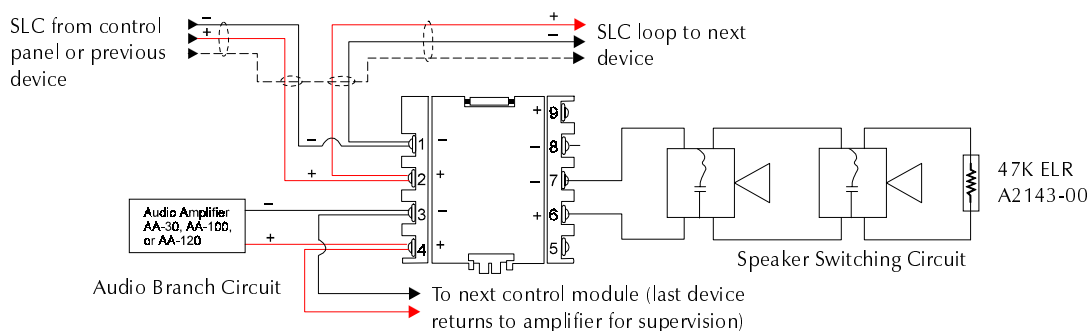

Figure 4-18 Selecting Speaker or Telephone Mode

Connecting a M500CH Module to Speaker Circuits

Figure 4-19 shows typical wiring connections for a M500CH module when installed with speaker circuits. All wiring shown is supervised and power-limited. When making connections, note the following:

- Audio Branch Circuit – Do not loop wire on terminals 3 and 4. Break the wire run to provide supervised connections. Audio circuits require twisted-pair wire as a minimum.
- Speaker Switching Circuit – Only use speakers UL-listed for fire protection. Maximum speaker load: 43.75 watts, up to 70.7 Vrms (0.35 power factor).



Note: Use shielded twisted-pair wire on SLC wiring.

Do not use terminal 5 on the M500CH module.

Figure 4-19 Typical M500CH Wiring Connections to Speaker Circuits

Connecting Dual Channel Module Circuits

Wiring Notes

- All speaker circuits are supervised and power-limited.
- Twisted-pair cable should be used for speaker circuit wiring.
- Maximum speaker circuit wire resistance is dependent upon wattage required at each speaker.
- Refer to Table 4-14 for resistor values.
- Use only UL-listed speakers rated for 25 Vrms.

For ELR connection to devices...	Use resistor part number...
with terminals	71252
with flying leads	71245
used in Canada also include	N-ELR Resistor Plate.

Table 4-14 DCM-4 Resistor Requirements

Wiring Diagram

Figure 4-20 shows typical wiring for M500CH connections to speaker circuits:

Note: For systems with AA-100 amplifiers, you can use 70.7 Vrms speakers. Also, use 4.7K, 2W ELRs with 70.7 Vrms speakers.

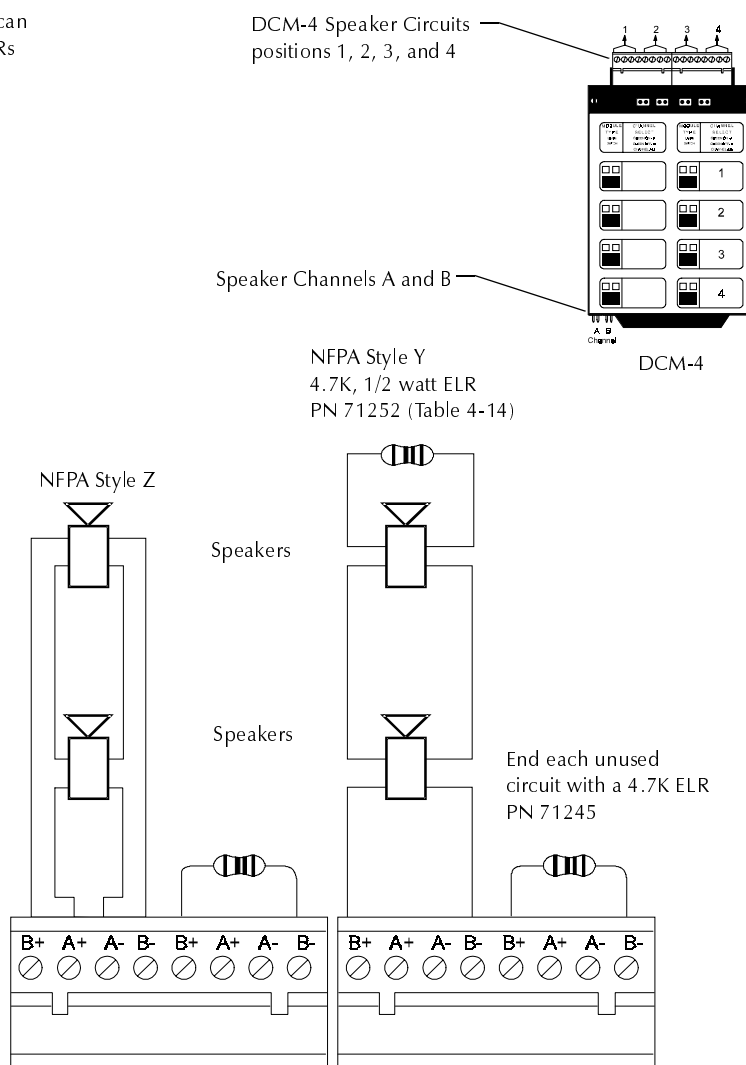

Figure 4-20 Typical Wiring for DCM-4 Speaker Circuits NFWA Style Y

Voice System Configurations

Voice Systems Wiring Overview

This section contains typical configurations for voice systems as outlined in Table 4-15:

Configuration	Refer to...
Internal Power Distribution	Figure 4-21 on page 4-21 Figure 4-22 on page 4-21
CPU EIA-485 Connections	Figure 4-23 on page 4-22 Figure 4-24 on page 4-22
Wiring an Audio Signal without a Backup Amplifier	Figure 4-25 on page 4-23 Figure 4-26 on page 4-23
Audio Signal Wiring Using a Backup Amplifier	Figure 4-27 on page 4-24 Figure 4-28 on page 4-24
CPU Trouble Bus Connections	Figure 4-29 on page 4-25 Figure 4-30 on page 4-25

Table 4-15 Voice System Configurations

Internal Power Distribution

Wiring Diagram

Figure 4-22 shows typical wiring for distributing power within a voice system:

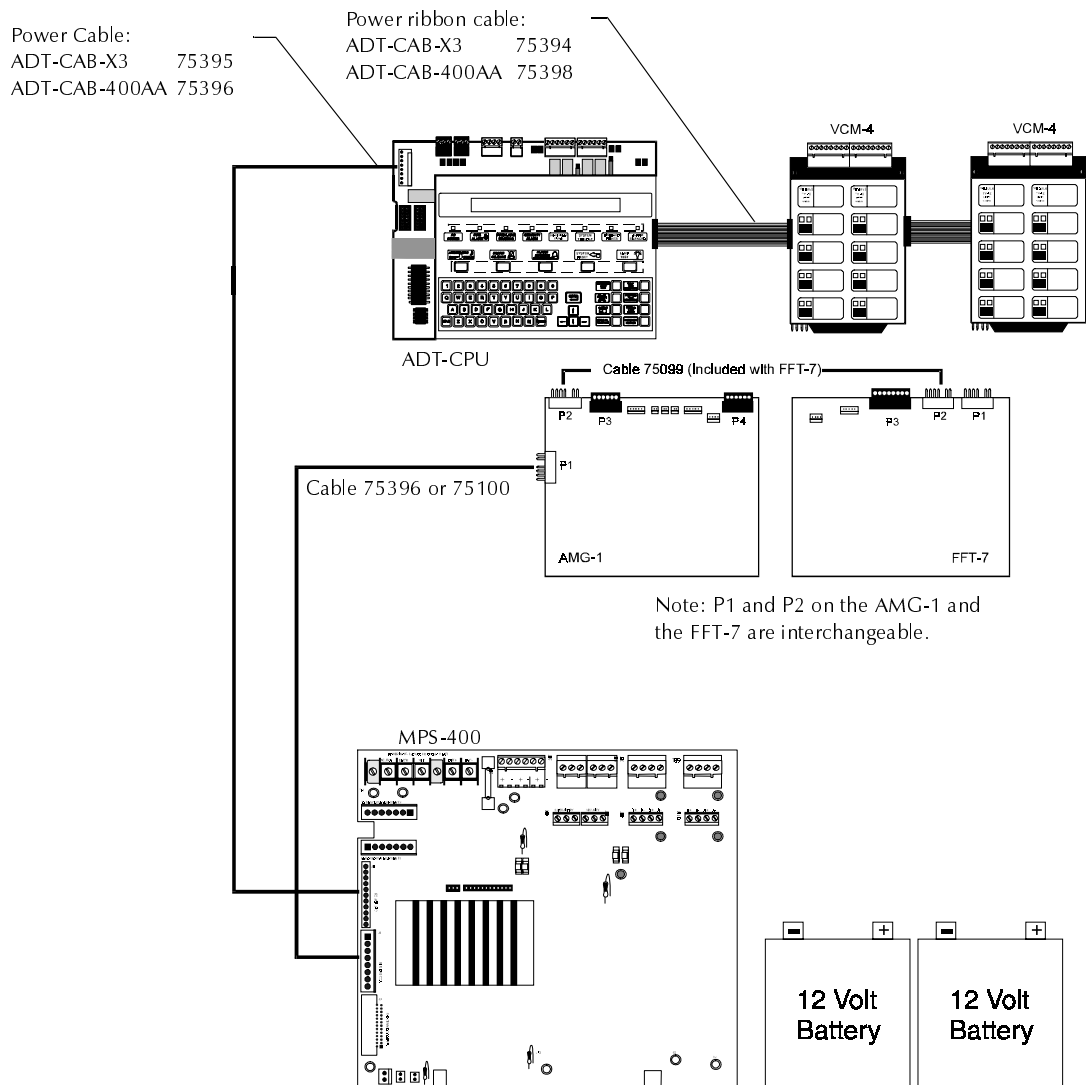

Figure 4-21 System Configuration – Internal Power Distribution

Block Diagram

Figure 4-22 shows a simplified block diagram for distributing internal power within a voice system:

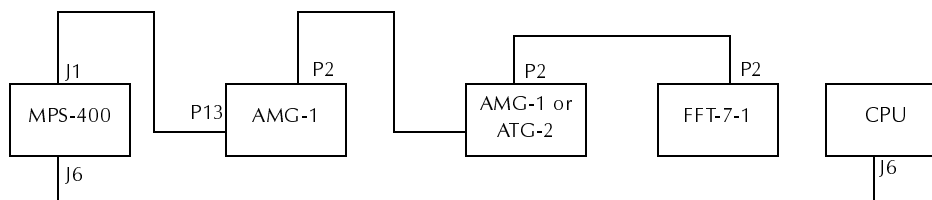

Figure 4-22 Distribution of Internal Power Block Diagram

CPU EIA-485 Connections

Wiring Diagram

Figure 4-23 shows typical wiring of EIA-485 connections between the CPU, AMG-1, and annunciators:

Note: Use 18 AWG to 12 AWG twisted-pair cable for EIA-485 connections.

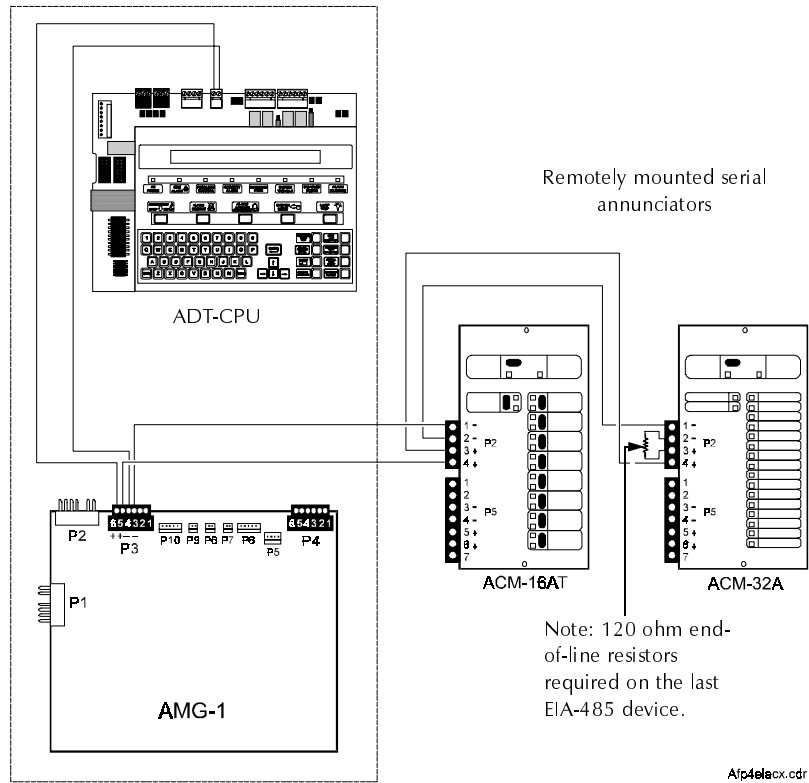

Figure 4-23 CPU EIA-485 Connections

Block Diagram

Figure 4-24 shows a simplified block diagram EIA-485 connections between the CPU and EIA-485 connections:

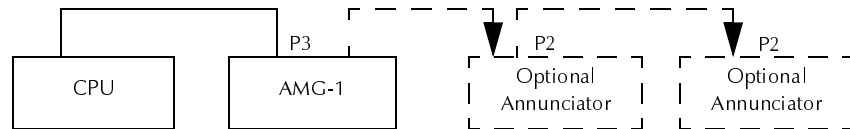

Figure 4-24 Block Diagram for Distribution of EIA-485

Wiring an Audio Signal without a Backup Amplifier

Wiring Notes

Figure 4-25 and Figure 4-26 show the use of two AA-30s without backup. Table 4-16 lists wiring components used in Figure 4-25 and Figure 4-26.

Item	Supplied with	Part Number
Low level Audio cable	AA-30, AA-100, AA-120	75100
Telephone cable	VTCC-1 package	75121
25-volt Audio cable	AA-30, AA-100, AA-120	75109
Cable	FFT-7	75097
470 ohm resistor	AMG-1	R470

Table 4-16 Wiring Inventory

Typical Wiring Diagram Figure 4-25 shows typical wiring of an audio signal without using a backup amplifier:

Note: Use 18 AWG to 12 AWG twisted-pair cable for EIA-485 connections. Mount an R470 resistor across P3-4 and P3-5 on the last amplifier. This wiring diagram applies to AA-30, AA-100, and AA-120 audio amplifiers. Connections to plugs P1, P2, P4, P5, P6, P7, P9, and P10 are identical.

The first two speaker circuits share 30 watts from one AA-30; the third and fourth speaker circuits share 30 watts from the second AA-30.

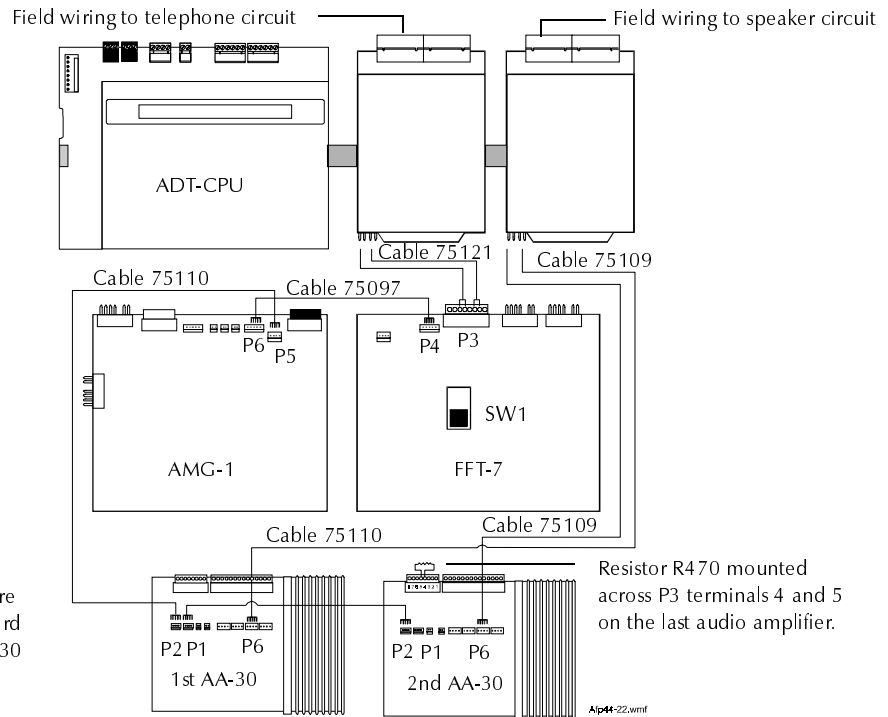

Figure 4-25 Wiring an Audio Signal without a Backup Amplifier

Block Diagram

Figure 4-26 shows a simplified block diagram for wiring an audio signal without using a backup amplifier:

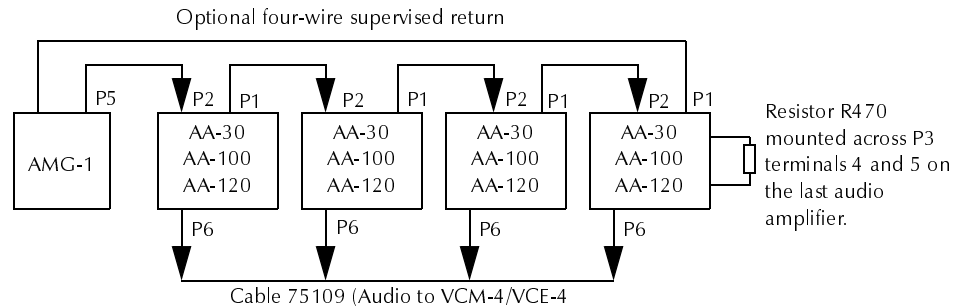

Figure 4-26 Distribution for Audio Block Diagram

Audio Signal Wiring Using a Backup Amplifier

Wiring Notes

Note: Use 18 AWG to 12 AWG twisted-pair cable for EIA-485 connections. This wiring diagram applies to AA-30, AA-100, and AA-120 audio amplifiers. Connections to plugs P1, P2, P4, P5, P6, P7, P9, and P10 are identical.

Figure 4-27 and Figure 4-28 show speaker wiring using two AA-30s with a backup AA-30. Table 4-17 lists the inventory for wiring the speakers.

1. Set FFT-7 SW1 for four-wire operation (down position).
2. Mount resistor R470 across P3-4 and P3-5 on the last amplifier (Figure 4-27).

Item	Supplied with	Part Number
Low level Audio cable	AA-30, AA-100, AA-120	75100
Telephone cable	VTCC-1 package	75121
25-volt Audio cable	AA-30, AA-100, AA-120	75109
Cable	FFT-7	75097
470 ohm resistor	AMG-1	R470

Table 4-17 Wiring Inventory

Wiring Diagram

These four speaker circuits share 30 watts from one AA-30. The AA-30 on the left serves as the backup.

Figure 4-27 shows typical wiring of two AA-30s using one AA-30 as a backup:

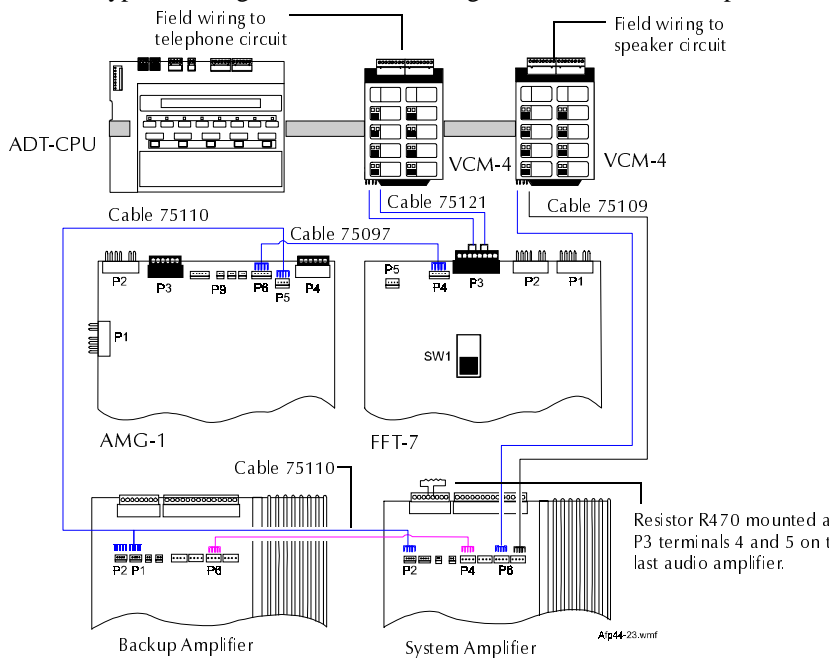

Figure 4-27 Wiring an Audio Signal with a Backup Amplifier

Block Diagrams

Figure 4-28 shows two simplified block diagrams for using a backup amplifier:

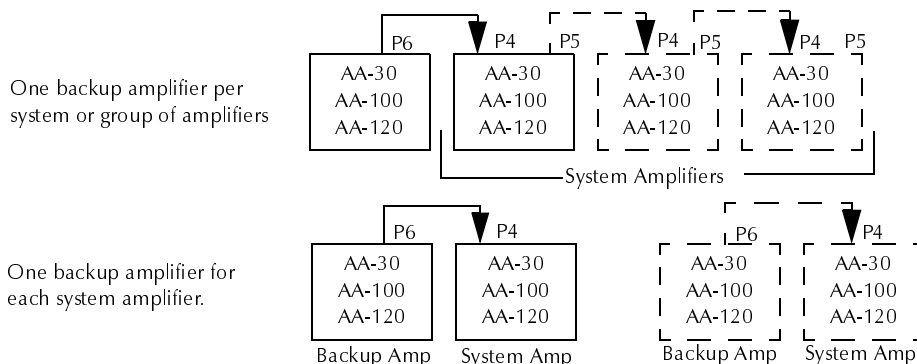

Figure 4-28 Backup Amplifier Block Diagrams

CPU Trouble Bus Connections

Wiring Notes

When connecting the CPU Trouble bus, note the following:

1. P9 and P10 on audio amplifiers (AA-30, AA-100, and AA-120) and P1 and P2 on the AVPS-24 are interchangeable.
2. Trouble cable part numbers are: 75098 (24-inch) or 71033 (60-inch).

Wiring Diagram

Figure 4-30 shows typical wiring for connecting a trouble bus to a CPU:

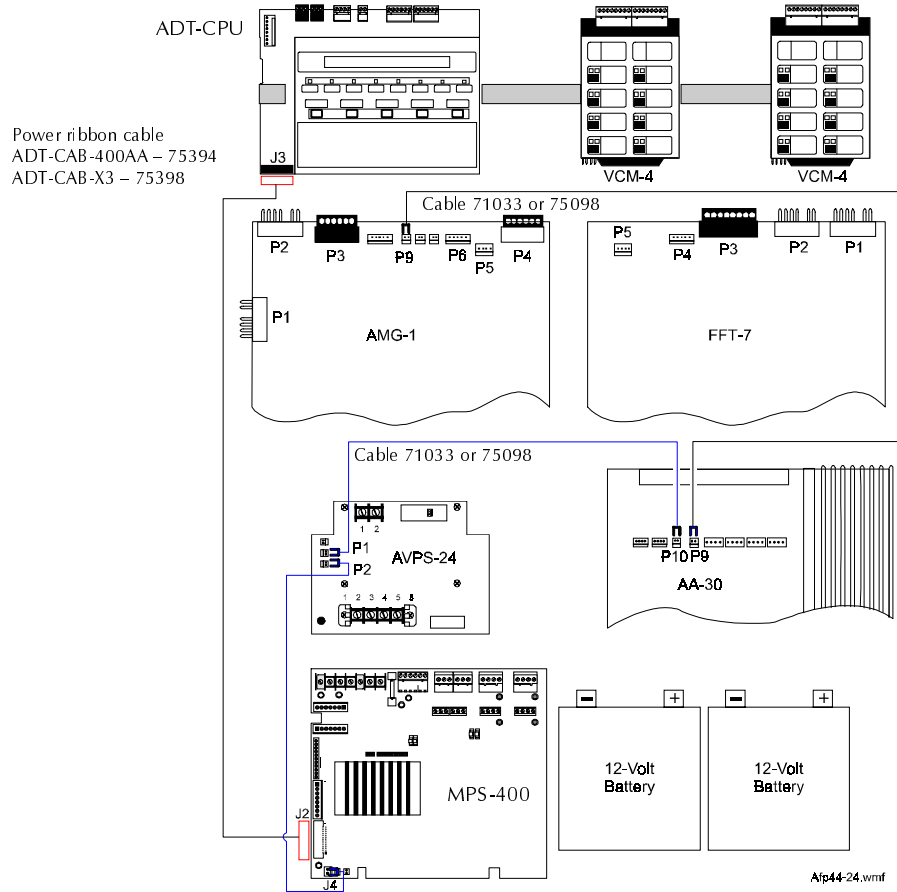

Figure 4-29 CPU Trouble Bus Connections

Block Diagram

Figure 4-30 shows a simplified block diagram for connecting a trouble bus:

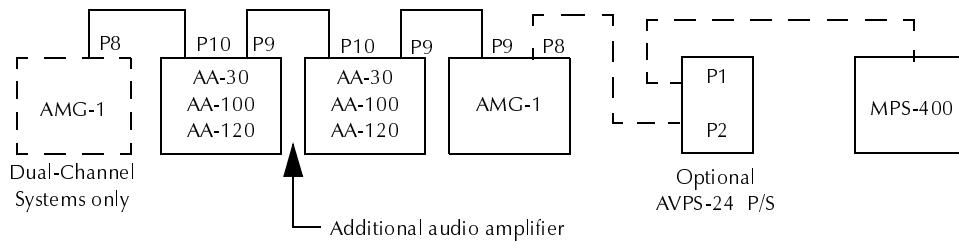

Figure 4-30 Trouble Bus Block Diagram

Wiring Speaker Circuits

Wiring Speaker Circuit Overview

This section contains typical wiring diagrams for wiring speaker circuits in the configurations listed in Table 4-18:

Configuration	Refer to...
30 Watt/Four and Eight Speaker Circuits	Four speakers – Figure 4-31 on page 4-27 Eight speakers – Figure 4-32 on page 4-27
120 Watt/Four and Eight Speaker Circuits	Four speakers – Figure 4-33 on page 4-28 Eight speakers – Figure 4-34 on page 4-28
90 Watt/Eight Speaker Circuit	Figure 4-35 on page 4-29
240 Watt/Eight Speaker Circuit	Figure 4-36 on page 4-30
180 Watt/Eight Speaker Circuit	Figure 4-37 on page 4-31
30 Watt Dual Channel	Figure 4-38 on page 4-32
120 Watt Dual Channel (AA-30s)	Figure 4-39 on page 4-33
120 Watt Dual Channel (AA-120)	Figure 4-40 on page 4-34

Table 4-18 Topics Covered in Wiring Speaker Circuits

30 Watt/Four and Eight Speaker Circuits

Wiring Notes

When wiring four-and eight-speaker circuits using 30 watts of power, note the following:

1. An AA-30 supplies audio power through plug P6, or terminals 5 and 6 on terminal block P8. This audio power run is not supervised. If using the optional supervised return, a loss of audio power (due to a break in the wiring) generates a trouble signal at the AA-30.
2. If using an optional supervised four-wire return, cut resistors R8 and R9, located directly under plug P6 on the AA-30.
3. Each speaker circuit can share a maximum of 30 watts.

Wiring Four Speakers

Figure 4-31 shows typical wiring for wiring four speaker circuits using 30 watts of power:

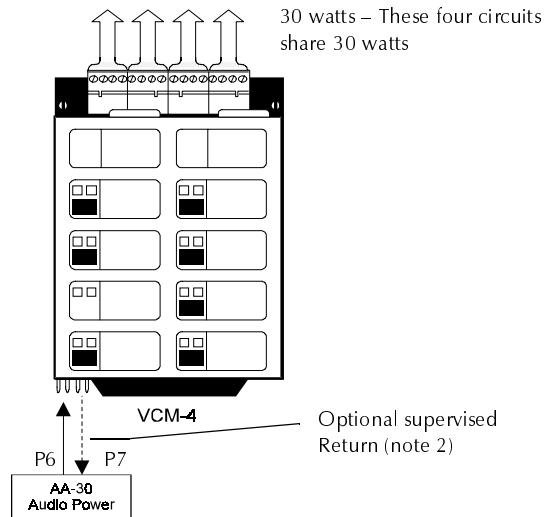

Figure 4-31 Typical 30 Watt, Four-Speaker Circuit

Wiring Eight Speakers

Figure 4-32 shows typical wiring for wiring eight speaker circuits using 30 watts of power:

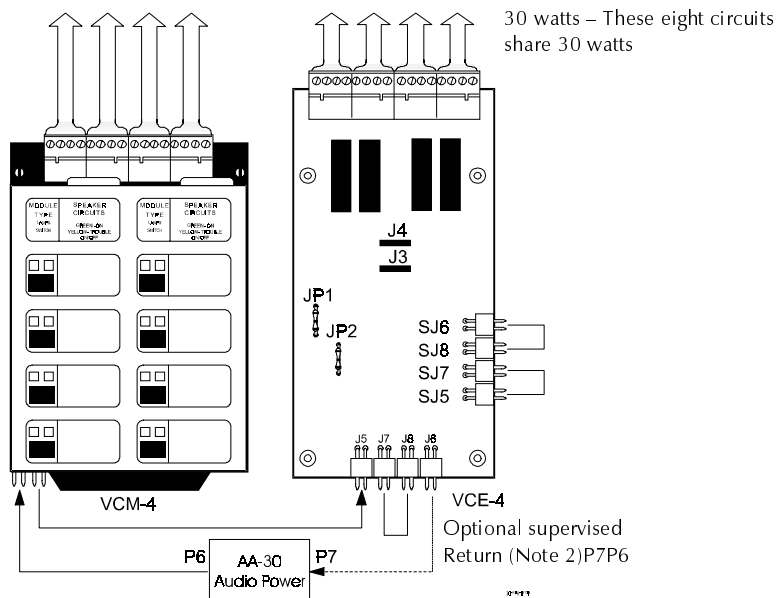

Figure 4-32 Typical 30 Watt, Eight-Speaker Circuit

120 Watt/Four and Eight Speaker Circuits

Wiring Notes

When wiring four-and eight-speaker circuits using 120 watts of power, note the following:

1. The AA-120 draws audio power from plug P6, or terminals 5 and 6 of terminal block P8. This audio power run is not supervised. If using the optional supervised return, a loss of audio power (due to a break in the wiring) generates a trouble signal at the AA-120.
2. If using an optional supervised four-wire return, cut resistor R107 on the AA-120.
3. Each circuit can handle a maximum of 30 watts.

Wiring Four Speakers

Figure 4-33 shows typical wiring for wiring four speaker circuits using 120 watts of power:

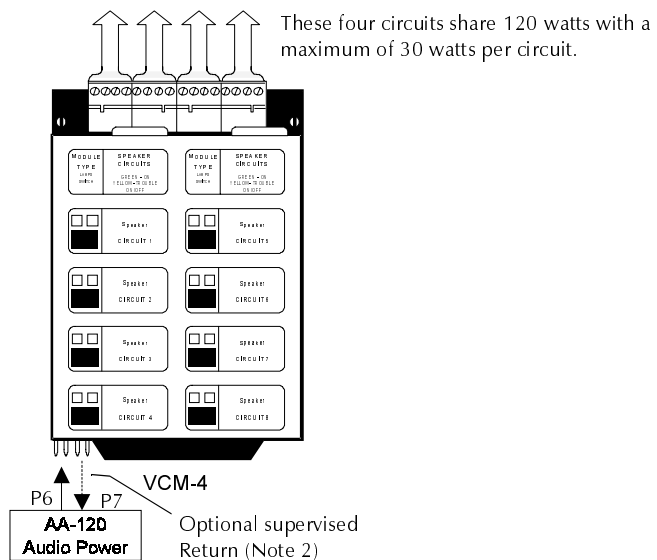

Figure 4-33 Typical 120-Watt, Four-Speaker Circuit

Wiring Four Speakers

Figure 4-34 shows typical wiring for wiring eight speaker circuits using 120 watts of power:

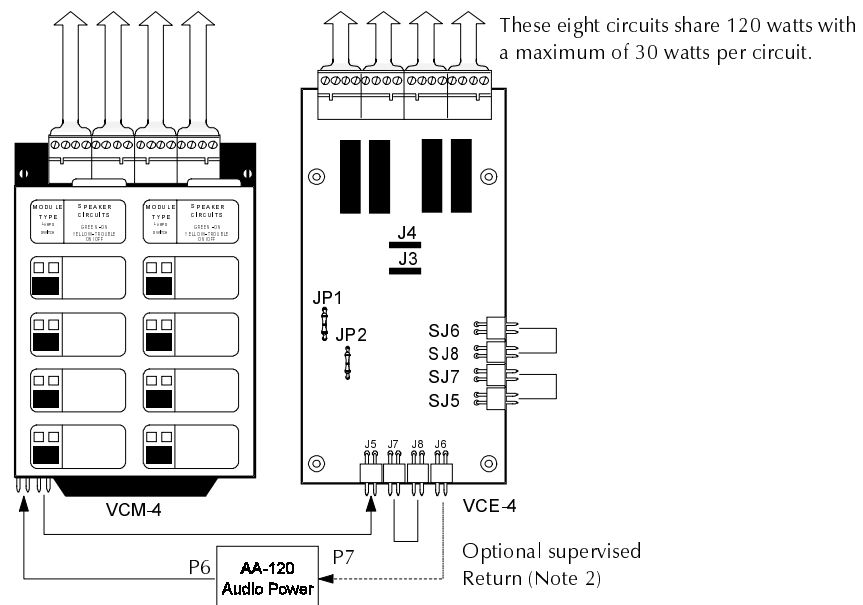

Figure 4-34 Typical 120-Watt, Eight-Speaker Circuit

90 Watt/Eight Speaker Circuit Configuration

Wiring Notes

When wiring eight speaker circuits using 90 watts of power, note the following:

1. The AA-30 supplies audio power through plug P6, or terminals 5 and 6 on terminal block P8. (This audio power run is not supervised.) If using the optional supervised return, a loss of audio power (due to a break in the wiring) will generate a trouble signal at the AA-30.
2. If using an optional supervised four-wire return, cut resistors R8 and R9, located directly below plug P6 on the AA-30.
3. Each circuit can handle a maximum of 30 watts.
4. In the configuration shown below, cut VCE-4 jumpers JP1 and JP2.

Wiring Diagram

Figure 4-35 shows typical wiring for a 90-watt (VCM-4 provides 30 watts and the VCE-4 provides 60 watts), eight-speaker circuit:

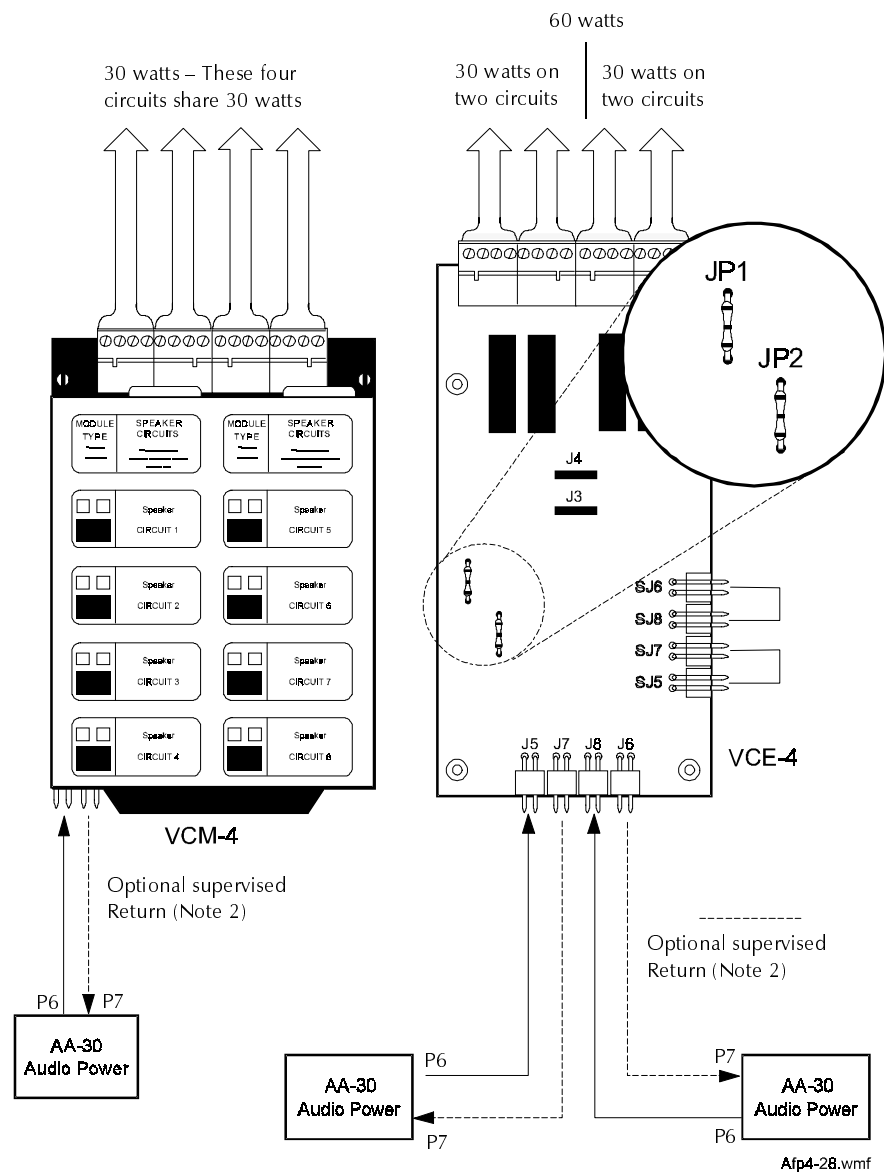

Figure 4-35 Typical 90-Watt, Eight-Speaker Circuit

240 Watt/Eight Speaker Circuit

Wiring Notes

When wiring eight speaker circuits using 240 watts of power, note the following:

1. The AA-120 draws audio power from plug P6, or terminals 5 and 6 of terminal block P8. This audio power run is not supervised. If using the optional supervised return, a loss of audio power (due to a break in the wiring) will generate a trouble signal at the AA-120.
2. If using an optional supervised four-wire return, cut resistor R100 on the AA-120.
3. Each circuit can handle a maximum of 30 watts.

Wiring Diagram

Figure 4-36 shows typical wiring for a 240-watt, eight-speaker circuit:

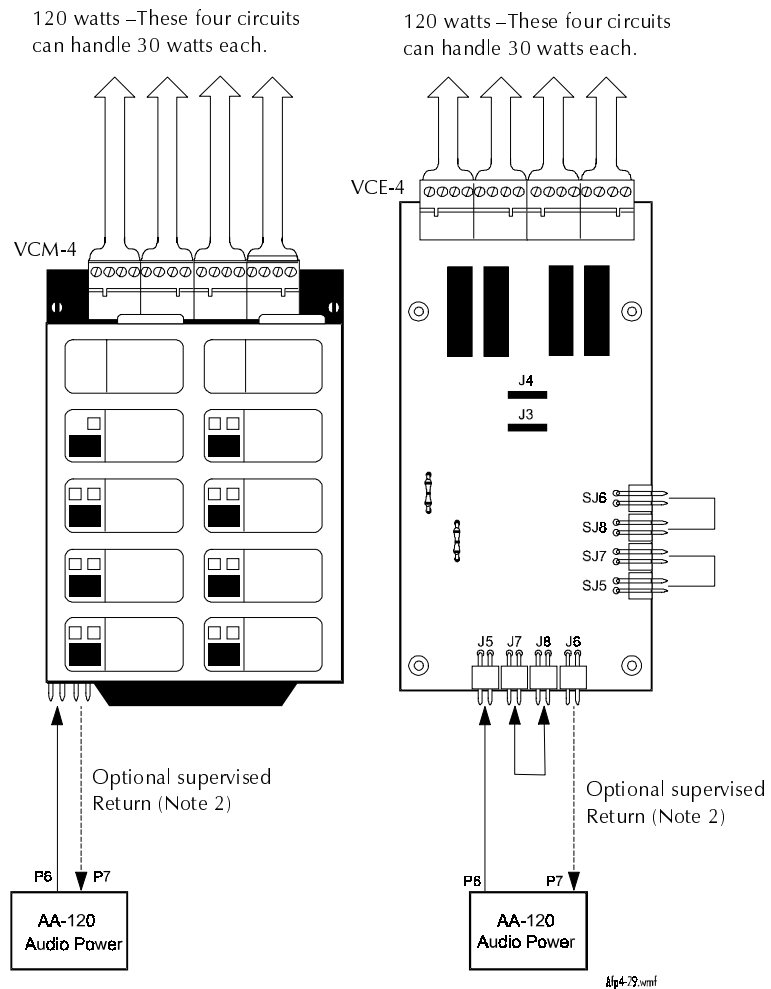

Figure 4-36 Typical 240-Watt, Eight-Speaker Circuit

180 Watt/Eight Speaker Circuit Configuration

Wiring Notes

When wiring eight speaker circuits using 180 watts of power, note the following:

1. AA-30 audio power is drawn from plug P6 or terminals 6 and 7 of terminal block P8. This audio power run is not supervised. If using the optional supervised return (plug P7 or terminals 2 and 3 of block P8), a loss of audio power due to a break in the wiring will generate a trouble signal at the AA-30.
2. If using an optional supervised four-wire return, cut resistors R8 and R9 (for the location of R8 and R9, see Figure 4-37).
3. Each circuit can handle a maximum of 30 watts.
4. In this configuration, cut VCE-4 and VCM-4 jumpers JP1 and JP2.

Wiring Diagram

Figure 4-37 shows typical wiring for a 180-watt, eight-speaker circuit:

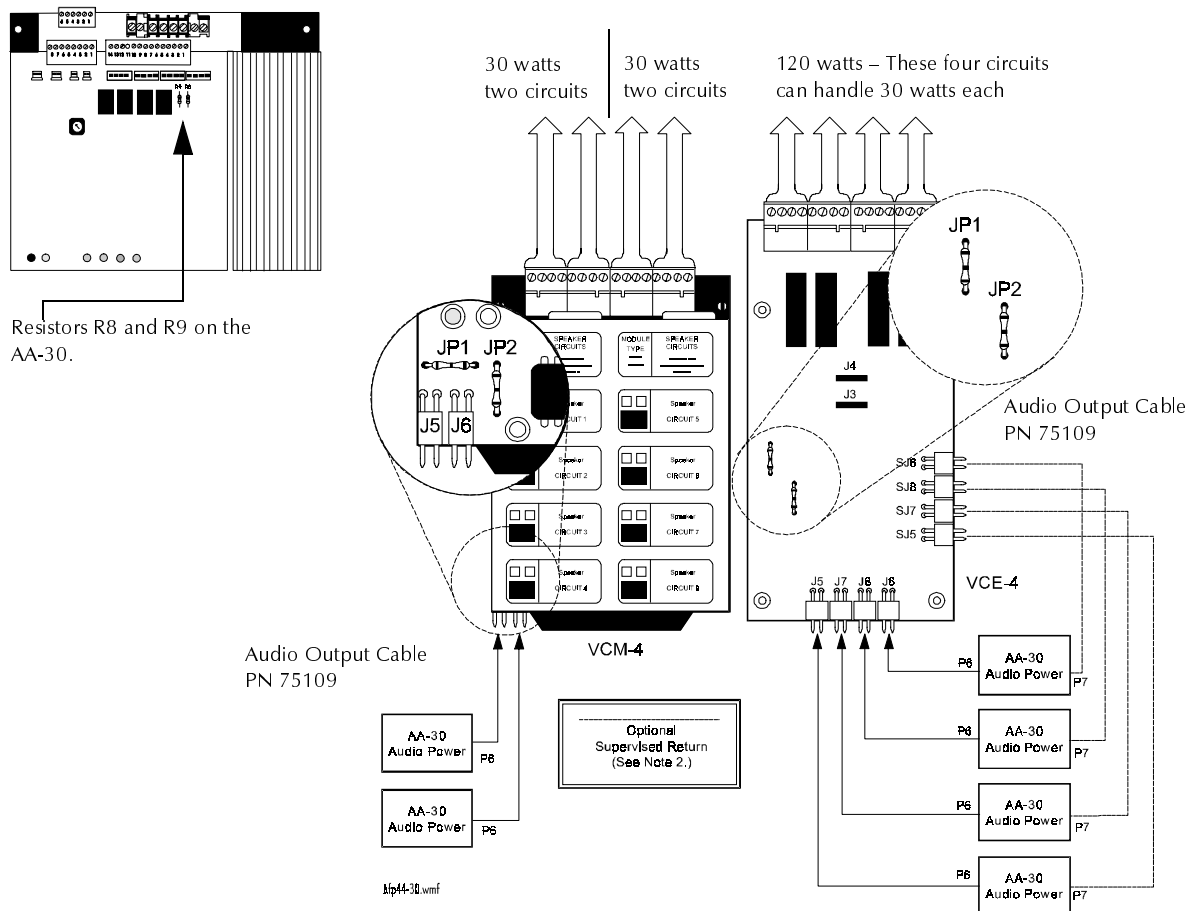

Figure 4-37 Typical 180-Watt, Eight-Speaker Circuit

30 Watt Dual-Channel Configuration

Wiring Notes

When wiring circuits in a dual-channel configuration using 30 watts of power, note the following:

1. Plug P6 or terminals 5 and 6 of terminal block P8 provide AA-30 audio power. This audio power run cannot be supervised in this configuration.
2. Maximum power is 30 watts per circuit.
3. For dual-channel operation, cut VCE-4 jumpers JP1 and JP2 (Figure 4-38).

Wiring Diagram

Figure 4-38 shows typical wiring for a 30-watt, dual-channel configured circuit:

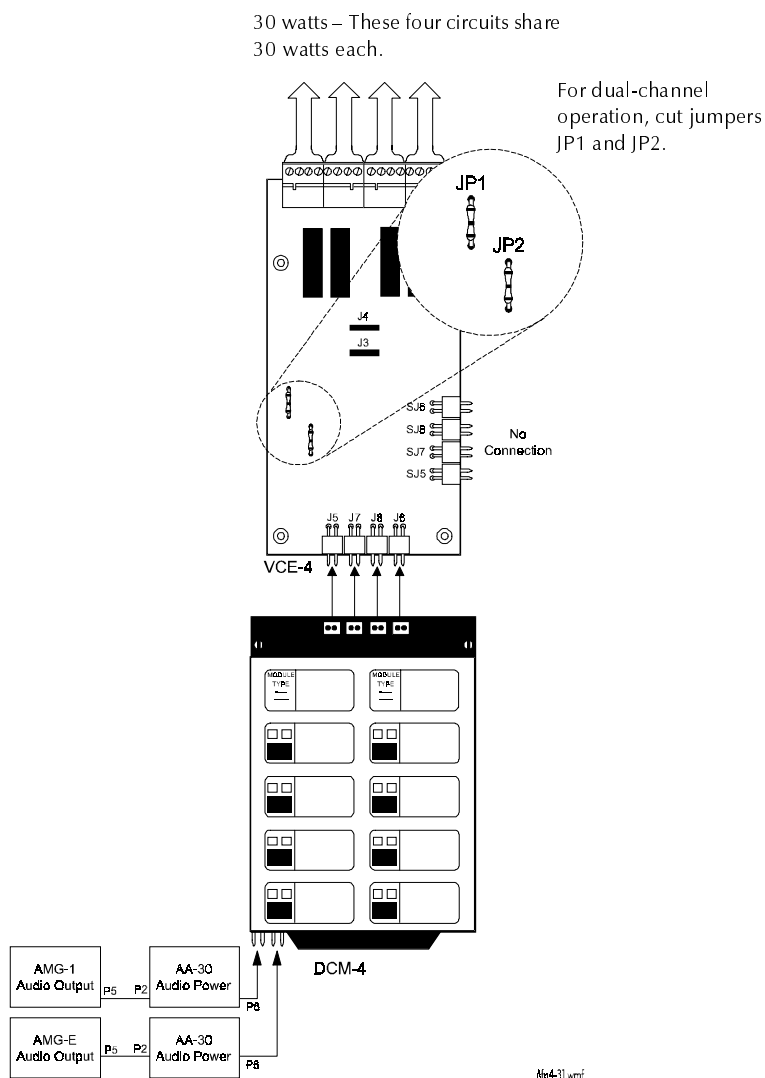

Figure 4-38 Typical 30-Watt Dual Channel Configuration

120 Watt Dual-Channel Configuration (Four AA-30s)

Wiring Notes

When wiring circuits in a dual-channel configuration using 120 watts of power with four AA-30s, note the following:

1. AA-30 audio power is drawn from plug P6 or terminals 6 and 7 of terminal block P8. (This audio power run is not supervised.) If using the optional supervised return (plug P7, or terminals 2 and 3 of terminal block P8), loss of audio power due to a break in the wiring generates a trouble signal at the AA-30.
2. If using an optional supervised return, cut resistors R8 and R9 on the AA-30 (for location of R8 and R9, see Figure 4-39).
3. Maximum power per circuit equals 30 watts.
4. For dual-channel operation, cut VCE-4 jumpers JP1 and JP2 (Figure 4-39).

Wiring Diagram

Figure 4-39 shows typical wiring for a 120-watt (using four AA-30s), dual-channel configured circuit:

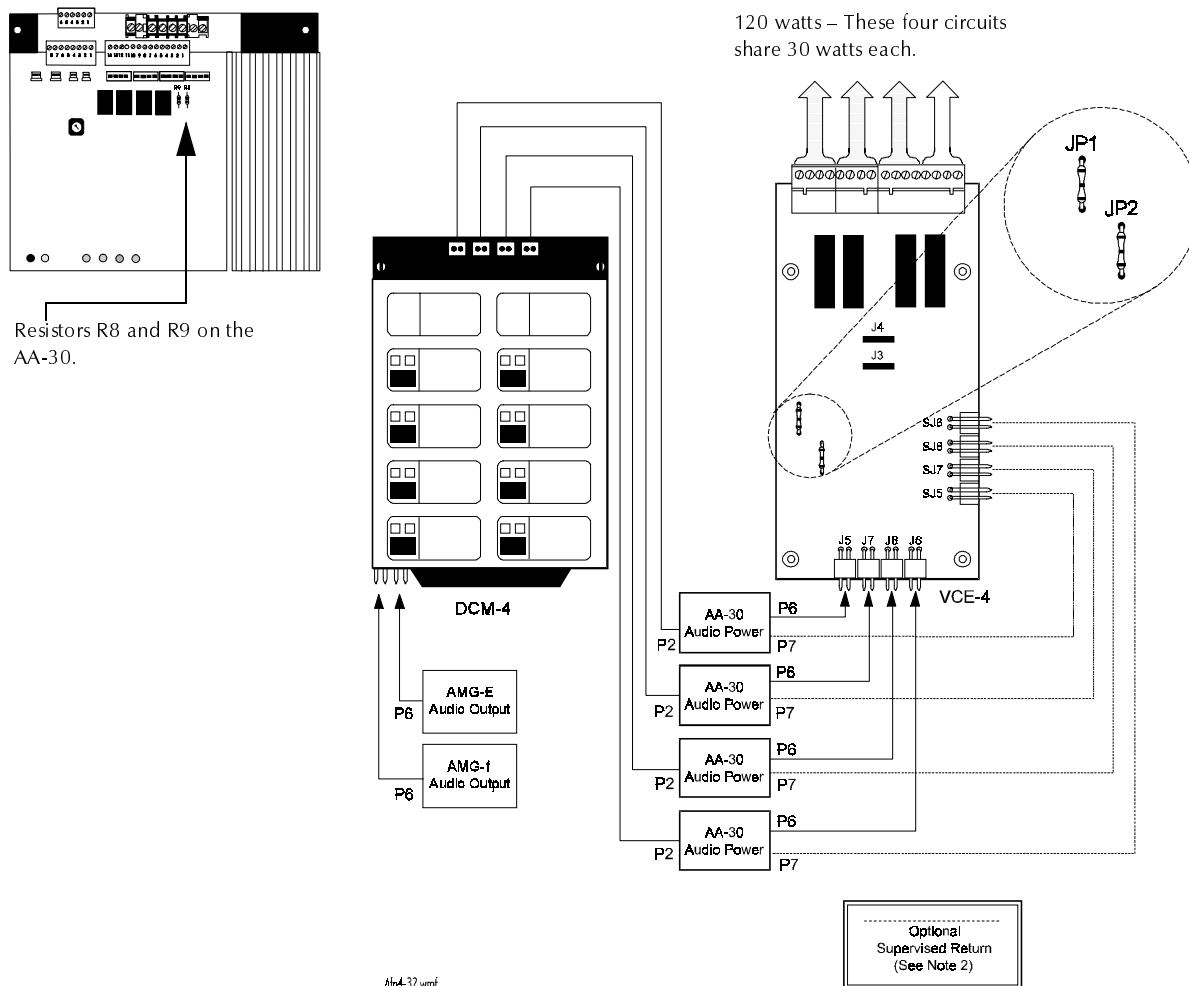

Figure 4-39 Typical 120-Watt Dual Channel Configuration (AA-30)

120 Watt Dual-Channel Configuration (Two AA-120s)

Wiring Notes

When wiring circuits in a dual-channel configuration using 120 watts of power with two AA-120s, note the following:

1. AA-120 audio power is drawn from plug P6 or terminals 5 and 6 of terminal block P8. This audio power run cannot be supervised in this configuration.
2. Each circuit can handle a maximum of 30 watts.
3. In this configuration, cut VCE-4 jumpers JP1 and JP2.

Wiring Diagram

Figure 4-40 shows typical wiring for a 120-watt (using two AA-120s), dual-channel configured circuit:

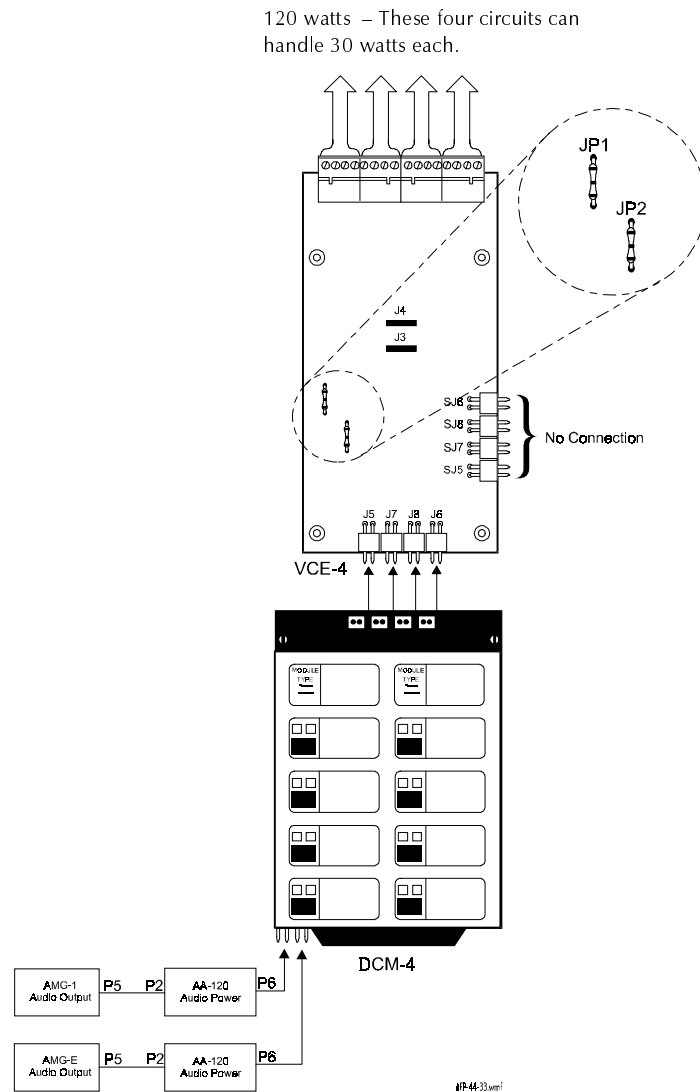

Figure 4-40 Typical 120-Watt Dual Channel Configuration (AA-120)

Voice Message Options (VROM and VRAM)

Overview of VROM and VRAM

You can install two types of message chips into an AMG-1:

VROM – A nonvolatile memory chip containing a factory-programmed evacuation message (up to 24 seconds). You can install one or two VROMs into an AMG-1. Refer to Document 15945 for contents of available VROMs.

VRAM – A programmable memory chip that contains a user-created evacuation message up to 24 seconds long. Create a message from the AMG-1 microphone or a cassette tape. You can install one or two VRAMs into an AMG-1.

Installing VROM and VRAM

To install the VROM and VRAM chips, follow the steps in Table 4-19 and refer to Figure 4-41:

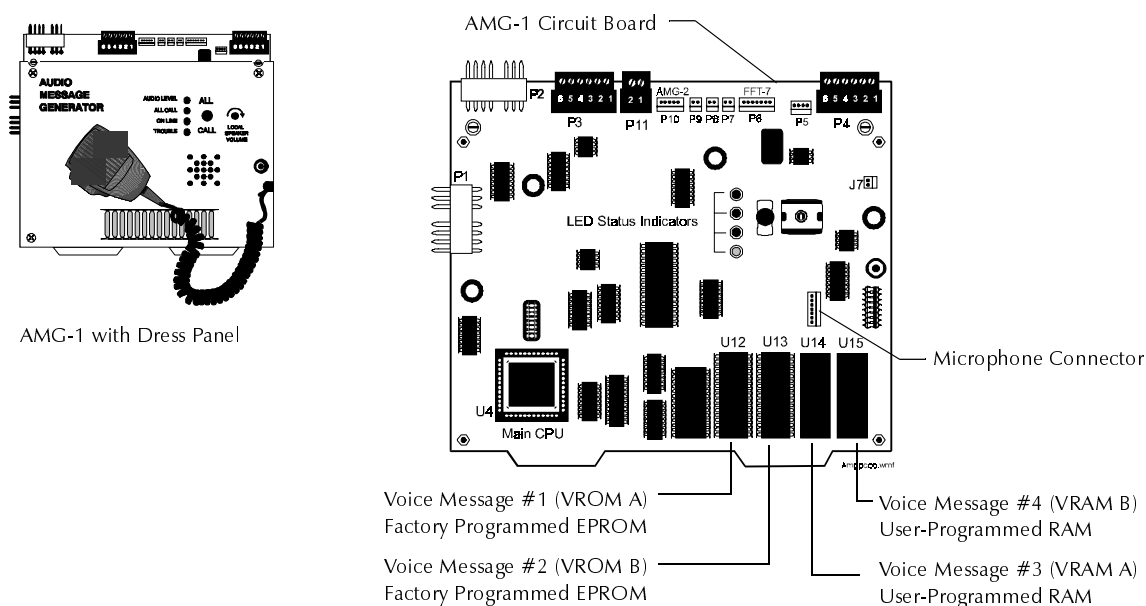

Figure 4-41 AMG-1 Dress Panel and Circuit Board

To install VROM or VRAM chips, follow the steps in Table 4-19.



Caution: Remove AC power at the main service circuit breaker (not the circuit breaker on the main power supply):

Step	Action
1	Remove battery power, then remove AC power from the Unimode 400.
2	Remove the dress panel covering the AMG-1.
3	Remove the four screws that hold the AMG1 dress panel to the component board as shown below. Remove the dress panel and disconnect the microphone connector.
4	Install the VROM or VRAM chips in the positions as shown below
To assemble the AMG-1, reverse these instructions.	

Table 4-19 Installing VROM and VRAM

ACT-1 Audio Coupling Transformer

ACT-1 Overview

The ACT-1 Audio Coupling Transformer couples low-level audio to audio amplifiers or other audio inputs, such as the ATG-2. An ACT-1 can be used to couple a low-level audio signal to up to eight devices in the same cabinet. It provides electrical isolation between low-level audio riser and equipment to which the signal is to be fed (amplifiers or the ATG-2). Also, the ACT-1 provides common mode noise rejection (CMNR), greatly reducing crosstalk from Signaling Line Circuits.

You can install the ACT-1 in any application that uses AA-30, AA-100, or AA-120 audio amplifiers, subject to the following restrictions:

- The amplifiers must mount remotely from the source of low-level audio devices, such as an AMG or ATG.
- The power supplies in the main control panel cabinet and the remote cabinets do not share the same common.
- Ground fault is enabled on each power supply.

Isolated power supplies, each with respective ground fault detection circuits enabled, are often used to aid the quick location of ground faults in large systems. This task is more difficult if the entire system (main and all remote devices) share the same common and the power supply in the main control panel cabinet provides ground fault detection.

In larger systems, capacitance becomes a critical factor in creating sporadic and difficult-to-find ground faults along a single common connection. In these systems—as in systems that expand—use an ACT-1 if possible.

Isolating Power Supplies

For example, take a system consisting of a remote annunciator powered from a local supply within the same cabinet—but connected through an EIA-485 circuit—to the main control panel (Figure 4-42). A common connection occurs (although a poor one) along the EIA-485 interface. Therefore, the power supplies in this system are not adequately isolated and problems will occur. In this case, the earth fault detection of the remote power supply must be disabled and a good common connection must be made between the two systems. An ACT-1 is not required for amplifiers mounted in this remote cabinet but installation of an ACT-1 can reduce CMN from the SLC. Figure 4-42 shows a block diagram of a remote annunciator powered from a local power supply:

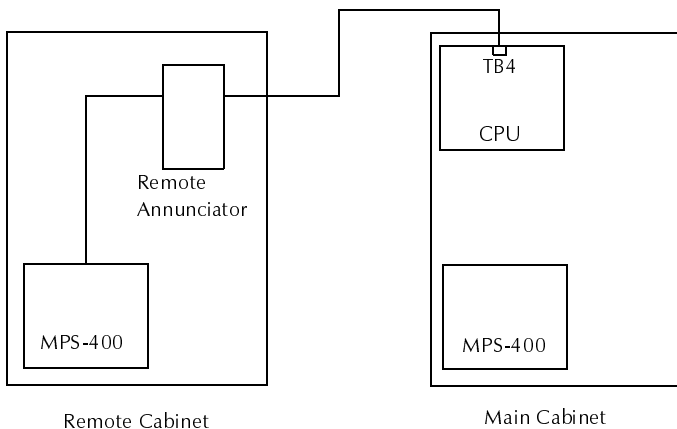

Figure 4-42 Remote Annunciator Powered from a Local Power Supply

ACT-1 Installation

Installation Notes

The ACT-1 connects to one of up to eight amplifiers on a channel. Multiple ACT-1s are required for amplifiers on multiple channels.

To install an ACT-1, follow these steps:

1. Connect the low-level audio circuit to the terminal block on the ACT-1.
2. Connect the ACT-1 to the first amplifier in the chain.

Installation Diagram

Figure 4-43 shows ACT-1 connections:

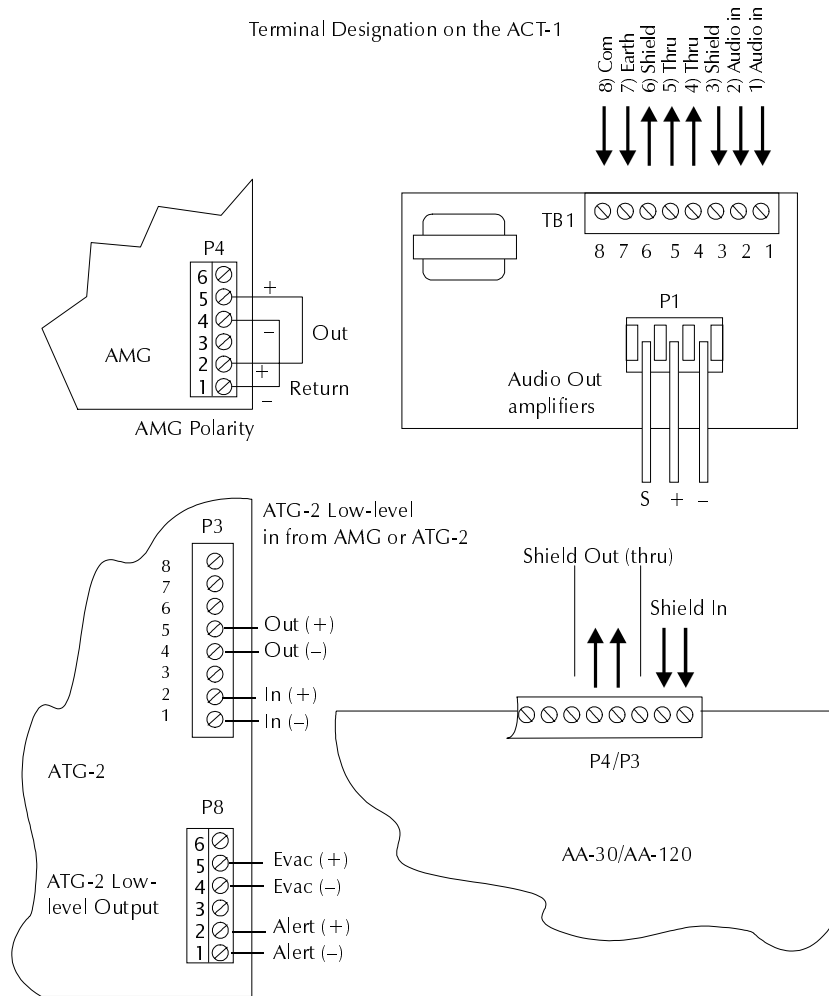

Figure 4-43 ACT-1 Connections

Connecting the ACT-1

Connect an ACT-1 as follows:

Step	Action
1	Using the supplied cable, connect the Earth ground terminal on each ACT-1 to P8 on the AA-100/AA-120 or to a screw on the upper left corner of the AA-30. The COMN terminal is intended for optional shielding of the secondary side of the ACT-1 (low-level audio from the ACT-1 through each amplifier). To use shield, connect to the common of the local power supply—but do not connect this shield to the shield from the primary side of the ACT-1.
2	Daisy-chain the secondary side of the ACT-1 (low-level audio) up to a maximum of eight amplifiers.
3	Draw additional low level audio risers (isolated from the main riser) from P4 on an audio amplifier.

Table 4-20 Connecting an ACT-1

Notes

5. Applications

Applications Overview

Table 5-1 contains an index to sections and topics covered in Section 5:

Section	Covers the following topics
"Central or Remote Station Fire Alarm System (UDACT)" on page 5-2	Installing and configuring a UDACT with the control panel.
"Auxiliary Fire Alarm System" on page 5-3	How to wire for an Auxiliary Fire Alarm System (Municipal Box connected to a 4XTM).
"NFPA 72-1993 Remote Station Fire Alarm System" on page 5-4	How to wire a NFPA 72-1993 Remote Station Fire Alarm System (Fire•Lite RS82 Remote Station Receiver).
"ADT Network Interface Board (ADT-NIB-96)" on page 5-5	How to connect an ADT-NIB-96 to a control panel, including SLC and EIA-485 Connections.
"Using the XP Transponder with the Unimode 400" on page 5-7	How to wire an XP Series Transponder to the CPU.
"Combination Fire/Security Applications/Security Applications" on page 5-8	How to use the control panel as a combination Fire/Security and Security system, including the following: <ul style="list-style-type: none"> • Installing a Security Tamper Switch into the ADT-CAB-400AA. • Installing a Security Tamper Switch into the ADT-CAB-X3. • Circuit Wiring.
"Universal Zone Coder (ADT-UZC-256)" on page 5-11	How to install the ADT-UZC-256 and to do the following: <ul style="list-style-type: none"> • Wire 12 Zone-Coded NACs. • Wire 20 Zone-Coded NACs.
"Releasing Applications" on page 5-16	How to install the following releasing applications: <ul style="list-style-type: none"> • a Releasing Device to the MPS-400. • a Releasing Device to an ICM-4/ICE-4 Module. • a Releasing Device to an M500CH Module. • an N-ARA-10 Agent Release-Abort Station. • a Combination Waterflow/Supervisory Valve Monitor.

Table 5-1 Unimode 400 Applications

Central or Remote Station Fire Alarm System (UDACT)

Installation

Figure 5-1 shows typical wiring diagram for a NFPA 72-1993 Central Station Fire Alarm System (Protected Premises Unit) or a Remote Station Fire Alarm System (Protected Premises Unit) using the UDACT and control panel. Connect and program the Universal Digital Alarm Communicator/Transmitter (UDACT) according to the directions given in the UDACT Installation Manual (Document 50050).

Wiring Diagram

Figure 5-1 shows typical wiring between a UDACT and the control panel:

Note: An NFPA 72 Central Station requires 24 hours of standby power; an NFPA 72 Remote Station requires 60 hours of standby power.

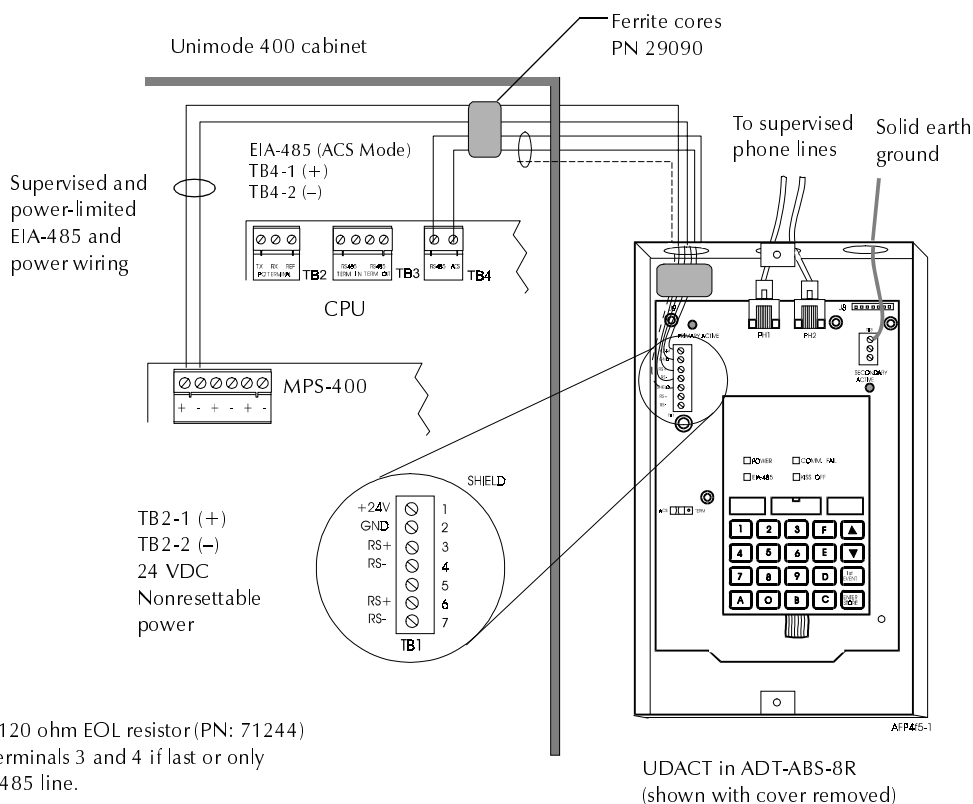

Figure 5-1 Typical Wiring Diagram for a Central Station Fire Alarm System

Auxiliary Fire Alarm System

Overview

Figure 5-2 shows typical wiring for an Auxiliary Fire Alarm System (Municipal Box connected to a 4XTM). Note the following:

Note: NFPA 72 Auxiliary requires 60 hours of standby power.

1. The Local Energy Municipal Box circuit is nonpower-limited. Maintain at least a 0.25 inch space between the Municipal Box Circuit wiring and all power-limited circuit wiring.
2. Municipal Box wiring can leave the building.
3. Maximum Municipal Box circuit resistance allowed for wiring from the control panel to the municipal box is 3 ohms. Electrical values for the Auxiliary Fire Alarm System are listed in Table 5-2:

Item	Value
Supervisory current	5.0 mA
Trip current	0.35 A (subtracted from notification appliance power)
Coil voltage	3.65 VDC
Coil resistance	14.6 ohms

Table 5-2 Auxiliary Fire Alarm System Electrical Values

Wiring Diagram

Figure 5-2 shows a typical wiring diagram of 4XTM connected to a Municipal Box:

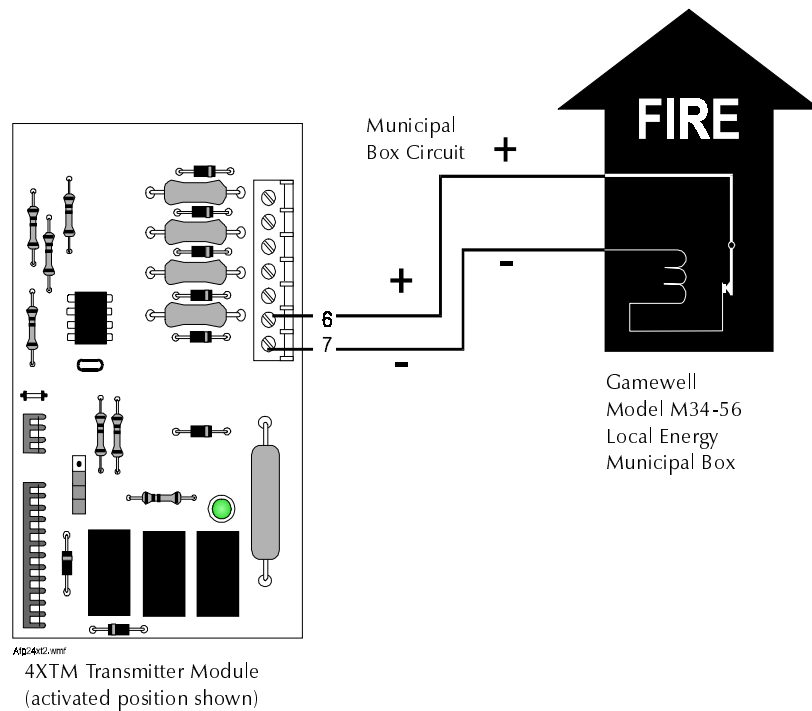

Figure 5-2 NFPA 72-1993 Auxiliary Fire Alarm System

NFPA 72-1993 Remote Station Fire Alarm System

Overview

Figure 5-3 shows typical wiring for NFPA 72-1993 Remote Station Fire Alarm System (UL-listed Fire-Lite Alarms, Inc. RS82 Remote Station Receiver). Note the following:

1. This application is intended for connection to a polarity reversal circuit of a remote station receiving unit with compatible ratings.
2. All connections are power-limited and supervised except the reverse polarity loop.
3. Circuit supervision is the responsibility of the receiver.
4. Remote Alarm and Remote Trouble wiring can leave the building.
5. Maximum load for each circuit: 10 mA; Reverse polarity output voltage: 24 VDC (nominal) or 28 VDC (max).

Wiring Diagram

Figure 5-3 shows typical wiring for NFPA 72-1993 Remote Station Fire Alarm System:

Note: Refer to Fire-Lite Alarms, Inc., Instruction Manual for the Remote Station Receiver Model RS82.

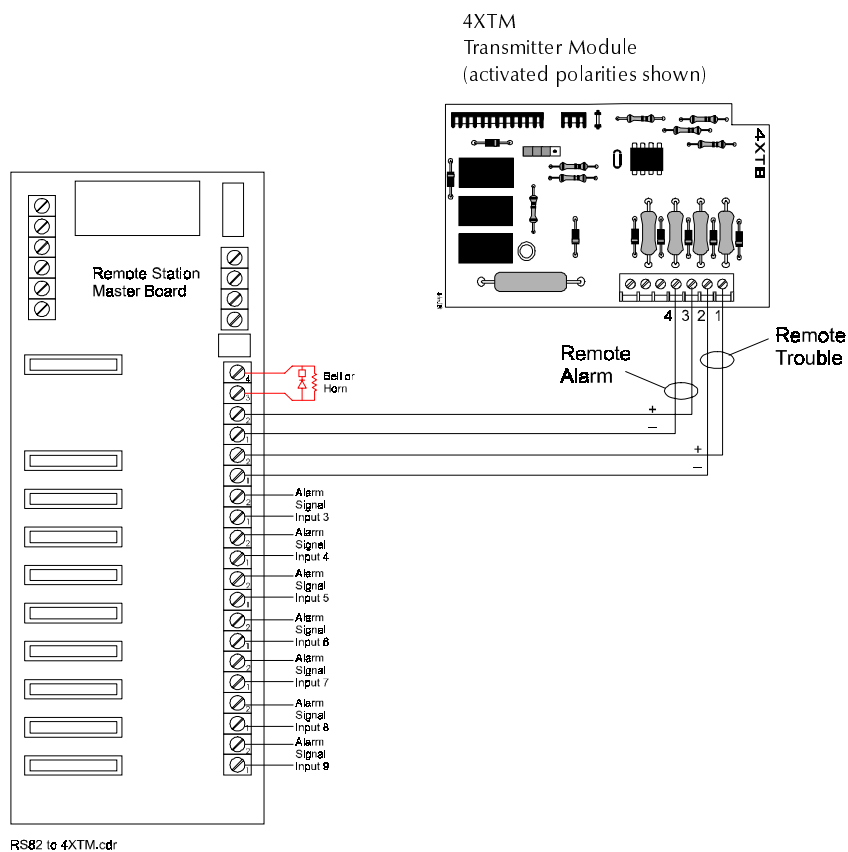

Figure 5-3 Remote Station Connection Using a 4XTM Module

ADT Network Interface Board (ADT-NIB-96)

ADT-NIB-96 Overview

The ADT Network Interface Board (ADT-NIB-96) is a microprocessor-controlled module that connects slave fire alarm control panels to a master fire control panel. Typically, ADT-NIB-96 modules are physically located in each slave control panel, which can contain 8 to 96 input/output points. This section contains board and wiring information for connecting an ADT-NIB-96 to a Unimode 400 control panel.

Circuit	Requirements
Power	24 VDC power-limited
Standby	22 mA
Alarm	22 mA

Table 5-3 ADT-NIB-96 Power Requirements

ADT-NIB-96 Assembly

Figure 5-4 shows terminal connections and switches on an ADT-NIB-96 board:

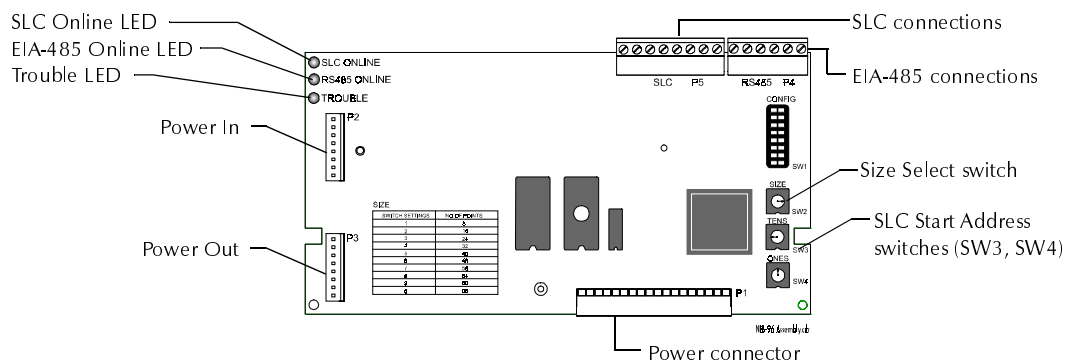

Figure 5-4 Network Interface Board

Item	Description
Trouble LED	Yellow LED lights during loss of communications on EIA-485 or SLC loop.
EIA-485 Online LED	Green LED blinks during communication with the slave FACP.
SLC Online LED	Green LED blinks during communication with the master FACP.
SLC and EIA-485 connections	All connections are power-limited and supervised. See Sections 3, 4, and 5 for details on connection requirements. See Figure 5-5 for terminal assignments.
Power In	Connects ADT-NIB to the Main Power Supply (if not mounted in an ICA-4/L).
Power Out	Connection to other equipment.
Power connector	Not used.
SLC Start Address switches	Set to 01 through 99. (Note that the sum of Address and Size cannot exceed 99.)
Size Select switch	Switch that lets you select the number of points (select 1-8) monitored on the slave panel.

Table 5-4 Network Interface Board Components

ADT-NIB-96 SLC and EIA-485 Connections

Figure 5-5 shows the pinouts for SLC (P5) and EIA-485 (P4) connections on the ADT-NIB-96 board. The EIA-485 circuit requires a serial connection. Connect only one wire to each screw terminal.

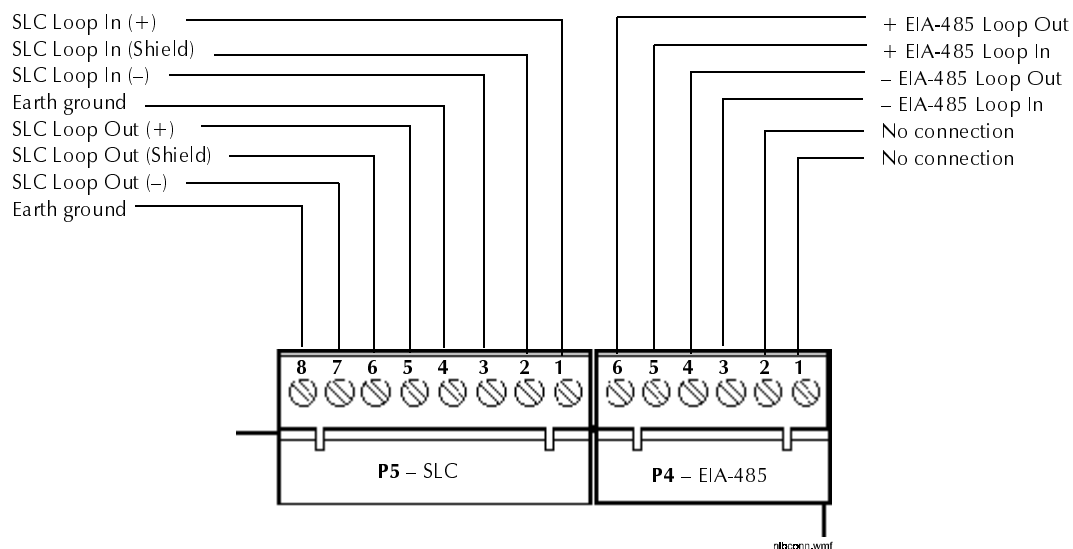

Figure 5-5 SLC and EIA-485 Connections

Wiring Specifications

Table 5-5 contains the wiring specifications for wiring an SLC and an EIA-485 circuit:

Circuit	Wiring Specifications
SLC Loop	Supervised and power-limited Maximum wiring distance: 10,000 feet at 12 AWG Maximum loop current: 200 mA (short circuit) or 100 mA (normal) Maximum loop resistance: 40 ohms
EIA-485	Supervised and power-limited ±5 volts peak-to-peak Maximum wiring distance: 6000 feet at 14 AWG Maximum circuit resistance: 40 ohms Characteristic impedance of wiring: 120 ohms Transmission rate: 2400 baud

Table 5-5 ADT-NIB-96 Wiring Specifications

Using the XP Transponder with the Unimode 400

XP Transponder Overview

The XP Series Transponder is a multiplex subsystem that communicates directly with the CPU through an SLC loop. If the CPU fails or loses power, the XP can operate in a degraded stand-alone mode. To the Unimode 400, XP Transponder circuits appear as individual addressable monitor or control modules. For more information, refer to the XP Transponder manual.

Wiring Diagram

Figure 5-6 shows typical wiring between an XP Series Transponder and the CPU:

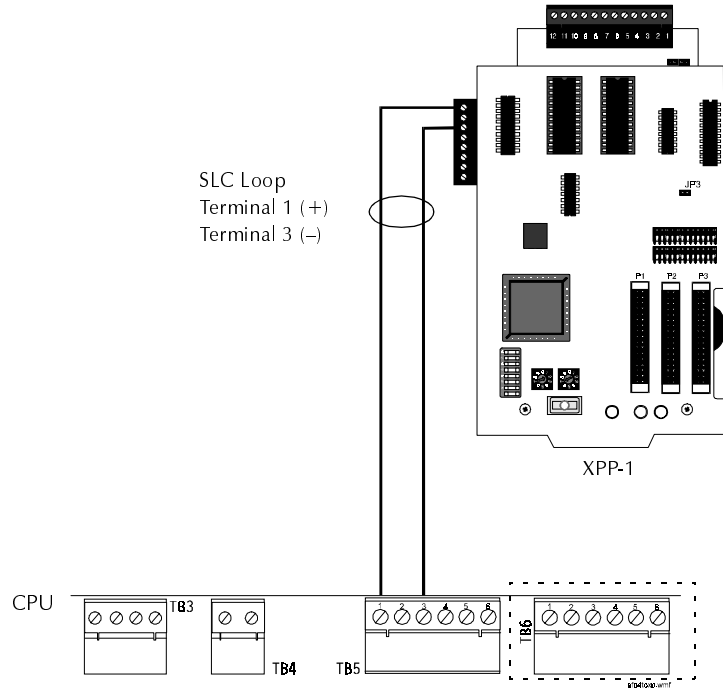

Figure 5-6 Connecting an XP Transponder to the CPU

Combination Fire/Security Applications/Security Applications

Overview

You can use the control panel as a combination Fire/Security and Security system when operated according to the instructions in this section.

General Operation

For security applications, program one or more M500M modules with the Security ALA type code, and wire as shown in Figure 5-10. Activating this type of M500M module lights the Security LED, and displays a Security alarm condition on the control panel LCD. The panel sounder will sound until you press <Acknowledge>. You can also program additional sounders or output devices to activate with the Security alarm initiating device. The Security ALA type circuit is designed to indicate an alarm as follows: (a) on an open or short circuit; or (b) on a $\pm 50\%$ change in resistance value from the end-of-line resistor value.

A tamper switch installed in the cabinet door will indicate a Door Tamper condition whenever the door is open. If the control panel indicates a Security ALA condition, you can acknowledge, silence, or reset the condition from the control panel.

When the system resets, a 30-second exit timer starts. During this time the tamper switch and all Security ALA type alarms are ignored. There is no entrance delay timer.

For bypass of security zones, use the DISABLE routine (covered in the *Status Change* section of the Unimode 400 Operations Manual) for Security ALA type devices.

Installing a Security Tamper Switch

Wire the cabinet with a security tamper switch kit (Figure 5-7). ADT-CAB-400AA cabinets require tamper switch model STS-200; ADT-CAB-X3 cabinets require model STS-1.

Installing a Security Tamper Switch into the ADT-CAB-400AA

1. Install the STS-200 Tamper Switch onto the ADT-CAB-400AA as shown in Figure 5-7.
2. Connect the STS-200 connector to J5 ("Tamper") on the MPS-400.

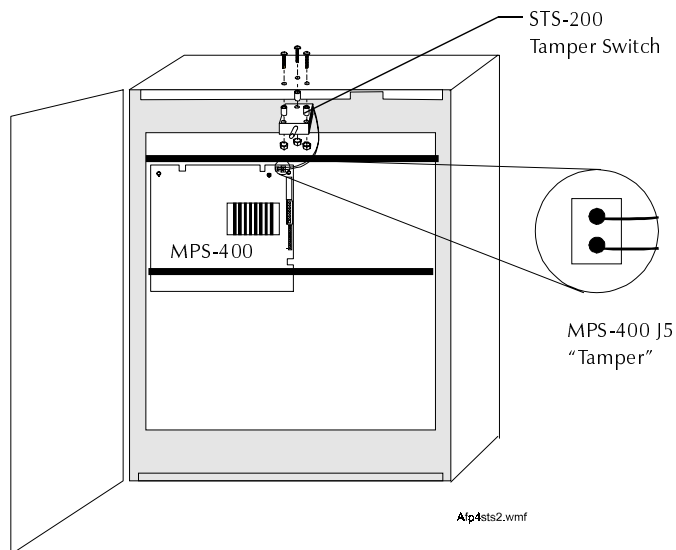

Figure 5-7 Installing the STS-200 Tamper Switch

Installing a Security Tamper Switch into the ADT-CAB-X3

1. Install the STS-1 tamper switch onto the side of the backbox opposite the door hinge.
2. Push the STS-1 through the opening in the backbox until the switch snaps into place.
3. Install the magnet on the same side of the cabinet door as the lock. Push the magnet through the opening in the door until the magnet snaps into place.
4. Connect the STS-1 connector to J5 (Tamper) on the MPS-400.

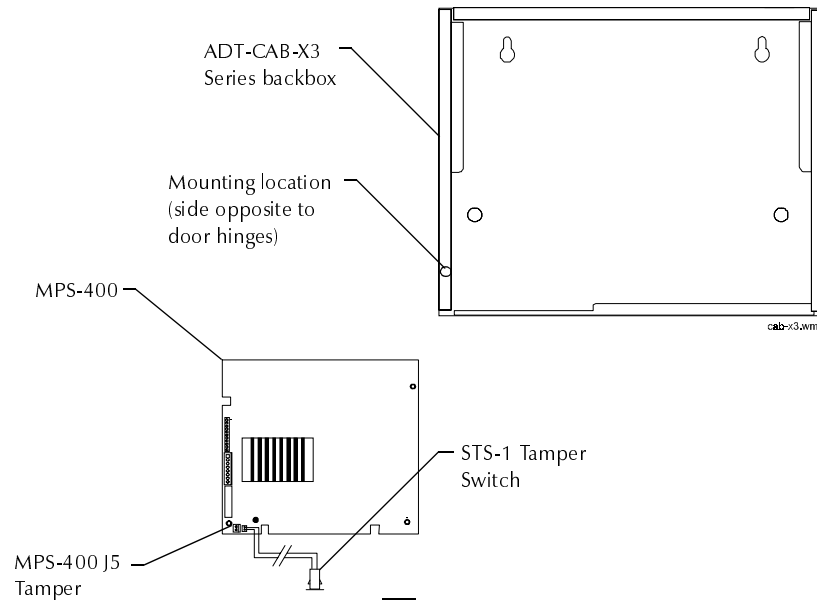

Figure 5-8 Installing the STS-1 Security Tamper Switch

Programming

The control panel can communicate with any number of Security ALA type code devices. To do so, program the points as follows:

1. Select the address of the monitor module(s) to be used for security; and
2. Set the type code to Security ALA.

Note: For detailed instruction on programming type codes, refer to the Unimode 400 Programming Manual.

Wiring for Proprietary Security Alarm Applications

Figure 5-9 shows typical wiring for proprietary Security alarm applications with an M500CH configured as a Notification Appliance Circuit. Note the following:

1. The M500CH is configured as a Notification Appliance Circuit (do not break tabs) and programmed in the Protected Premises Unit.
2. Supplementary use only applies to UL-listed systems.

Note: M500Ms are programmed with software type Security ALA.

Refer to Device Compatibility Document A15378 for compatible Notification Appliance Circuits.

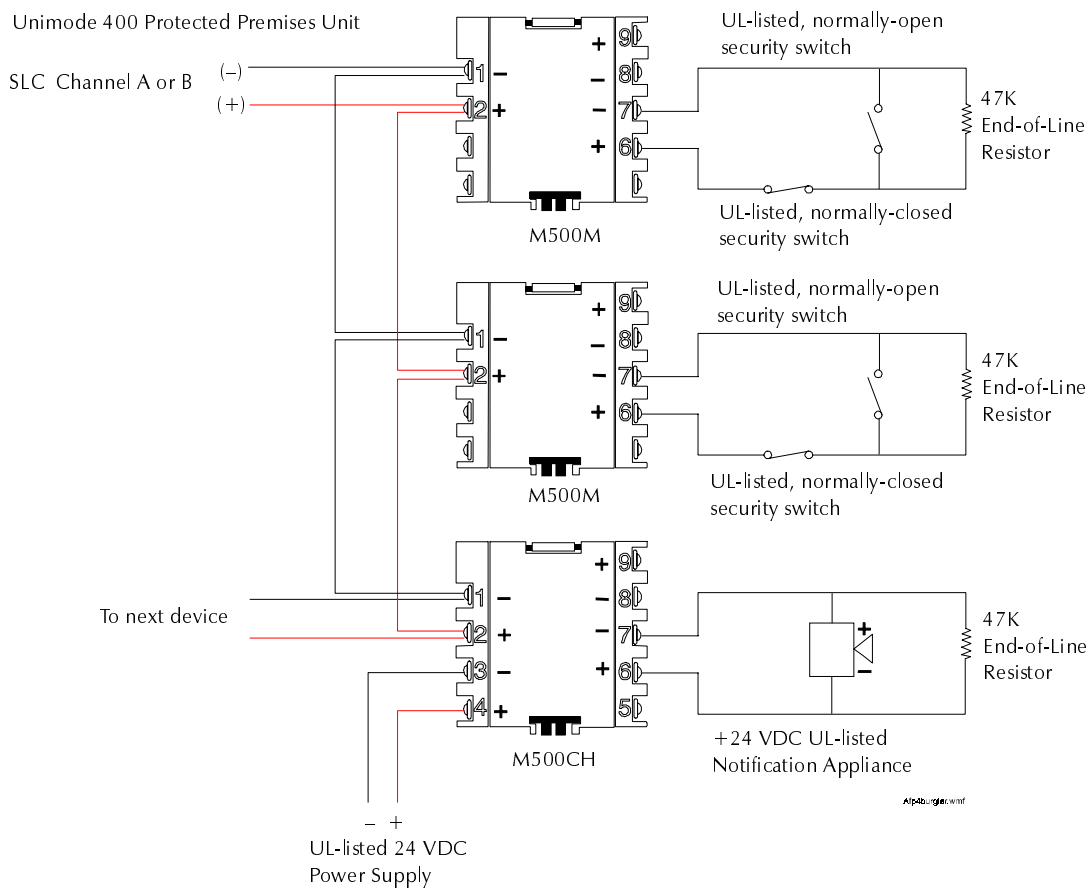

Figure 5-9 Wiring Diagram for Proprietary Security Alarm Applications

Universal Zone Coder (ADT-UZC-256)

ADT-UZC-256 Description

The ADT-UZC-256 board is used for zone coding, providing up to 256 software zone codes. The ADT-UZC-256 monitors system status through the CPU EIA-485 annunciator port and outputs pre-programmed codes in response to signals it receives. This section contains descriptions of the ADT-UZC-256 board. For instructions for installing the ADT-UZC-256, refer to Section 2, Installation. For additional information, refer to the ADT-UZC-256 manual.

ADT-UZC-256 Connectors and Indicators

Figure 5-10 shows the connections and indicators on the ADT-UZC-256 board:

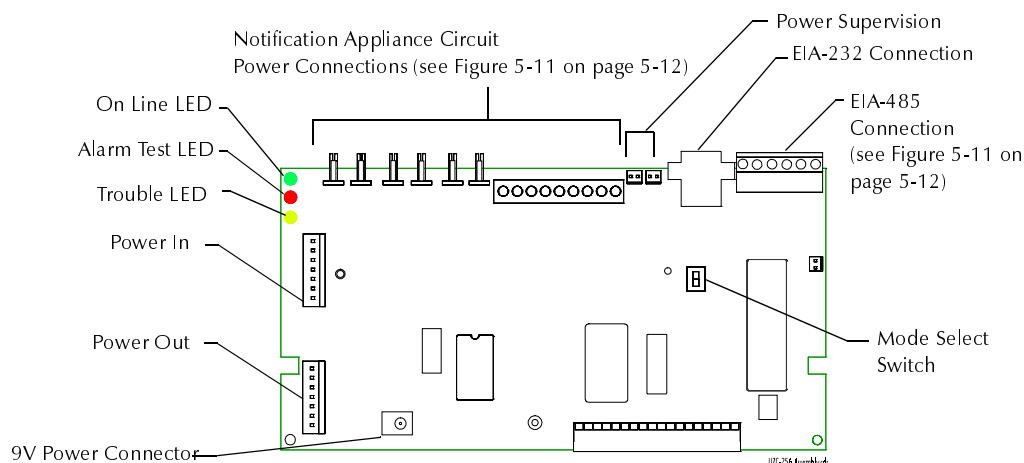

Figure 5-10 ADT-UZC-256 Board Connectors and Indicators

Table 5-6 contains descriptions of the components shown in Figure 5-10.

Item	Description
Trouble LED	Yellow LED lights when one or more trouble conditions occur.
Alarm Test LED	A red LED that lights according to the main coded output.
On Line LED	A green LED that blinks during communication with the master control panel.
Notification Appliance Circuits	Power connections for NAC outputs.
Power Out	Output for providing power to the next device in power chain.
Power In	Provides main connection to power supply. (Use a power-limited power supply.)
9V Power Connector	Input for 9-volt power for remote ADT-UZC-256 programming.
Power Supervision	Connections for power supervision wiring.
Mode Select Switch	Switch to toggle the ADT-UZC-256 between “Normal” and “Programming” mode.
EIA-232 Connection	Female DB-9 connector for programming from an IBM-compatible computer.
EIA-485 Connection	All connections are power-limited and supervised. See Figure 5-11 on page 5-12 for terminal assignment.

Table 5-6 Descriptions of ADT-UZC-256 Components

NAC and EIA-485 Power Connections

Figure 5-11 shows the NAC and EIA-485 power connections on the ADT-UZC-256 board:

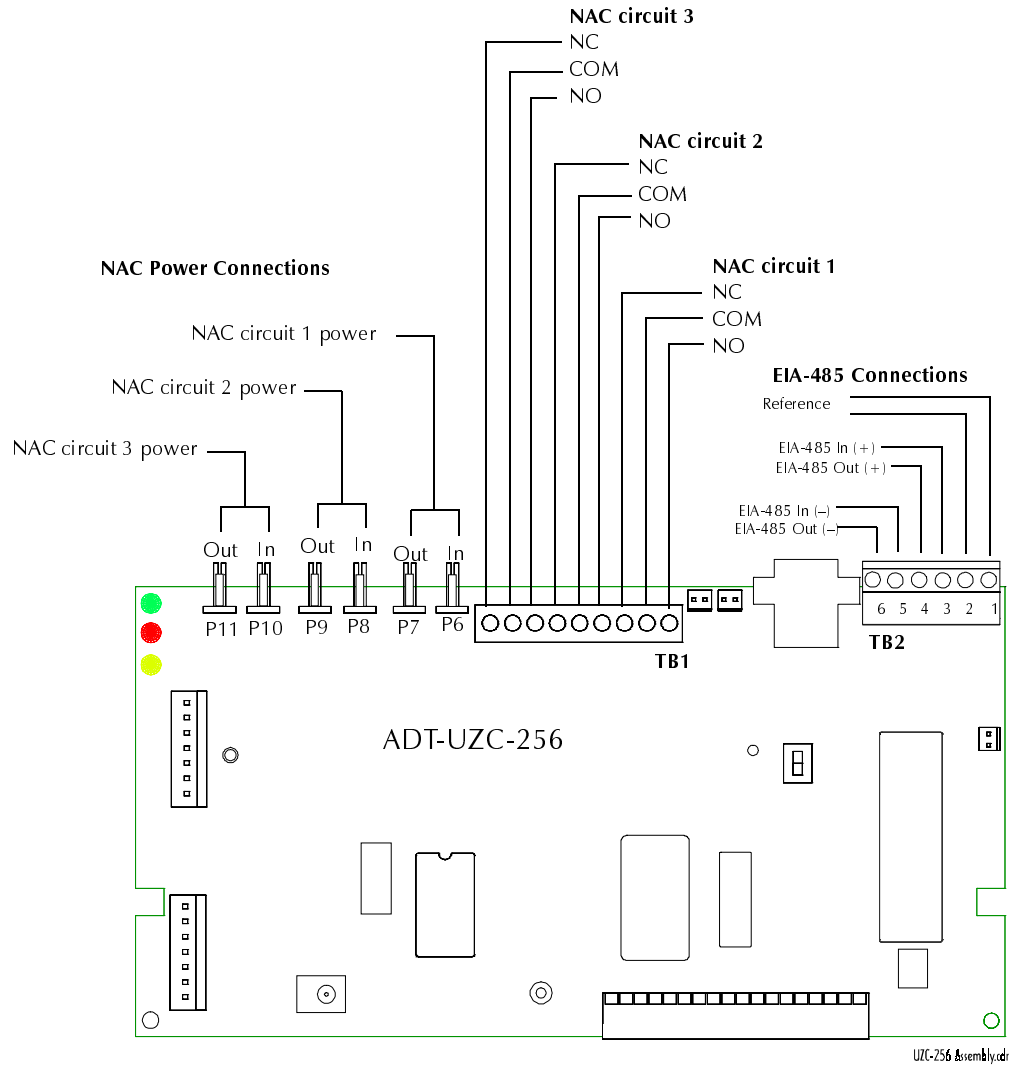

Location of NAC power Connections on ADT-UZC-256 board (see Figure 5-10 on page 5-11)

Location of EIA-485 power Connections on ADT-UZC-256 board (see Figure 5-10 on page 5-11)

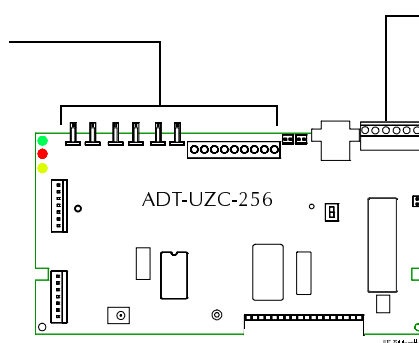

Figure 5-11 ADT-UZC-256 EIA-485 and NAC Power Connections

ADT-UZC-256 Electrical Connections

To connect the ADT-UZC-256 to the CPU, follow these steps:

1. Connect the main power harness (PN 75100, provided with the ADT-UZC-256) from MPS-400 connector J1 to ADT-UZC-256 connector P2.
2. Connect the EIA-485 ACS annunciator port as follows:
 CPU, TB4-1 to ADT-UZC-256 TB2-3
 CPU, TB4-2 to ADT-UZC-256 TB2-5
 (ADT-UZC-256 terminals are numbered from right to left.)

Note: Refer to Device Compatibility Document A15378 for compatible relays and devices.

Wiring Diagram

Figure 5-12 shows typical connections between the ADT-UZC-256 and NACs:

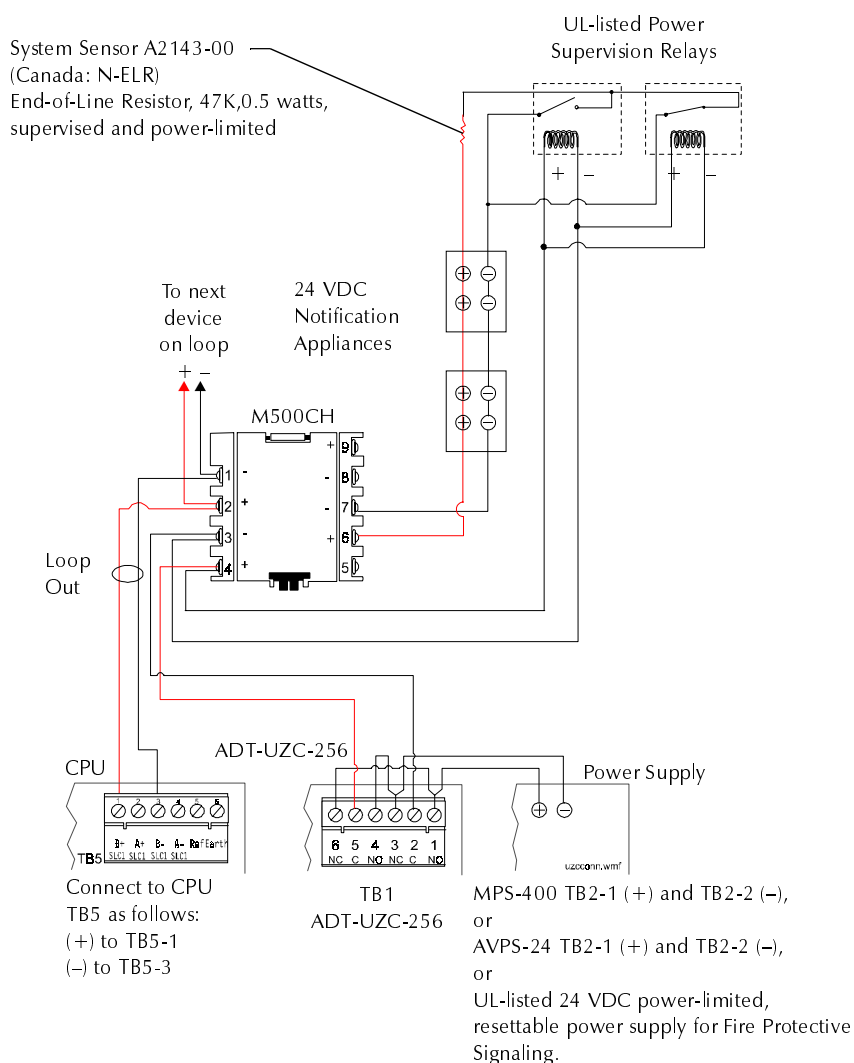

Figure 5-12 ADT-UZC-256 Connections to M500CH Modules

Wiring 12 Zone-Coded NACs

This section contains information for wiring ADT-UZC-256 modules for 12 zone-coded NACs. Table 5-7 contains a list of connections between panel modules and the ADT-UZC-256. (All cables are PN 71091, except cable PN 71093 between the MPS-400 and the ADT-UZC-256.) Make sure to mate all connectors (except MPS-400, J3) as shown in Figure 5-13.

ADT-UZC-256	Connector	Connects to...
CKT #1	P6 P7 TB1-1, TB1-2, TB1-3	AVPS-24 #1, P3 ICM-4, J5 No connections
CKT #2	P8 P9 TB1-4, TB1-5, TB1-6	AVPS-24 #2, P3 ICE-4, J5 No connections
CKT #3	TB1-8 TB1-9 TB1-7, P10, P11	MPS-400, J3 (black wire) MPS-400, J3 No connections

Table 5-7 Connection Table for 12 Zone-Coded NACs

Figure 5-13 shows a simplified block diagram wiring modules for 12 zone-coded NACs:

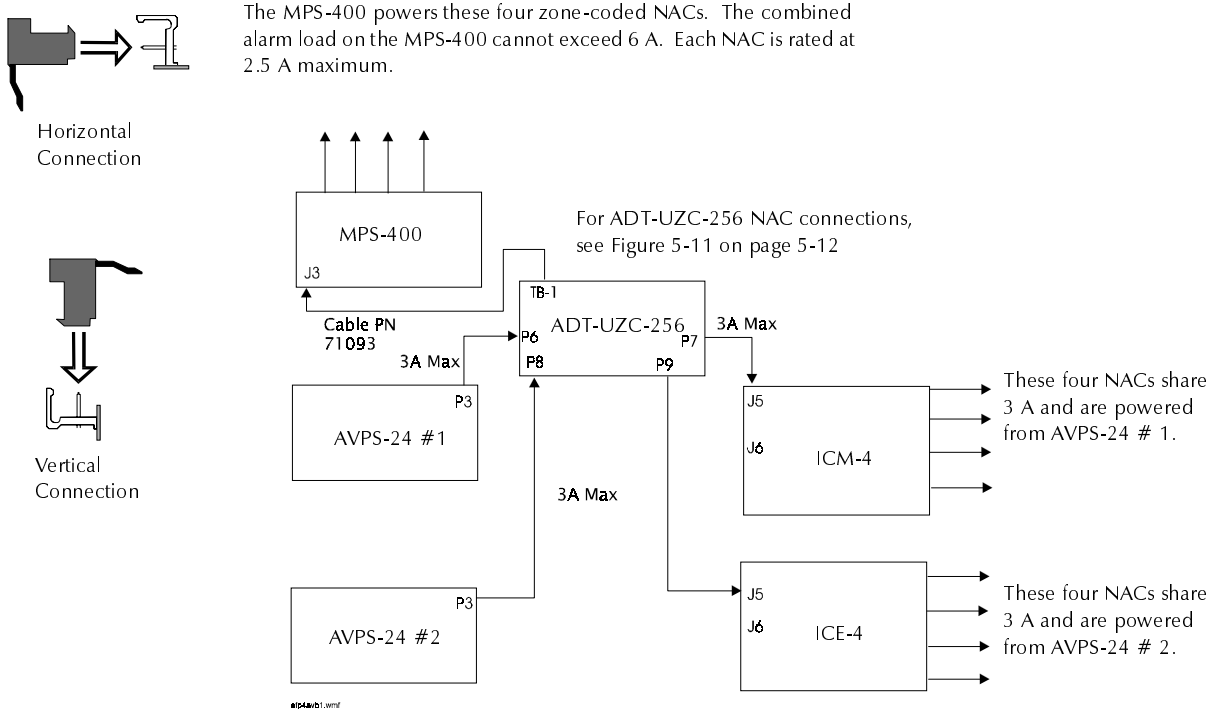

Figure 5-13 Typical Wiring for 12 Zone-Coded NACs

Wiring 20 Zone-Coded NACs

This section contains information for wiring ADT-UZC-256 modules for 20 zone-coded NACs. Table 5-8 contains a list of connections between the panel modules and the ADT-UZC-256. (All cables are PN 71091, except cable PN 71093 between the MPS-400 and the ADT-UZC-256.). Make sure to mate all connectors (except MPS-400, J3) as shown in Figure 5-14.

ADT-UZC-256	Connector	Connects to...
CKT #1	P6	AVPS-24 #1, P3
	P7	ICM-4, J5
	TB1-1, TB1-2, TB1-3	No connections
CKT #2	P8	AVPS-24 #2, P3
	P9	ICM-4, J5
	TB1-4, TB1-5, TB1-6	No connections
CKT #3	TB1-8	MPS-400, J3 (black wire)
	TB1-9	MPS-400, J3
	TB1-7, P10, P11	No connections

Table 5-8 Connection Table for 20 Zone-Coded NACs

Figure 5-14 shows a simplified block diagram wiring modules for 20 zone-coded NACs:

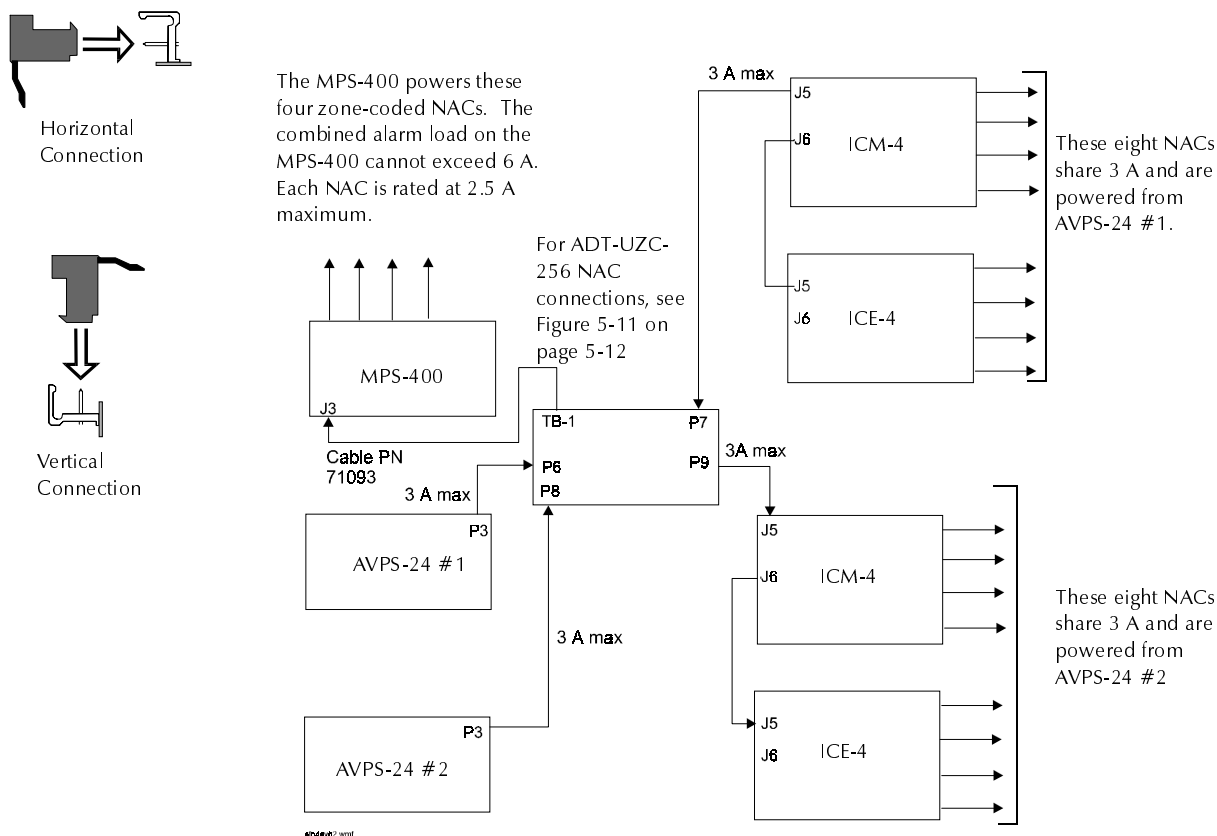

Figure 5-14 Typical Wiring for 20 Zone-Coded NACs

Releasing Applications

Overview

This control panel can be used for agent release or preaction/deluge control applications. When used with compatible, listed actuating and initiating devices, the control panel meets the requirements of these NFPA standards:

Standard	Covers
NFPA 12	CO2 Extinguishing Systems
NFPA 12A	Halon 1301 Extinguishing Systems
NFPA 12B	Halon 1211 Extinguishing Systems
NFPA 13	Sprinkler Systems
NFPA 15	Water Spray Systems
NFPA 16	Foam-Water Deluge and Foam-water Spray Systems
NFPA 17	Dry Chemical Extinguishing Systems
NFPA 17A	Wet Chemical Extinguishing Systems
NFPA 2001	Clean Agent Fire Extinguishing Systems

Table 5-9 NFPA Standards for Releasing Applications

Programming Releasing Applications

The control panel supports a maximum of ten releasing areas. You can divide the releasing circuits among the MPS-400 releasing outputs, the ICM-4, ICE-4, and M500CH modules. For more information, refer to the Unimode 400 Programming manual.

Wiring for Releasing Applications

Table 5-10 contains references to wiring diagrams for releasing applications:

To connect...	Refer to...
A releasing device to the MPS-400	"Connecting a Releasing Device to the MPS-400" on page 5-17.
A Releasing Device to an ICM-4/ICE-4	"Connecting a Releasing Device to an ICM-4/ICE-4 Module" on page 5-18.
A releasing device to an M500CH Module.	"Connecting a Releasing Device to an M500CH Module" on page 5-19.
An N-ARA-10 Agent Release-Abort Station.	"Connecting an N-ARA-10 Agent Release-Abort Station" on page 5-20.
A combination waterflow/supervisory valve monitor	"Installing a Combination Waterflow/Supervisory Valve Monitor" on page 5-21.

Table 5-10 Wiring Diagrams for Releasing Applications

Connecting a Releasing Device to the MPS-400

Overview

When connecting a releasing device to an MPS-400, note the following:

1. The control panel provides four NAC/Releasing Circuits (Style Y or Z). Each circuit can provide 2.5 A. Total current drawn from the MPS-400 cannot exceed 6 A (see Table G-2 on page G-3). Use UL-listed 24 VDC appliances only.
2. Circuits are supervised and power-limited. For more information, refer to the Device Compatibility Document.
3. For NFPA 13 and 15 applications, disable the Soak Timer (Soak=0000); for NFPA 16 applications, set the Soak Timer (0600-0900 seconds). Refer to the Unimode 400 Programming Manual for instructions on setting the Soak Timer.
4. In applications not requiring power-limited circuits – a) End-of-Line devices (PN REL-2.2K) are not required; however, the releasing device circuit is not supervised against shorts; b) Limited energy cable cannot be used for wiring of a releasing device circuit; c) Maintain a 0.25 inch spacing between the releasing circuit device wiring and any power-limited circuit wiring; and d) Program the releasing circuit for type code RELEASE CKT.

Typical Connections

Figure 5-15 shows typical connections for wiring a releasing device to an MPS-400:

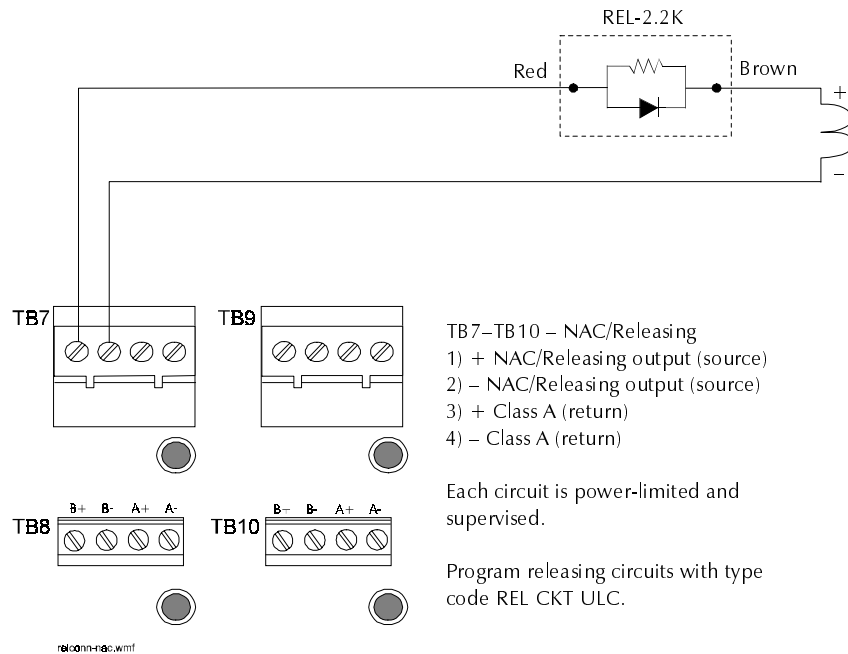

Figure 5-15 Typical Connection of a Releasing Device to the MPS-400

Connecting a Releasing Device to an ICM-4/ICE-4 Module

Overview

When connecting a releasing device to an ICM-4 or ICE-4 module, note the following:

1. The ICM-4 and ICE-4 provide four NAC/Releasing Circuits (Style Y or Z). Each circuit can provide 3 A of current. Make sure to keep total system current within the limits of the power supply. Use UL-listed 24 VDC appliances only.
2. Circuits are supervised and power-limited. For more information, refer to the Device Compatibility Document.
3. For NFPA 13 and 15 applications, disable the Soak Timer (Soak=0000); for NFPA 16 applications, set the Soak Timer (0600-0900 seconds). Refer to the Unimode 400 Programming Manual for instructions on setting the Soak Timer.
4. *In applications not requiring power-limited circuits* – a) End-of-Line devices (PN REL-4.7K) are not required; however, the releasing device circuit is not supervised against shorts; b) Limited energy cable cannot be used for wiring of a releasing device circuit; c) Maintain a 0.25 inch spacing between the releasing circuit device wiring and any power-limited circuit wiring; and d) Program the releasing circuit for type code RELEASE CKT.

Typical Connections

Figure 5-16 shows typical connections for wiring a releasing device to an ICM-4 or ICE-4 module:

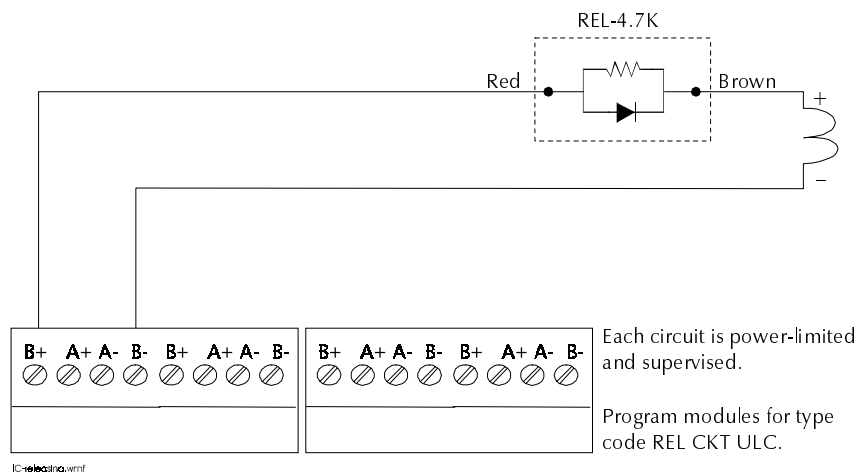

Figure 5-16 Typical Connection of Releasing Device to an ICM-4/ICE-4 Module

Connecting a Releasing Device to an M500CH Module

Overview

You can use M500CH modules for releasing circuits. Each module can control 1 A of current. Make sure to keep total system current within the limits of the power supply. You can power the M500CH from the MPS-400 or any UL-listed 24 VDC power-limited power supply for Fire Protective Signaling. For more information, refer to the Device Compatibility Document.

1. For NFPA 13 and 15 applications, disable the Soak Timer (Soak=0000); for NFPA 16 applications, set the Soak Timer (0600-0900 seconds). Refer to the Unimode 400 Programming Manual for instructions on setting the Soak Timer.
2. *In applications not requiring power-limited circuits* – a) End-of-Line devices (PN REL-47K) are not required; however, the releasing device circuit is not supervised against shorts; b) limited energy cable cannot be used for wiring of a releasing device circuit; c) Maintain a 0.25 inch spacing between the releasing circuit device wiring and any power-limited circuit wiring; and d) Program the releasing circuit for type code RELEASE CKT.
3. Each circuit is power-limited and supervised.
4. Program the M500CH for type code REL CKT ULC.

Typical Connections

Figure 5-17 shows typical connections for wiring a releasing device to an M500CH module:

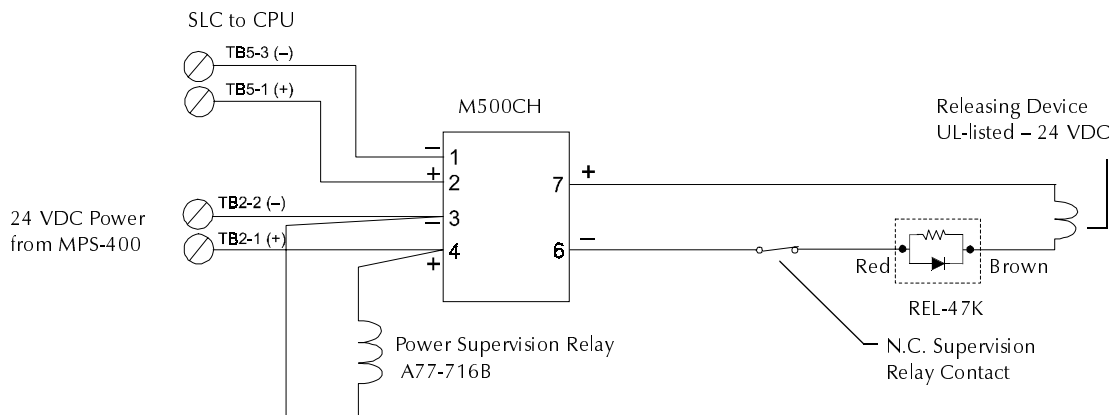

Figure 5-17 Typical Connection of a 24 VDC Releasing Device to an M500CH Module

Connecting an N-ARA-10 Agent Release-Abort Station

Overview

When connecting an N-ARA-10, note the following:

1. For releasing applications, use an end-of-line device (PN REL-47K) with the M500CH module. Use an end-of-line device (PN REL-4.7K) with the control panel releasing circuit (one of the four Notification Appliance Circuits).
2. All wiring for releasing circuits is supervised against open and shorts.
3. Connect the end-of-line device as shown in Figure 5-22.
4. Program the module or NAC for type code "Rel Ckt ULC."
5. For NFPA 13 and 15 applications, disable the Soak Timer (Soak=0000); for NFPA 16 applications, set the Soak Timer (0600-0900 seconds). Refer to the Unimode 400 Programming Manual for instructions on setting the Soak Timer.
6. *In applications not requiring power-limited circuits* – a) ELRs (PN REL-47K) are not required; however, the releasing device circuit is not supervised against shorts; b) Limited energy cable cannot be used for wiring of a releasing device circuit; c) Maintain a 0.25 inch spacing between the releasing circuit device wiring and any power-limited circuit wiring; and d) Program the releasing circuit for type code RELEASE CKT.

Typical Connections

Figure 5-18 shows typical connections for wiring an N-ARA-10 Agent Release-Abort Station:

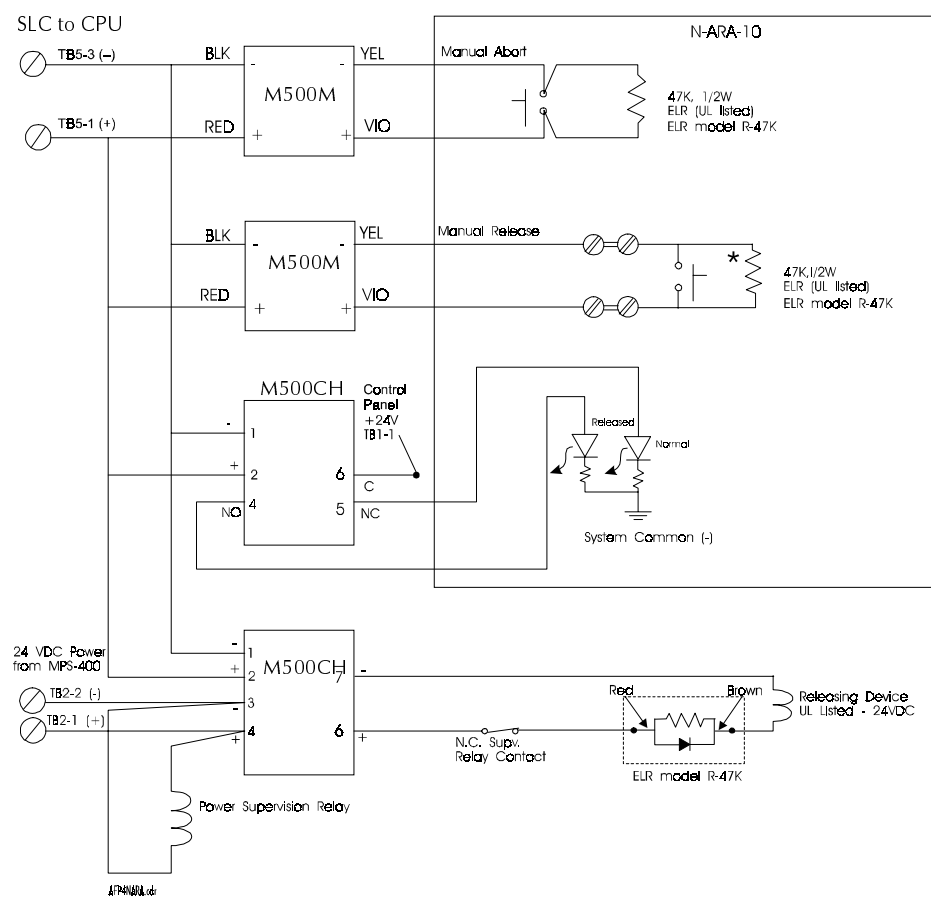

Figure 5-18 Typical Connections for an N-ARA-10 Agent Release-Abort Station

Installing a Combination Waterflow/Supervisory Valve Monitor

Overview

A Combination Waterflow/Supervisory Valve Monitor circuit allows an FACP to distinguish between a Waterflow Alarm Switch and a Waterflow Supervisory Switch installed on the same Monitor Module. Figure 5-23 shows an NFPA Style B Initiating Device Circuit (IDC) that meets requirements for a Combination Waterflow/Supervisory Valve Monitor circuit.

Typical Connections

Figure 5-19 shows typical connections for wiring a combination waterflow/supervisory valve monitor:

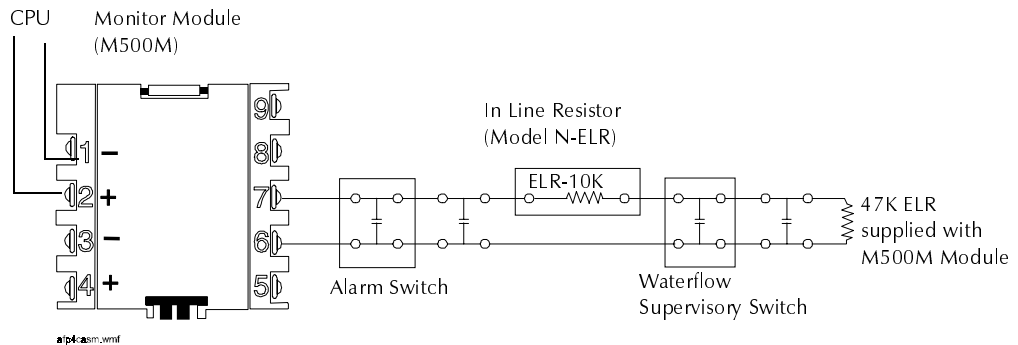

Figure 5-19 NFPA Style B Initiating Device Circuit (Supervised and Power-limited)

The following list includes requirements for the Combination Waterflow/Supervisory Valve Monitor circuit. (Refer to the Unimode 400 Programming Manual for details on programming a Monitor Module.)

1. The Waterflow Alarm Switch must connect to the Monitor Module initiating input before the In Line Resistor.
2. The Waterflow Supervisory Switch must connect to the Monitor Module initiating circuit after the In Line Resistor.
3. The Combination Waterflow/Supervisory Valve Monitor circuit only functions as a Style B (class B) circuit.
4. While a Supervisory Signal is tracking, Waterflow Alarms latch until reset.
5. Program the Monitor Module for type code SPRINKLR SYS or COMB. MONITOR (Figure 5-20).
6. Program the Monitor Module for the desired Control-by-Event (CBE).
7. A Supervisory signal does not affect the outputs listed in the Monitor Module CBE (Figure 5-20).
8. Appendix B: Wire Requirements, lists the type of wire required for an IDC.

Figure 5-20 shows a sample program screen for a waterflow application:

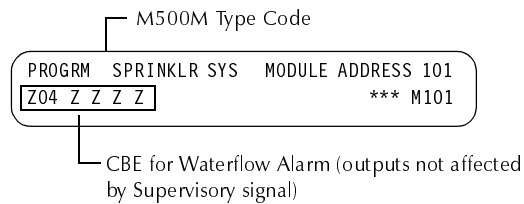

Figure 5-20 Sample Program Screen for a Waterflow Application

Notes

Appendix A: Annunciators

Overview

Appendix A contains the following information:

- Tables necessary for configuring the annunciator display; and
- Typical annunciator wiring diagrams.

Note that Appendix A contains information specific to the Unimode 400 only. For complete annunciator installation information, refer to the respective annunciator manual.

Annunciator Interfaces

The control panel provides Terminal Mode (ADT-LCD-80) and ACS Mode Interfaces that provide high speed, two-way communication link to multiple annunciators. You can locate annunciators up to 6,000 feet from the control panel.

Terminal Mode (ADT-LCD-80)

Use the Terminal Mode interface for communicating with ADT-LCD-80 annunciators operating in Terminal Mode (through TB3 on the CPU). In Terminal Mode, each ADT-LCD-80 display mirrors the Unimode 400 front panel display. Also, each ADT-LCD-80 displays the complete status of the fire alarm system and lets you do Acknowledge, Silence, and System Reset control panel functions from a remote location.

ACS Mode

Use the ACS Mode Interface (through TB4 on the CPU) for communicating with the following LED/Lamp type annunciators: ADT-ACM-16AT, AEM-16AT, ADT-ACM-32A, AEM-32A, ADT-AFM-16A, ADT-AFM-32A, ADT-AFM-16AT, ADT-LDM-32, LDM-E32, and LDM-R32. The ACS interface also communicates with the AMG-1 Audio Message Generator, the ADT-UZC-256 Universal Zone Coder, the ADT-NIB-96 Network Interface Board, the ADT-LCD-80 Annunciators operating in the ACS Mode and the ADT-ACM-8R Relay Annunciator Module.

The ADT-ACM-8R Relay Module provides relays for controlling equipment located at remote locations. The ADT-ACM-8R greatly increases the relay control capabilities of the control panel. You can assign the ADT-ACM-8R to any of the 576 panel annunciation points. Each ADT-ACM-8R module covers continuous groups of eight panel points.

The ACS Mode Interface can annunciate CPU, zone, detector, module, and circuit status. The 576 panel annunciation points are divided into nine groups of 64 points, as shown in Table A-2 through Table A-10. Each group can be assigned to one or more of the ten annunciator addresses supported by the control panel.

The control panel uses ACS annunciator addresses 1-19 without a UDACT and ACS annunciator addresses 1-10 with a UDACT. Each address can communicate with one receive/transmit device. Configure other devices on the same address as Receive Only. You can connect up to 32 devices to the ACS output, all addresses combined.

Use the ACS Mode Interface to Acknowledge, Silence, Drill, and Reset the control panel from a remote location. The ACS Mode Interface can also activate output circuits and control modules from remote locations.

Annunciator Selection Groups

Overview

The control panel's annunciation points are divided into eleven ACS selection groups as follows:

- Nine predefined ACS selection groups (1-9), each containing 64 points.
- Two user-defined ACS selection groups (Special Annunciators A and B) that lets a system designer assign detectors, modules, and zones to any annunciator point. Special Annunciator A and B selections are programmed using the Uni•Tility off-line programming utility.

Table A-1 contains a list of the eleven ACS selection groups and what an annunciator displays if a group is selected.

ACS Selection Group	Annunciator Display	Refer to...
1	CPU Status and Zones 1-56	Table A-2 on page A-3
2	Zones 57-99, NACs 1-4 and 16 special zones	Table A-3 on page A-4
3	Intelligent modules 101–164	Table A-4 on page A-5
4	Intelligent modules 201-264	Table A-5 on page A-6
5	Intelligent modules 165-196 and 265-296	Table A-6 on page A-7
6	Detectors 101–164 on SLC 1	Table A-7 on page A-8
7	Detectors 201-264 on SLC 2	Table A-8 on page A-9
8	Detectors 165-196 and 265-296	Table A-9 on page A-10
9	NAC/Panel Output Circuit modules (64 points)	Table A-10 on page A-11
A	Special Annunciator A programmed selections (see note below)	Uni•Tility on-line help
B	Special Annunciator B programmed selections (see note below)	Uni•Tility on-line help
* or 0	Annunciator not installed at address	N/A
Note: The Uni•Tility off-line programming utility is required for programming Special Annunciators A and B.		

Table A-1 ACS Selection Groups

ACS Annunciator Selection Group 1

ACS Point Number	Point Type	Red LED Indicates	Yellow LED Indicates	Switch Function	Comments
1	Input	System Alarm	System Trouble	Acknowledge	
2	Output	Not Used	Signal Silenced	Signal Silence	
3	Output	Not Used	Program Mode	System Reset	
4	Output	Not Used	Supervisory	Drill	
5	Output	NAC #1 Active	NAC Trouble	Control NAC #1	
6	Input	Not Used	PA/Maint Alert	Not Used	
7	Input	Not Used	Low Battery	Not Used	
8	Input	Not Used	AC Fail	Not Used	
9	Input	Zone 1 Active	Zone 1 Trouble	Not Used	
10	Input	Zone 2 Active	Zone 2 Trouble	Not Used	
11	Input	Zone 3 Active	Zone 3 Trouble	Not Used	
12	Input	Zone 4 Active	Zone 4 Trouble	Not Used	
13	Input	Zone 5 Active	Zone 5 Trouble	Not Used	
14	Input	Zone 6 Active	Zone 6 Trouble	Not Used	
15	Input	Zone 7 Active	Zone 7 Trouble	Not Used	
16	Input	Zone 8 Active	Zone 8 Trouble	Not Used	
17	Input	Zone 9 Active	Zone 9 Trouble	Not Used	
18	Input	Zone 10 Active	Zone 10 Trouble	Not Used	
19	Input	Zone 11 Active	Zone 11 Trouble	Not Used	
20	Input	Zone 12 Active	Zone 12 Trouble	Not Used	
21	Input	Zone 13 Active	Zone 13 Trouble	Not Used	
22	Input	Zone 14 Active	Zone 14 Trouble	Not Used	
23	Input	Zone 15 Active	Zone 15 Trouble	Not Used	
24	Input	Zone 16 Active	Zone 16 Trouble	Not Used	
25	Input	Zone 17 Active	Zone 17 Trouble	Not Used	
26	Input	Zone 18 Active	Zone 18 Trouble	Not Used	
27	Input	Zone 19 Active	Zone 19 Trouble	Not Used	
28	Input	Zone 20 Active	Zone 20 Trouble	Not Used	
29	Input	Zone 21 Active	Zone 21 Trouble	Not Used	
30	Input	Zone 22 Active	Zone 22 Trouble	Not Used	
31	Input	Zone 23 Active	Zone 23 Trouble	Not Used	
32	Input	Zone 24 Active	Zone 24 Trouble	Not Used	
33	Input	Zone 25 Active	Zone 25 Trouble	Not Used	
34	Input	Zone 26 Active	Zone 26 Trouble	Not Used	
35	Input	Zone 27 Active	Zone 27 Trouble	Not Used	
36	Input	Zone 28 Active	Zone 28 Trouble	Not Used	
37	Input	Zone 29 Active	Zone 29 Trouble	Not Used	
38	Input	Zone 30 Active	Zone 30 Trouble	Not Used	
39	Input	Zone 31 Active	Zone 31 Trouble	Not Used	
40	Input	Zone 32 Active	Zone 32 Trouble	Not Used	
41	Input	Zone 33 Active	Zone 33 Trouble	Not Used	
42	Input	Zone 34 Active	Zone 34 Trouble	Not Used	
43	Input	Zone 35 Active	Zone 35 Trouble	Not Used	
44	Input	Zone 36 Active	Zone 36 Trouble	Not Used	
45	Input	Zone 37 Active	Zone 37 Trouble	Not Used	
46	Input	Zone 38 Active	Zone 38 Trouble	Not Used	
47	Input	Zone 39 Active	Zone 39 Trouble	Not Used	
48	Input	Zone 40 Active	Zone 40 Trouble	Not Used	
49	Input	Zone 41 Active	Zone 41 Trouble	Not Used	
50	Input	Zone 42 Active	Zone 42 Trouble	Not Used	
51	Input	Zone 43 Active	Zone 43 Trouble	Not Used	
52	Input	Zone 44 Active	Zone 44 Trouble	Not Used	
53	Input	Zone 45 Active	Zone 45 Trouble	Not Used	
54	Input	Zone 46 Active	Zone 46 Trouble	Not Used	
55	Input	Zone 47 Active	Zone 47 Trouble	Not Used	
56	Input	Zone 48 Active	Zone 48 Trouble	Not Used	
57	Input	Zone 49 Active	Zone 49 Trouble	Not Used	
58	Input	Zone 50 Active	Zone 50 Trouble	Not Used	
59	Input	Zone 51 Active	Zone 51 Trouble	Not Used	
60	Input	Zone 52 Active	Zone 52 Trouble	Not Used	
61	Input	Zone 53 Active	Zone 53 Trouble	Not Used	
62	Input	Zone 54 Active	Zone 54 Trouble	Not Used	
63	Input	Zone 55 Active	Zone 55 Trouble	Not Used	
64	Input	Zone 56 Active	Zone 56 Trouble	Not Used	

Table A-2 ACS Annunciator Selection Group 1

ACS Annunciator Selection Group 2

ACS Point Number	Point Type	Red LED Indicates	Yellow LED Indicates	Switch Function	Comments
1	Input	Zone 57 Active	Zone 57 Trouble	Not Used	
2	Input	Zone 58 Active	Zone 58 Trouble	Not Used	
3	Input	Zone 59 Active	Zone 59 Trouble	Not Used	
4	Input	Zone 60 Active	Zone 60 Trouble	Not Used	
5	Input	Zone 61 Active	Zone 61 Trouble	Not Used	
6	Input	Zone 62 Active	Zone 62 Trouble	Not Used	
7	Input	Zone 63 Active	Zone 63 Trouble	Not Used	
8	Input	Zone 64 Active	Zone 64 Trouble	Not Used	
9	Input	Zone 65 Active	Zone 65 Trouble	Not Used	
10	Input	Zone 66 Active	Zone 66 Trouble	Not Used	
11	Input	Zone 67 Active	Zone 67 Trouble	Not Used	
12	Input	Zone 68 Active	Zone 68 Trouble	Not Used	
13	Input	Zone 69 Active	Zone 69 Trouble	Not Used	
14	Input	Zone 70 Active	Zone 70 Trouble	Not Used	
15	Input	Zone 71 Active	Zone 71 Trouble	Not Used	
16	Input	Zone 72 Active	Zone 72 Trouble	Not Used	
17	Input	Zone 73 Active	Zone 73 Trouble	Not Used	
18	Input	Zone 74 Active	Zone 74 Trouble	Not Used	
19	Input	Zone 75 Active	Zone 75 Trouble	Not Used	
20	Input	Zone 76 Active	Zone 76 Trouble	Not Used	
21	Input	Zone 77 Active	Zone 77 Trouble	Not Used	
22	Input	Zone 78 Active	Zone 78 Trouble	Not Used	
23	Input	Zone 79 Active	Zone 79 Trouble	Not Used	
24	Input	Zone 80 Active	Zone 80 Trouble	Not Used	
25	Input	Zone 81 Active	Zone 81 Trouble	Not Used	
26	Input	Zone 82 Active	Zone 82 Trouble	Not Used	
27	Input	Zone 83 Active	Zone 83 Trouble	Not Used	
28	Input	Zone 84 Active	Zone 84 Trouble	Not Used	
29	Input	Zone 85 Active	Zone 85 Trouble	Not Used	
30	Input	Zone 86 Active	Zone 86 Trouble	Not Used	
31	Input	Zone 87 Active	Zone 87 Trouble	Not Used	
32	Input	Zone 88 Active	Zone 88 Trouble	Not Used	
33	Input	Zone 89 Active	Zone 89 Trouble	Not Used	
34	Input	Zone 90 Active	Zone 90 Trouble	Not Used	
35	Input	Zone 91 Active	Zone 91 Trouble	Not Used	
36	Input	Zone 92 Active	Zone 92 Trouble	Not Used	
37	Input	Zone 93 Active	Zone 93 Trouble	Not Used	
38	Input	Zone 94 Active	Zone 94 Trouble	Not Used	
39	Input	Zone 95 Active	Zone 95 Trouble	Not Used	
40	Input	Zone 96 Active	Zone 96 Trouble	Not Used	
41	Input	Zone 97 Active	Zone 97 Trouble	Not Used	
42	Input	Zone 98 Active	Zone 98 Trouble	Not Used	
43	Input	Zone 99 Active	Zone 99 Trouble	Not Used	
44	Output	Zone F1 Active	Zone F1 Trouble	Not Used	
45	Output	Zone F2 Active	Zone F2 Trouble	Not Used	
46	Output	Zone F3 Active	Zone F3 Trouble	Not Used	
47	Output	Zone F4 Active	Zone F4 Trouble	Not Used	
48	Output	Zone F5 Active	Zone F5 Trouble	Not Used	
49	Output	Zone F6 Active	Zone F6 Trouble	Not Used	
50	Output	Zone F7 Active	Zone F7 Trouble	Not Used	
51	Output	Zone F8 Active	Zone F8 Trouble	Not Used	
52	Output	Zone F9 Active	Zone F9 Trouble	Not Used	
53	Release Ckt # 0	Zone R0 Active	Zone R1 Trouble	Not Used	
54	Release Ckt # 1	Zone R1 Active	Zone R2 Trouble	Not Used	
55	Release Ckt # 2	Zone R2 Active	Zone R3 Trouble	Not Used	
56	Release Ckt # 3	Zone R3 Active	Zone R4 Trouble	Not Used	
57	Release Ckt # 4	Zone R4 Active	Zone R5 Trouble	Not Used	
58	Release Ckt # 5	Zone R5 Active	Zone R6 Trouble	Not Used	
59	Release Ckt # 6	Zone R6 Active	Zone R7 Trouble	Not Used	
60	Release Ckt # 7	Zone R7 Active	Zone R8 Trouble	Not Used	
61	NAC Output	NAC B01 Active	NAC B01 Trouble	Controls NAC B01	
62	NAC Output	NAC B02 Active	NAC B02 Trouble	Controls NAC B02	
63	NAC Output	NAC B03 Active	NAC B03 Trouble	Controls NAC B03	
64	NAC Output	NAC B04 Active	NAC B04 Trouble	Controls NAC B04	

Table A-3 ACS Annunciator Selection Group 2

ACS Annunciator Selection Group 5

ACS Point Number	Point Type	Red LED Indicates	Yellow LED Indicates	Switch Function	Comments
1	Input or Output	Module 165 Active	Module 165 Trouble	Controls Output Module	
2	Input or Output	Module 166 Active	Module 166 Trouble	Controls Output Module	
3	Input or Output	Module 167 Active	Module 167 Trouble	Controls Output Module	
4	Input or Output	Module 168 Active	Module 168 Trouble	Controls Output Module	
5	Input or Output	Module 169 Active	Module 169 Trouble	Controls Output Module	
6	Input or Output	Module 170 Active	Module 170 Trouble	Controls Output Module	
7	Input or Output	Module 171 Active	Module 171 Trouble	Controls Output Module	
8	Input or Output	Module 172 Active	Module 172 Trouble	Controls Output Module	
9	Input or Output	Module 173 Active	Module 173 Trouble	Controls Output Module	
10	Input or Output	Module 174 Active	Module 174 Trouble	Controls Output Module	
11	Input or Output	Module 175 Active	Module 175 Trouble	Controls Output Module	
12	Input or Output	Module 176 Active	Module 176 Trouble	Controls Output Module	
13	Input or Output	Module 177 Active	Module 177 Trouble	Controls Output Module	
14	Input or Output	Module 178 Active	Module 178 Trouble	Controls Output Module	
15	Input or Output	Module 179 Active	Module 179 Trouble	Controls Output Module	
16	Input or Output	Module 180 Active	Module 180 Trouble	Controls Output Module	
17	Input or Output	Module 181 Active	Module 181 Trouble	Controls Output Module	
18	Input or Output	Module 182 Active	Module 182 Trouble	Controls Output Module	
19	Input or Output	Module 183 Active	Module 183 Trouble	Controls Output Module	
20	Input or Output	Module 184 Active	Module 184 Trouble	Controls Output Module	
21	Input or Output	Module 185 Active	Module 185 Trouble	Controls Output Module	
22	Input or Output	Module 186 Active	Module 186 Trouble	Controls Output Module	
23	Input or Output	Module 187 Active	Module 187 Trouble	Controls Output Module	
24	Input or Output	Module 188 Active	Module 188 Trouble	Controls Output Module	
25	Input or Output	Module 189 Active	Module 189 Trouble	Controls Output Module	
26	Input or Output	Module 190 Active	Module 190 Trouble	Controls Output Module	
27	Input or Output	Module 191 Active	Module 191 Trouble	Controls Output Module	
28	Input or Output	Module 192 Active	Module 192 Trouble	Controls Output Module	
29	Input or Output	Module 193 Active	Module 193 Trouble	Controls Output Module	
30	Input or Output	Module 194 Active	Module 194 Trouble	Controls Output Module	
31	Input or Output	Module 195 Active	Module 195 Trouble	Controls Output Module	
32	Input or Output	Module 196 Active	Module 196 Trouble	Controls Output Module	
33	Input or Output	Module 265 Active	Module 265 Trouble	Controls Output Module	
34	Input or Output	Module 266 Active	Module 266 Trouble	Controls Output Module	
35	Input or Output	Module 267 Active	Module 267 Trouble	Controls Output Module	
36	Input or Output	Module 268 Active	Module 268 Trouble	Controls Output Module	
37	Input or Output	Module 269 Active	Module 269 Trouble	Controls Output Module	
38	Input or Output	Module 270 Active	Module 270 Trouble	Controls Output Module	
39	Input or Output	Module 271 Active	Module 271 Trouble	Controls Output Module	
40	Input or Output	Module 272 Active	Module 272 Trouble	Controls Output Module	
41	Input or Output	Module 273 Active	Module 273 Trouble	Controls Output Module	
42	Input or Output	Module 274 Active	Module 274 Trouble	Controls Output Module	
43	Input or Output	Module 275 Active	Module 275 Trouble	Controls Output Module	
44	Input or Output	Module 276 Active	Module 276 Trouble	Controls Output Module	
45	Input or Output	Module 277 Active	Module 277 Trouble	Controls Output Module	
46	Input or Output	Module 278 Active	Module 278 Trouble	Controls Output Module	
47	Input or Output	Module 279 Active	Module 279 Trouble	Controls Output Module	
48	Input or Output	Module 280 Active	Module 280 Trouble	Controls Output Module	
49	Input or Output	Module 281 Active	Module 281 Trouble	Controls Output Module	
50	Input or Output	Module 282 Active	Module 282 Trouble	Controls Output Module	
51	Input or Output	Module 283 Active	Module 283 Trouble	Controls Output Module	
52	Input or Output	Module 284 Active	Module 284 Trouble	Controls Output Module	
53	Input or Output	Module 285 Active	Module 285 Trouble	Controls Output Module	
54	Input or Output	Module 286 Active	Module 286 Trouble	Controls Output Module	
55	Input or Output	Module 187 Active	Module 287 Trouble	Controls Output Module	
56	Input or Output	Module 288 Active	Module 288 Trouble	Controls Output Module	
57	Input or Output	Module 289 Active	Module 289 Trouble	Controls Output Module	
58	Input or Output	Module 290 Active	Module 290 Trouble	Controls Output Module	
59	Input or Output	Module 291 Active	Module 291 Trouble	Controls Output Module	
60	Input or Output	Module 292 Active	Module 292 Trouble	Controls Output Module	
61	Input or Output	Module 293 Active	Module 293 Trouble	Controls Output Module	
62	Input or Output	Module 294 Active	Module 294 Trouble	Controls Output Module	
63	Input or Output	Module 295 Active	Module 295 Trouble	Controls Output Module	
64	Input or Output	Module 296 Active	Module 296 Trouble	Controls Output Module	

Table A-6 ACS Annunciator Selection Group 5

ACS Annunciator Selection Group 6

ACS Point Number	Point Type	Red LED Indicates	Yellow LED Indicates	Switch Function	Comments
1	Input	Detector 101 Alarm	Detector 101 Trouble	Not Used	
2	Input	Detector 102 Alarm	Detector 102 Trouble	Not Used	
3	Input	Detector 103 Alarm	Detector 103 Trouble	Not Used	
4	Input	Detector 104 Alarm	Detector 104 Trouble	Not Used	
5	Input	Detector 105 Alarm	Detector 105 Trouble	Not Used	
6	Input	Detector 106 Alarm	Detector 106 Trouble	Not Used	
7	Input	Detector 107 Alarm	Detector 107 Trouble	Not Used	
8	Input	Detector 108 Alarm	Detector 108 Trouble	Not Used	
9	Input	Detector 109 Alarm	Detector 109 Trouble	Not Used	
10	Input	Detector 110 Alarm	Detector 110 Trouble	Not Used	
11	Input	Detector 111 Alarm	Detector 111 Trouble	Not Used	
12	Input	Detector 112 Alarm	Detector 112 Trouble	Not Used	
13	Input	Detector 113 Alarm	Detector 113 Trouble	Not Used	
14	Input	Detector 114 Alarm	Detector 114 Trouble	Not Used	
15	Input	Detector 115 Alarm	Detector 115 Trouble	Not Used	
16	Input	Detector 116 Alarm	Detector 116 Trouble	Not Used	
17	Input	Detector 117 Alarm	Detector 117 Trouble	Not Used	
18	Input	Detector 118 Alarm	Detector 118 Trouble	Not Used	
19	Input	Detector 119 Alarm	Detector 119 Trouble	Not Used	
20	Input	Detector 120 Alarm	Detector 120 Trouble	Not Used	
21	Input	Detector 121 Alarm	Detector 121 Trouble	Not Used	
22	Input	Detector 122 Alarm	Detector 122 Trouble	Not Used	
23	Input	Detector 123 Alarm	Detector 123 Trouble	Not Used	
24	Input	Detector 124 Alarm	Detector 124 Trouble	Not Used	
25	Input	Detector 125 Alarm	Detector 125 Trouble	Not Used	
26	Input	Detector 126 Alarm	Detector 126 Trouble	Not Used	
27	Input	Detector 127 Alarm	Detector 127 Trouble	Not Used	
28	Input	Detector 128 Alarm	Detector 128 Trouble	Not Used	
29	Input	Detector 129 Alarm	Detector 129 Trouble	Not Used	
30	Input	Detector 130 Alarm	Detector 130 Trouble	Not Used	
31	Input	Detector 131 Alarm	Detector 131 Trouble	Not Used	
32	Input	Detector 132 Alarm	Detector 132 Trouble	Not Used	
33	Input	Detector 133 Alarm	Detector 133 Trouble	Not Used	
34	Input	Detector 134 Alarm	Detector 134 Trouble	Not Used	
35	Input	Detector 135 Alarm	Detector 135 Trouble	Not Used	
36	Input	Detector 136 Alarm	Detector 136 Trouble	Not Used	
37	Input	Detector 137 Alarm	Detector 137 Trouble	Not Used	
38	Input	Detector 138 Alarm	Detector 138 Trouble	Not Used	
39	Input	Detector 139 Alarm	Detector 139 Trouble	Not Used	
40	Input	Detector 140 Alarm	Detector 140 Trouble	Not Used	
41	Input	Detector 141 Alarm	Detector 141 Trouble	Not Used	
42	Input	Detector 142 Alarm	Detector 142 Trouble	Not Used	
43	Input	Detector 143 Alarm	Detector 143 Trouble	Not Used	
44	Input	Detector 144 Alarm	Detector 144 Trouble	Not Used	
45	Input	Detector 145 Alarm	Detector 145 Trouble	Not Used	
46	Input	Detector 146 Alarm	Detector 146 Trouble	Not Used	
47	Input	Detector 147 Alarm	Detector 147 Trouble	Not Used	
48	Input	Detector 148 Alarm	Detector 148 Trouble	Not Used	
49	Input	Detector 149 Alarm	Detector 149 Trouble	Not Used	
50	Input	Detector 150 Alarm	Detector 150 Trouble	Not Used	
51	Input	Detector 151 Alarm	Detector 151 Trouble	Not Used	
52	Input	Detector 152 Alarm	Detector 152 Trouble	Not Used	
53	Input	Detector 153 Alarm	Detector 153 Trouble	Not Used	
54	Input	Detector 154 Alarm	Detector 154 Trouble	Not Used	
55	Input	Detector 155 Alarm	Detector 155 Trouble	Not Used	
56	Input	Detector 156 Alarm	Detector 156 Trouble	Not Used	
57	Input	Detector 157 Alarm	Detector 157 Trouble	Not Used	
58	Input	Detector 158 Alarm	Detector 158 Trouble	Not Used	
59	Input	Detector 159 Alarm	Detector 159 Trouble	Not Used	
60	Input	Detector 160 Alarm	Detector 160 Trouble	Not Used	
61	Input	Detector 161 Alarm	Detector 161 Trouble	Not Used	
62	Input	Detector 162 Alarm	Detector 162 Trouble	Not Used	
63	Input	Detector 163 Alarm	Detector 163 Trouble	Not Used	
64	Input	Detector 164 Alarm	Detector 164 Trouble	Not Used	

Table A-7 ACS Annunciator Selection Group 6

ACS Annunciator Selection Group 7

ACS Point Number	Point Type	Red LED Indicates	Yellow LED Indicates	Switch Function	Comments
1	Input	Detector 201 Alarm	Detector 201 Trouble	Not Used	
2	Input	Detector 202 Alarm	Detector 202 Trouble	Not Used	
3	Input	Detector 203 Alarm	Detector 203 Trouble	Not Used	
4	Input	Detector 204 Alarm	Detector 204 Trouble	Not Used	
5	Input	Detector 205 Alarm	Detector 205 Trouble	Not Used	
6	Input	Detector 206 Alarm	Detector 206 Trouble	Not Used	
7	Input	Detector 207 Alarm	Detector 207 Trouble	Not Used	
8	Input	Detector 208 Alarm	Detector 208 Trouble	Not Used	
9	Input	Detector 209 Alarm	Detector 209 Trouble	Not Used	
10	Input	Detector 210 Alarm	Detector 210 Trouble	Not Used	
11	Input	Detector 211 Alarm	Detector 211 Trouble	Not Used	
12	Input	Detector 212 Alarm	Detector 212 Trouble	Not Used	
13	Input	Detector 213 Alarm	Detector 213 Trouble	Not Used	
14	Input	Detector 214 Alarm	Detector 214 Trouble	Not Used	
15	Input	Detector 215 Alarm	Detector 215 Trouble	Not Used	
16	Input	Detector 216 Alarm	Detector 216 Trouble	Not Used	
17	Input	Detector 217 Alarm	Detector 217 Trouble	Not Used	
18	Input	Detector 218 Alarm	Detector 218 Trouble	Not Used	
19	Input	Detector 219 Alarm	Detector 219 Trouble	Not Used	
20	Input	Detector 220 Alarm	Detector 220 Trouble	Not Used	
21	Input	Detector 221 Alarm	Detector 221 Trouble	Not Used	
22	Input	Detector 222 Alarm	Detector 222 Trouble	Not Used	
23	Input	Detector 223 Alarm	Detector 223 Trouble	Not Used	
24	Input	Detector 224 Alarm	Detector 224 Trouble	Not Used	
25	Input	Detector 225 Alarm	Detector 225 Trouble	Not Used	
26	Input	Detector 226 Alarm	Detector 226 Trouble	Not Used	
27	Input	Detector 227 Alarm	Detector 227 Trouble	Not Used	
28	Input	Detector 228 Alarm	Detector 228 Trouble	Not Used	
29	Input	Detector 229 Alarm	Detector 229 Trouble	Not Used	
30	Input	Detector 230 Alarm	Detector 230 Trouble	Not Used	
31	Input	Detector 231 Alarm	Detector 231 Trouble	Not Used	
32	Input	Detector 232 Alarm	Detector 232 Trouble	Not Used	
33	Input	Detector 233 Alarm	Detector 233 Trouble	Not Used	
34	Input	Detector 234 Alarm	Detector 234 Trouble	Not Used	
35	Input	Detector 235 Alarm	Detector 235 Trouble	Not Used	
36	Input	Detector 236 Alarm	Detector 236 Trouble	Not Used	
37	Input	Detector 237 Alarm	Detector 237 Trouble	Not Used	
38	Input	Detector 238 Alarm	Detector 238 Trouble	Not Used	
39	Input	Detector 239 Alarm	Detector 239 Trouble	Not Used	
40	Input	Detector 240 Alarm	Detector 240 Trouble	Not Used	
41	Input	Detector 241 Alarm	Detector 241 Trouble	Not Used	
42	Input	Detector 242 Alarm	Detector 242 Trouble	Not Used	
43	Input	Detector 243 Alarm	Detector 243 Trouble	Not Used	
44	Input	Detector 244 Alarm	Detector 244 Trouble	Not Used	
45	Input	Detector 245 Alarm	Detector 245 Trouble	Not Used	
46	Input	Detector 246 Alarm	Detector 246 Trouble	Not Used	
47	Input	Detector 247 Alarm	Detector 247 Trouble	Not Used	
48	Input	Detector 248 Alarm	Detector 248 Trouble	Not Used	
49	Input	Detector 249 Alarm	Detector 249 Trouble	Not Used	
50	Input	Detector 250 Alarm	Detector 250 Trouble	Not Used	
51	Input	Detector 251 Alarm	Detector 251 Trouble	Not Used	
52	Input	Detector 252 Alarm	Detector 252 Trouble	Not Used	
53	Input	Detector 253 Alarm	Detector 253 Trouble	Not Used	
54	Input	Detector 254 Alarm	Detector 254 Trouble	Not Used	
55	Input	Detector 255 Alarm	Detector 255 Trouble	Not Used	
56	Input	Detector 256 Alarm	Detector 256 Trouble	Not Used	
57	Input	Detector 257 Alarm	Detector 257 Trouble	Not Used	
58	Input	Detector 258 Alarm	Detector 258 Trouble	Not Used	
59	Input	Detector 259 Alarm	Detector 259 Trouble	Not Used	
60	Input	Detector 260 Alarm	Detector 260 Trouble	Not Used	
61	Input	Detector 261 Alarm	Detector 261 Trouble	Not Used	
62	Input	Detector 262 Alarm	Detector 262 Trouble	Not Used	
63	Input	Detector 263 Alarm	Detector 263 Trouble	Not Used	
64	Input	Detector 264 Alarm	Detector 264 Trouble	Not Used	

Table A-8 ACS Annunciator Selection Group 7

ACS Annunciator Selection Group 8

ACS Point Number	Point Type	Red LED Indicates	Yellow LED Indicates	Switch Function	Comments
1	Input	Detector 165 Alarm	Detector 165 Trouble	Not Used	
2	Input	Detector 166 Alarm	Detector 166 Trouble	Not Used	
3	Input	Detector 167 Alarm	Detector 167 Trouble	Not Used	
4	Input	Detector 168 Alarm	Detector 168 Trouble	Not Used	
5	Input	Detector 169 Alarm	Detector 169 Trouble	Not Used	
6	Input	Detector 170 Alarm	Detector 170 Trouble	Not Used	
7	Input	Detector 171 Alarm	Detector 171 Trouble	Not Used	
8	Input	Detector 172 Alarm	Detector 172 Trouble	Not Used	
9	Input	Detector 173 Alarm	Detector 173 Trouble	Not Used	
10	Input	Detector 174 Alarm	Detector 174 Trouble	Not Used	
11	Input	Detector 175 Alarm	Detector 175 Trouble	Not Used	
12	Input	Detector 176 Alarm	Detector 176 Trouble	Not Used	
13	Input	Detector 177 Alarm	Detector 177 Trouble	Not Used	
14	Input	Detector 178 Alarm	Detector 178 Trouble	Not Used	
15	Input	Detector 179 Alarm	Detector 179 Trouble	Not Used	
16	Input	Detector 180 Alarm	Detector 180 Trouble	Not Used	
17	Input	Detector 181 Alarm	Detector 181 Trouble	Not Used	
18	Input	Detector 182 Alarm	Detector 182 Trouble	Not Used	
19	Input	Detector 183 Alarm	Detector 183 Trouble	Not Used	
20	Input	Detector 184 Alarm	Detector 184 Trouble	Not Used	
21	Input	Detector 185 Alarm	Detector 185 Trouble	Not Used	
22	Input	Detector 186 Alarm	Detector 186 Trouble	Not Used	
23	Input	Detector 187 Alarm	Detector 187 Trouble	Not Used	
24	Input	Detector 188 Alarm	Detector 188 Trouble	Not Used	
25	Input	Detector 189 Alarm	Detector 189 Trouble	Not Used	
26	Input	Detector 190 Alarm	Detector 190 Trouble	Not Used	
27	Input	Detector 191 Alarm	Detector 191 Trouble	Not Used	
28	Input	Detector 192 Alarm	Detector 192 Trouble	Not Used	
29	Input	Detector 193 Alarm	Detector 193 Trouble	Not Used	
30	Input	Detector 194 Alarm	Detector 194 Trouble	Not Used	
31	Input	Detector 195 Alarm	Detector 195 Trouble	Not Used	
32	Input	Detector 196 Alarm	Detector 196 Trouble	Not Used	
33	Input	Detector 265 Alarm	Detector 265 Trouble	Not Used	
34	Input	Detector 266 Alarm	Detector 266 Trouble	Not Used	
35	Input	Detector 267 Alarm	Detector 267 Trouble	Not Used	
36	Input	Detector 268 Alarm	Detector 268 Trouble	Not Used	
37	Input	Detector 269 Alarm	Detector 269 Trouble	Not Used	
38	Input	Detector 270 Alarm	Detector 270 Trouble	Not Used	
39	Input	Detector 271 Alarm	Detector 271 Trouble	Not Used	
40	Input	Detector 272 Alarm	Detector 272 Trouble	Not Used	
41	Input	Detector 273 Alarm	Detector 273 Trouble	Not Used	
42	Input	Detector 274 Alarm	Detector 274 Trouble	Not Used	
43	Input	Detector 275 Alarm	Detector 275 Trouble	Not Used	
44	Input	Detector 276 Alarm	Detector 276 Trouble	Not Used	
45	Input	Detector 277 Alarm	Detector 277 Trouble	Not Used	
46	Input	Detector 278 Alarm	Detector 278 Trouble	Not Used	
47	Input	Detector 279 Alarm	Detector 279 Trouble	Not Used	
48	Input	Detector 280 Alarm	Detector 280 Trouble	Not Used	
49	Input	Detector 281 Alarm	Detector 281 Trouble	Not Used	
50	Input	Detector 282 Alarm	Detector 282 Trouble	Not Used	
51	Input	Detector 283 Alarm	Detector 283 Trouble	Not Used	
52	Input	Detector 284 Alarm	Detector 284 Trouble	Not Used	
53	Input	Detector 285 Alarm	Detector 285 Trouble	Not Used	
54	Input	Detector 286 Alarm	Detector 286 Trouble	Not Used	
55	Input	Detector 187 Alarm	Detector 287 Trouble	Not Used	
56	Input	Detector 288 Alarm	Detector 288 Trouble	Not Used	
57	Input	Detector 289 Alarm	Detector 289 Trouble	Not Used	
58	Input	Detector 290 Alarm	Detector 290 Trouble	Not Used	
59	Input	Detector 291 Alarm	Detector 291 Trouble	Not Used	
60	Input	Detector 292 Alarm	Detector 292 Trouble	Not Used	
61	Input	Detector 293 Alarm	Detector 293 Trouble	Not Used	
62	Input	Detector 294 Alarm	Detector 294 Trouble	Not Used	
63	Input	Detector 295 Alarm	Detector 295 Trouble	Not Used	
64	Input	Detector 296 Alarm	Detector 296 Trouble	Not Used	

Table A-9 ACS Annunciator Selection Group 8

ACS Annunciator Selection Group 9

ACS Point Number	Point Type	Red LED Indicates	Yellow LED Indicates	Switch Function	Comments
1	Output	Module P1.1 Active	Module P1.1 Trouble	Controls Module P1.1	
2	Output	Module P1.2 Active	Module P1.2 Trouble	Controls Module P1.2	
3	Output	Module P1.3 Active	Module P1.3 Trouble	Controls Module P1.3	
4	Output	Module P1.4 Active	Module P1.4 Trouble	Controls Module P1.4	
5	Output	Module P1.5 Active	Module P1.5 Trouble	Controls Module P1.5	
6	Output	Module P1.6 Active	Module P1.6 Trouble	Controls Module P1.6	
7	Output	Module P1.7 Active	Module P1.7 Trouble	Controls Module P1.7	
8	Output	Module P1.8 Active	Module P1.8 Trouble	Controls Module P1.8	
9	Output	Module P2.1 Active	Module P2.1 Trouble	Controls Module P2.1	
10	Output	Module P2.2 Active	Module P2.2 Trouble	Controls Module P2.2	
11	Output	Module P2.3 Active	Module P2.3 Trouble	Controls Module P2.3	
12	Output	Module P2.4 Active	Module P2.4 Trouble	Controls Module P2.4	
13	Output	Module P2.5 Active	Module P2.5 Trouble	Controls Module P2.5	
14	Output	Module P2.6 Active	Module P2.6 Trouble	Controls Module P2.6	
15	Output	Module P2.7 Active	Module P2.7 Trouble	Controls Module P2.7	
16	Output	Module P2.8 Active	Module P2.8 Trouble	Controls Module P2.8	
17	Output	Module P3.1 Active	Module P3.1 Trouble	Controls Module P3.1	
18	Output	Module P3.2 Active	Module P3.2 Trouble	Controls Module P3.2	
19	Output	Module P3.3 Active	Module P3.3 Trouble	Controls Module P3.3	
20	Output	Module P3.4 Active	Module P3.4 Trouble	Controls Module P3.4	
21	Output	Module P3.5 Active	Module P3.5 Trouble	Controls Module P3.5	
22	Output	Module P3.6 Active	Module P3.6 Trouble	Controls Module P3.6	
23	Output	Module P3.7 Active	Module P3.7 Trouble	Controls Module P3.7	
24	Output	Module P3.8 Active	Module P3.8 Trouble	Controls Module P3.8	
25	Output	Module P4.1 Active	Module P4.1 Trouble	Controls Module P4.1	
26	Output	Module P4.2 Active	Module P4.2 Trouble	Controls Module P4.2	
27	Output	Module P4.3 Active	Module P4.3 Trouble	Controls Module P4.3	
28	Output	Module P4.4 Active	Module P4.4 Trouble	Controls Module P4.4	
29	Output	Module P4.5 Active	Module P4.5 Trouble	Controls Module P4.5	
30	Output	Module P4.6 Active	Module P4.6 Trouble	Controls Module P4.6	
31	Output	Module P4.7 Active	Module P4.7 Trouble	Controls Module P4.7	
32	Output	Module P4.8 Active	Module P4.8 Trouble	Controls Module P4.8	
33	Output	Module P5.1 Active	Module P5.1 Trouble	Controls Module P5.1	
34	Output	Module P5.2 Active	Module P5.2 Trouble	Controls Module P5.2	
35	Output	Module P5.3 Active	Module P5.3 Trouble	Controls Module P5.3	
36	Output	Module P5.4 Active	Module P5.4 Trouble	Controls Module P5.4	
37	Output	Module P5.5 Active	Module P5.5 Trouble	Controls Module P5.5	
38	Output	Module P5.6 Active	Module P5.6 Trouble	Controls Module P5.6	
39	Output	Module P5.7 Active	Module P5.7 Trouble	Controls Module P5.7	
40	Output	Module P5.8 Active	Module P5.8 Trouble	Controls Module P5.8	
41	Output	Module P6.1 Active	Module P6.1 Trouble	Controls Module P6.1	
42	Output	Module P6.2 Active	Module P6.2 Trouble	Controls Module P6.2	
43	Output	Module P6.3 Active	Module P6.3 Trouble	Controls Module P6.3	
44	Output	Module P6.4 Active	Module P6.4 Trouble	Controls Module P6.4	
45	Output	Module P6.5 Active	Module P6.5 Trouble	Controls Module P6.5	
46	Output	Module P6.6 Active	Module P6.6 Trouble	Controls Module P6.6	
47	Output	Module P6.7 Active	Module P6.7 Trouble	Controls Module P6.7	
48	Output	Module P6.8 Active	Module P6.8 Trouble	Controls Module P6.8	
49	Output	Module P7.1 Active	Module P7.1 Trouble	Controls Module P7.1	
50	Output	Module P7.2 Active	Module P7.2 Trouble	Controls Module P7.2	
51	Output	Module P7.3 Active	Module P7.3 Trouble	Controls Module P7.3	
52	Output	Module P7.4 Active	Module P7.4 Trouble	Controls Module P7.4	
53	Output	Module P7.5 Active	Module P7.5 Trouble	Controls Module P7.5	
54	Output	Module P7.6 Active	Module P7.6 Trouble	Controls Module P7.6	
55	Output	Module P7.7 Active	Module P7.7 Trouble	Controls Module P7.7	
56	Output	Module P7.8 Active	Module P7.8 Trouble	Controls Module P7.8	
57	Output	Module P8.1 Active	Module P8.1 Trouble	Controls Module P8.1	
58	Output	Module P8.2 Active	Module P8.2 Trouble	Controls Module P8.2	
59	Output	Module P8.3 Active	Module P8.3 Trouble	Controls Module P8.3	
60	Output	Module P8.4 Active	Module P8.4 Trouble	Controls Module P8.4	
61	Output	Module P8.5 Active	Module P8.5 Trouble	Controls Module P8.5	
62	Output	Module P8.6 Active	Module P8.6 Trouble	Controls Module P8.6	
63	Output	Module P8.7 Active	Module P8.7 Trouble	Controls Module P8.7	
64	Output	Module P8.8 Active	Module P8.8 Trouble	Controls Module P8.8	

Table A-10 ACS Annunciator Selection Group 9

Connecting Annunciators

Overview

This section contains guidelines, installation instructions, and wiring diagrams for connecting annunciator devices to the control panel. Table A-11 lists each device covered in this section:

Topic	Covers	Refer to page...
ADT-LCD-80 Terminal Mode EIA-485 connections	Connecting an ADT-LCD-80 in terminal mode to the CPU.	A-13
ADT-LCD-80 ACS Mode EIA-485 Connection (CPU, TB4)	Connecting an ADT-LCD-80 in Terminal Mode, the ADT-LCD-80 connects to TB4 on the CPU using a looped EIA-485 circuit.	A-14
Powering ADT-ACS-, ADT-ACM-, and ADT-LDM-type Annunciators	Connecting an ADT-LCD-80 operated in ACS mode to TB3 on the CPU.	A-15
ADT-ACS and ADT-LDM Series EIA-485 Connection	Connecting an ACS series annunciator, (including the ADT-LDM-80), to TB4 on the CPU using an EIA-485 circuit.	A-16

Table A-11 Annunciator Topics

ADT-LCD-80 Terminal Mode EIA-485 Connection (CPU, TB3)

Connection Guidelines

An ADT-LCD-80 operating in Terminal mode connects to TB3 on the CPU using a looped power-limited and supervised EIA-485 circuit as shown in Figure A-1.

Note: Refer to the ADT-LCD-80 Manual for additional information.

- Maximum distance between the control panel and the first or last ADT-LCD-80 and between each ADT-LCD-80: 6,000 feet (using 16 AWG wire).
- Use overall foil/braided-shield twisted-pair cable suitable for EIA-485 applications.
- An EIA-485 circuit is rated at 5.5 VDC max., 60 mA max.
- For non-English language systems, ADT-LCD-80 standby current equals the alarm current (100 mA).
- Each ADT-LCD-80 must connect to regulated 24 VDC power. Power an ADT-LCD-80 from the MPS-400 power supply or a separate UL-listed power supply (For power connections, see Figure A-3 on page A-15.)

Connecting ADT-LCD-80s in Terminal Mode

Set ADT-LCD-80 DIP switches as follows:

1. Install R-120 resistors across the IN and OUT terminals of each ADT-LCD-80.
2. Set SW4 and SW5 on the ADT-LCD-80 to the TERM position (SW1-7 ON).
3. Set DIP Switch SW3-1 and SW3-2 to OFF on all ADT-LCD-80s except the last ADT-LCD-80.
4. Set SW3-1 and SW3-2 to ON on the last ADT-LCD-80.

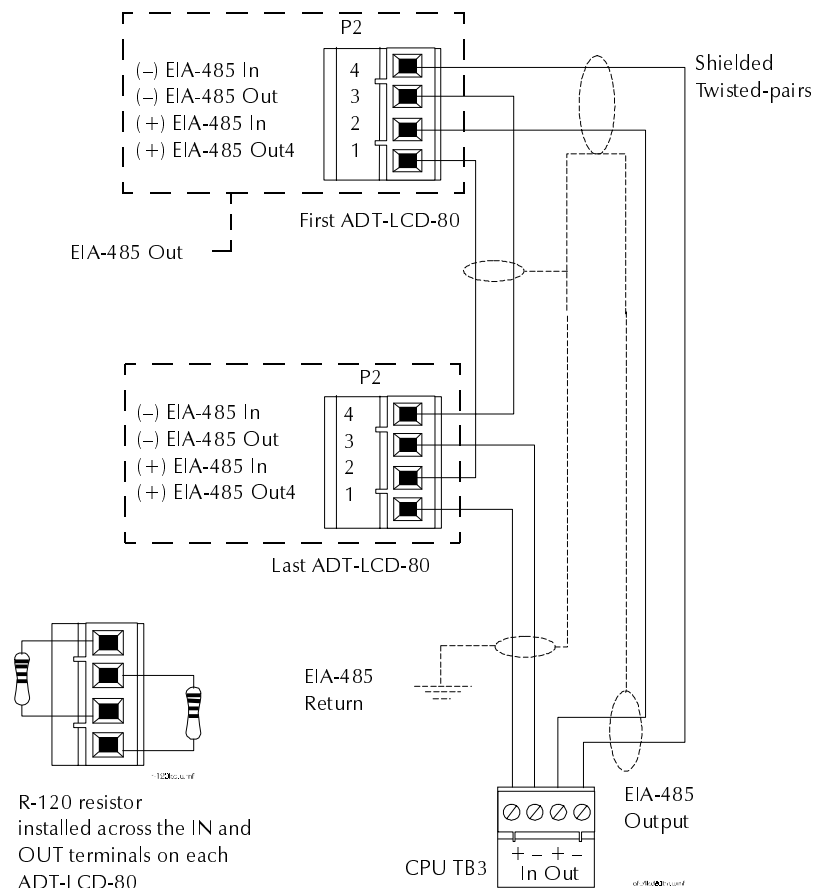

Figure A-1 Terminal Mode EIA-485 Connection

ADT-LCD-80 ACS Mode EIA-485 Connection (CPU, TB4)

Connection Guidelines

When operating an ADT-LCD-80 in ACS Mode, the ADT-LCD-80 connects to TB4 on the CPU using a looped EIA-485 circuit as shown in Figure A-2.

- EIA-485 circuits are power-limited and supervised.
- ADT-LCD-80s require connection of operating power.
- Maximum distance between the control panel and the first or last ADT-LCD-80 and between each ADT-LCD-80: 6,000 feet (using 16 AWG wire).
- If powering ADT-LCD-80s by a separate, UL-listed power supply, you can connect up to 32 devices.
- Use twisted-pair cable with a characteristic impedance of approximately 120 ohms.
- The EIA-485 circuit is rated 5.5 VDC max., 60 mA max.
- Refer to the ADT-LCD-80 Manual for additional information.

Connecting ADT-LCD-80s in ACS Mode

1. Connect EIA-485 power to CPU terminals TB4-1 (+) and TB4-2 (-).
2. Set the ADT-LCD-80 start address to address 01.
3. Set SW2 to 1; set SW3-1 and SW3-2 to OFF.
4. Set the ADT-LCD-80 to a size of 128 points.
5. Set the character display: To use a 40-character display, set SW5 OFF and SW6 ON; to use a 20-character display, set SW5 ON and SW6 OFF.
6. Install a 120 ohm terminating resistor on the last ADT-LCD-80.

Note: Power connections are supervised and power-limited.

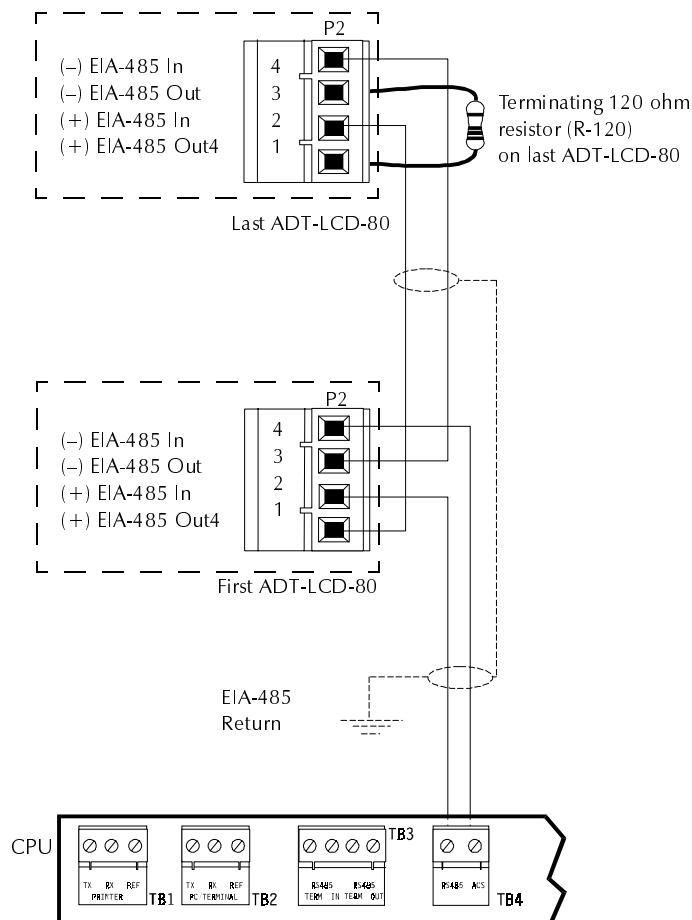

Figure A-2 ADT-LCD-80 ACS Mode EIA-485 Connection

Powering ADT ACS-, LDM-, ACM-, and LCD-type Annunciators

Overview

An ADT-LCD-80 operated in ACS mode connects to TB4 on the CPU using a power-limited EIA-485 circuit. Figure A-3 shows power connections for ADT-LCD-, ADT-ACM-, and ADT-ACS- type annunciators; and Figure A-4 shows power connections for ADT-LCD-80s. The following guidelines apply to Figure A-3 and Figure A-4:

- The power run to the ADT-LCD-80 or ACS Annunciator does not require a Power Supervision Relay. Loss of power is inherently supervised through a Communication Loss.
- The maximum ADT-LCD-80 current draw from the power supply is 500 mA.
- Power must be supplied from a regulated 24 VDC power supply.

Power Connections

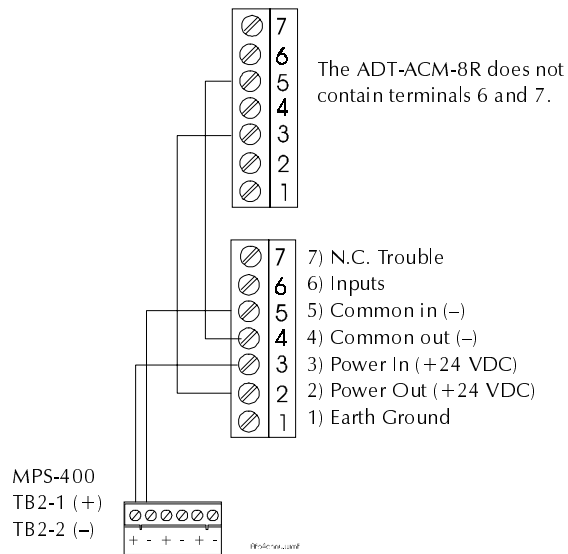

Figure A-3 Power Connections for ADT-LCD, ACS Type Annunciators

Power Connections for ADT-LCD-80 Annunciators

Figure A-4 shows typical power connections for ADT-LCD-80 annunciators:

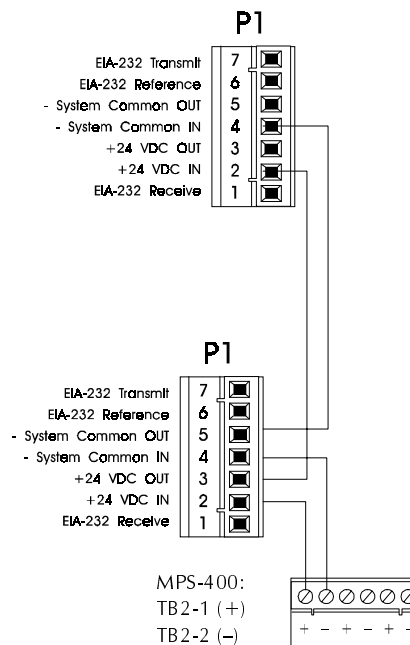

Figure A-4 Power Connections for ADT-LCD-80s

ADT-ACS and ADT-LDM Series EIA-485 Connection

Connection Guidelines

When operating an ADT-ACS series annunciator, including the ADT-LDM-32, connect the annunciator to TB4 on the CPU using an EIA-485 circuit as shown in Figure A-5.

- The circuit is power-limited and supervised.
- You can connect up to 32 devices (such as ADT-ACMs, ADT-LDMs, and ADT-AFMs) to the control panel using ten unique addresses. Only one device per address can answer back.
- Maximum distance between the control panel and the furthest annunciator: 6,000 feet (@16 AWG).
- Use twisted-pair cable with a characteristic impedance of approximately 120 ohms.
- An EIA-485 circuit is rated 5.5 VDC max., 60 mA max.
- Refer to the ADT-ACS Manual and the ADT-LDM Manual for additional information.

EIA-485 Connections

Connect ADT-ACS- and ADT-LDM- series devices to the CPU as shown in Figure A-5, making sure to install a 120 ohm terminating resistor on the last annunciator in the series.

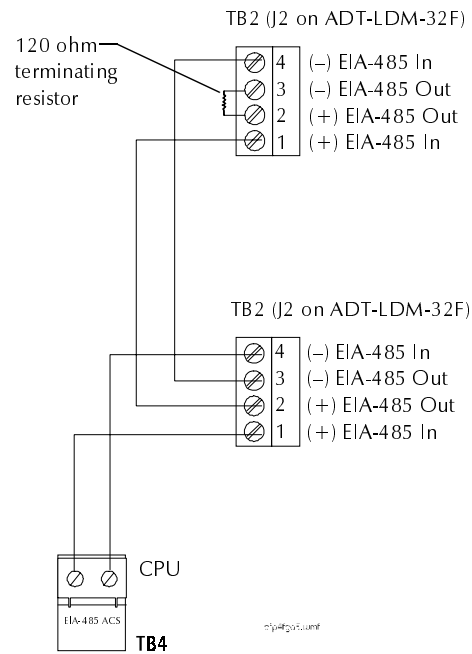

Figure A-5 ACS and ADT-LDM Series EIA-485 Connection

Notes

Appendix B: Wire Requirements

Note: If running an SLC in conduit with Notification Appliance Circuits, you can reduce problems by exclusively using electronic sounders (such as the MA/SS-24 Series) instead of more electronically noisy notification appliances (such as electromechanical bells or horns).

Each type of circuit within the Fire Alarm Control System requires use of a specific wire type to ensure proper circuit operation. The wire gauge of a particular circuit depends on the length of that circuit. Use Table B-1 to determine the specific wiring requirements for each circuit.

Compliance with the Federal Communications Commission (FCC) and Canadian Department of Communication regulations on electrical energy radiation requires the following: Use twisted-pair shielded wire for any wiring entering or exiting the Unimode 400 cabinet that is not enclosed in conduit.

Circuit Type	Circuit Function	Wire Requirements	Distance (feet)	Typical Wire Type
SLC Loop (power-limited)	Connects to intelligent and addressable modules.	Twisted-shielded pair, 12 to 18 AWG. 40 ohms, maximum per length of Style 6 and 7 loops. 40 ohms per branch maximum for Style 4 loops. Untwisted, unshielded wire, in conduit or outside of conduit.	10,000 8,000 4,875 3,225 1,000	12 AWG Belden 9583 WPW 999 Genesis 4410 14 AWG Belden 9581 WPW 995 Genesis 4408 16 AWG Belden 9575 WPW 991 Genesis 4406 18 AWG Belden 9574 WPW 975 Genesis 4402 18-12 AWG
EIA-485 (power-limited)	Connects to ADT-LCD-80 or to Annunciator Control System (ACS) modules	Twisted-shielded pair with a characteristic impedance of 120 ohms. 18 AWG minimum.	6,000 (max)	Belden 9860 (16 AWG)
EIA-232 (power-limited)	Connects to PRN, P40 Remote Printers, CRT, or PC.	Twisted-shielded pair. 18 AWG minimum.	50 (without modem)	Belden 9860 (16 AWG)
M500M, M501M (power-limited)	Initiating Device Circuit (IDC)	12-18 AWG. Maximum circuit resistance is 20 ohms.	To meet 20 ohms	12-18 AWG
M500CH (power-limited)	Notification Appliance Circuit (NAC)	12-18 AWG. MPS-24A: At alarm current level, no more than a 1.2 V drop at the end of the circuit, or sized to provide the minimum rated operating voltage of the appliances used.	To meet 1.2 V drop, or sized to provide the minimum rated operating voltage of the appliances used.	12-18 AWG
24 VDC Power Runs (power-limited)	To annunciators and M500CH	12-18 AWG. Size wire so that no more than 1.2 V drop across wire run from supply source to end of any branch.	To meet 1.2 volt drop	12-18 AWG
NR45-24	Remote Secondary Power Source	12 AWG in conduit.	20 (max)	12 AWG

Table B-1 Unimode 400 Wiring Requirements

Notes

Appendix C: Compatible Equipment

This document lists ADT, Notifier, and System Sensor equipment that is compatible with the control panel. Also, refer to the Device Compatibility Document for compatible equipment.

ADT Compatible Equipment

Table C-1 contains a list of ADT equipment that is compatible with the control panel:

ADT-ABF-1 Annunciator Flush Box ADT-ABF-1D Annunciator Flush Box with Door ADT-ABF-2 Annunciator Flush Box ADT-ABF-2D Annunciator Flush Box with Door ADT-ABF-4 Annunciator Flush Box ADT-ABF-4D Annunciator Flush Box with Door ABM-16AT Annunciator Blank Module ABM-32A Annunciator Module Blank ADT-ABS-1T Annunciator Surface Box ADT-ABS-2 Annunciator Surface Box ADT-ABS-8R Annunciator Backbox for ACM-8R ADT-ACM-16AT Annunciator Control Module ADT-ACM-32A Annunciator Control Module ADT-ACM-8R Annunciator Control Module ADP-4 Annunciator Dress Panel AEM-16AT Annunciator Expander Module AEM-32A Annunciator Expander Module ADT-AFM-16A Annunciator Fixed Module ADT-AFM-16AT Annunciator Fixed Module ADT-AFM-32A Annunciator Fixed Module ADT-AKS-1 Annunciator Key Switch ARM-4 Auxiliary Relay Module ADT-BGX-101L Addressable manual pull station ADT-CAB-A3 A-size cabinet ADT-CAB-B3 B-size cabinet ADT-CAB-C3 C-size cabinet ADT-CAB-D3 D-size cabinet	ADT-CAB-400AA AA-size cabinet ADT-DR-AA/DR-400AA AA-size Door ADT-DR-A3 A-size Door ADT-DR-B3 B-size Door ADT-DR-C3 C-size Door ADT-DR-D3 D-size Door BM-1 Blank Module BP-3 Battery Dress Panel CHS-4L Chassis CHS-4M Chassis ADT-CPU-400 CPU for Unimode 400 CRE-4 Control Relay Expander CRM-4 Control Relay Module DCM-4 Dual Channel Module ADT-DP-400AA Dress Panel for ADT-CAB-AA DP-1 Dress Panel DPDW-1 Double Well Dress Panel DPSW-1 Single Well Dress Panel FPJ Fireman's Phone Jack ICE-4 Indicating Control Expander ICM-4 Indicating Control Module ADT-LCD-80 Liquid Crystal Display Module LCD-80TM Terminal Mode LCD Annunciator ADT-LDM-32 Lamp Driver Module LDM-E32 Lamp Driver Module LDM-R32 Lamp Driver Module ADT-NIB-96 Network Interface Board V54095 Keltron Printer RPJ-1 Fireman's Phone Jack ADT-UZC-256 Universal Zone Coder UNI•TILITY Off-line Programming Kit VCE-4 Voice Control Expander VCM-4 Voice Control Module
--	---

Table C-1 ADT Compatible Equipment

Notifier Compatible Equipment

Table C-2 contains a list of Notifier equipment that is compatible with the control panel:

4XTM Transmitter Module AA-30 30-Watt Audio Amplifier AA-100 100-Watt Audio Amplifier AA-120 120-Watt Audio Amplifier ACT-1 Audio Coupling Transformer AMG-1 Audio Message Generator AMG-E Audio Message Generator ATG-2 Audio Tone Generator AVPS-24 Audio/Visual Power Supply BB-17 Battery Box BB-55 Battery Box CHG-120 Battery Charger CRT-2 Video Display Monitor with Keyboard FCPS-24 Field Charger Power Supply FFT-7 Fire Fighters Telephone FFT-7S Fire Fighters Telephone FHS Fireman's Handset L20-300-BX Enclosure; recessed mount L20-310-BX Enclosure; surface mount N-ARA-10 Agent Release Pull Station N-ELR Assortment ELR Pack with Mounting Plate PRN-4 80-Column Printer PS-12120 Battery 12-volt, 12 amp-hour	PS-12170 Battery 12-volt, 17 amp-hour PS-12250 Battery 12-volt, 25 amp-hour PS-12550 Battery 12-volt, 55 amp-hour SBB-A3 A-size Backbox SBB-B3 B-size Backbox SBB-C3 C-size Backbox SBB-D3 D-size Backbox STS-200 Security Tamper Switch for ADT-CAB-400AA R-120 120 Ohm End-of-Line Resistor R-2.2K 2.2K End-of-Line Resistor R-27K 27K End-of-Line Resistor R-470 470 End-of-Line Resistor R-47K 47K End-of-Line Resistor RPT-485F EIA-485 Repeater (Fiber) RPT-485W EIA-485 Repeater (Wire) RPT-485WF EIA-485 Repeater (Wire/Fiber) TR-500 Trim Ring for ADT-CAB-400AA UDACT Universal Digital Alarm Communicator Transmitter XPC-8 Transponder Control Module XPDP Transponder Dress Panel XPM-8 Transponder Monitor Module XPM-8L Transponder Monitor Module XPP-1 Transponder Processor XPR-8 Transponder Relay Module
---	---

Table C-2 Notifier Compatible Equipment

System Sensor Compatible Equipment

Table C-3 contains a list of System Sensor equipment that is compatible with the control panel:

1251 Intelligent Ionization Smoke Detector 1551 Intelligent Ionization Smoke Detector 2551 Intelligent Photoelectric Detector 2551TH Intelligent Photoelectric Detector 2251 Intelligent Photoelectric Detector 3251 Advanced Multi-Sensor Intelligent Detector A2143-00 End of Line Resistor Assembly B501B detector base B501BH sounder detector base	B524BI isolator detector base B524RB relay detector base DH500/DH502 Duct detector M500X Loop Fault Isolator Module M500CH Addressable Control Module M500M Addressable Monitor Module M501M Addressable Mini Monitor Module M502M Addressable Monitor Module RA400 Remote Annunciator RA400Z Remote Annunciator with diode
--	--

Table C-3 System Sensor Compatible Equipment

Appendix D: CRT-2 Configuration

Overview

The CRT-2 communicates with the control panel through a protocol defined by thirteen groups of parameters. To access a parameter group, press the corresponding function key (F1-F13) as shown in Table D-1. You can then program parameters in each group.

Setting CRT-2 Parameters

Enter the CRT-2 setup menu by pressing and holding the <Ctrl> key while pressing the <Scroll Lock> key. Use arrow keys to move through the selections in each setup group; press the space bar to view the options for each parameter. When finished programming all setup groups, press the <Pause> key. To save all changes, press <Y>.

Function Key	CRT-2 Parameters		
F1: Quick	Emulation=CRT-2 Comm Mode=Full Duplex Enhanced=On	EIA Baud Rate=2400 Aux Baud Rate=2400 Language=U.S.	EIA Data Format=8/1/N Aux Data Format=7/1/E Host/Printer=EIA/Aux
F2: Genrl	Emulation=CRT-2 Auto Font Load=On Monitor Mode=Off Host/Printer=EIA/Aux	Enhanced=On Auto Page=Off Bell Volume=09	Auto Wrap=Off Auto Scroll=On Warning Bell=On
F3: Displ	Page Length=24 Display Cursor=On Columns=80 Scroll=Jump	Screen Length=26 Lines Cursor=Blink Line Width Change Clear=Off Refresh Rate=60 Hz	Screen Video=Normal Auto Adjust Cursor=On Speed=Normal Overscan Borders=Off
F4: Kybd	Language=U.S. Keyclick=Off Key Lock=Caps	Char Set Mode=ASCII Key Repeat=Off Keyboard Present=Yes	Key Mode=ASCII Margin Bell=Off
F5: Keys	Enter Key=<CR> Alt Key=Meta Pound Key=U.S.	Return Key=<CR> Disconnect=Pause	Backspace=<BS>/ Desk Acc=Disabled
F6: Ports	EIA Baud Rate=2400 Aux Baud Rate=2400 EIA Xmt=Xon-Xoff Aux Xmt=Xon-Xoff EIA Break=Off Aux Break=Off	EIA Data Format=8/1/N Aux Data Format=7/1/E EIA Recv=Xon-Xoff(XPC) Aux Recv=Xon-Xoff(XPC) EIA Modem Control=Off Aux Modem Control=Off	EIA Parity Check=On Aux Parity Check=On EIA Xmt Pace=Baud Aux Xmt Pace=Baud EIA Disconnect=2 sec Aux Disconnect=2 sec
F7: Host	Comm Mode=Full Duplex Recv =Ignore Send Block Term=<CR>	Local=Off Send ACK=On Null Suppress=On	Recv <CR>=<CR> Send Line Term=<CR><LF>
F8: Print	Prnt Line Term=<CR><LF>	Prnt Block Term=<CR>	Secondary Recv=Off
F9: Emul	Attribute=Page WPRT Intensity=Dim WPRT Blink=Off Status Line=Off	Bright Video=Off WPRT Reverse=Off Display NV Labels=Off Fkey Speed=Normal	Page Edit=Off WPRT Underline=Off Save Labels=On
F10	Setup Group F10 does not affect communications with the control panel.		
F11	Setup Group F11 does not affect communications with the control panel.		
F12: Prog	Program the function keys as follows: F1 ~A F2 ~B F3 ~C F4 ~D F5 ~E F6 ~F F7 ~G F8 ~H F9 ~I F10 ~J F11 ~K F12 ~L F13 ~M F14 ~N F15 ~O F16 ~P Shift F13 ~Q		

Table D-1 CRT-2 Function Keys and Parameters

Uploading or Downloading the Operating Program

Note: For instructions on using Uni•Tility Upload/Download software, refer to the Uni•Tility on-line help files.

You can also use the CPU EIA-232 port to upload and download the control panel operating program, using Uni•Tility Upload/Download software. Download operations that change the basic program of the control panel must be performed by responsible service personnel in attendance at the control panel. After downloading a program, test the control panel in accordance with NFPA 72-1993.

Appendix E: Terminal Interface Protocol

General Description

The control panel can communicate with a remote terminal or computer connected to the CPU EIA-232 port. (Refer to Section 2, *Installation*, for installation information.) Set up the EIA-232 port for interactive operation or for monitoring only. Interactive operation requires that all equipment be UL-listed under UL Standard for Safety UL864 and be installed and set up as directed under Local Terminal Mode (LocT) or Local Monitor Mode (LocM). EDP listed equipment is allowed for ancillary system monitoring when the system is installed and set up as directed under Remote Monitor Mode (RemT). You can also use EDP-listed equipment for system servicing or programming.

The EIA-232 ports on some terminals/computers, including the CRT-2, are not isolated from earth ground. These devices should be connected to the control panel through isolation modems, because direct connection can cause a ground fault.

Operating Modes

The control panel provides three operating modes for the EIA-232 port, Local Terminal, Local Monitor, and Remote Monitor. You select the operating mode during control panel programming (system parameters). For more information, refer to the Unimode 400 Programming Manual.

The following subsections outline the functions, password requirements, and additional information for each operating mode.

Local Terminal Mode (LocT)

Functions, passwords, and special requirements of Local Terminal Mode (LocT) are:

- Functions:** Read Status, Alter Status, and Control Functions (Table E-1).
- Passwords:** User-defined password for Alter Status functions.
- Requirements:** The terminal must be mounted in a UL-864 listed enclosure, a Rack-51, Rack-67, or positioned to provide equivalent protection against unauthorized use.

Table E-1 summarizes the functions available with the Local Terminal mode:

Function	Lets you...
Read Status	<ul style="list-style-type: none"> • Display the status of an individual point (Detector, Module, Panel Circuit, or Zone). • Display a list of all the points in Alarm or trouble. • Display a list of all programmed points in the system. • Step through the history buffer event by event. • Display the entire history buffer.
Alter Status	<ul style="list-style-type: none"> • Disable/Enable an individual point. • Change the sensitivity of a detector. • Clear the verification counter of all detectors. • Clear the entire history buffer. • Set the AWACS alert and action levels.
Control Functions	<ul style="list-style-type: none"> • Acknowledge. • Alarm Silence. • System Reset. • Alarm Activate.

Table E-1 LocT Functions

Local Monitor Mode (LocM)

Functions, passwords, and special requirements of Local Monitor Mode (LocM) are:

- Functions:** Read Status, Alter Status, and Control Functions (Table E-2).
- Passwords:** User-defined password for Alter Status and Control functions.
- Requirements:** Password security feature for Control Functions eliminates the need for mounting the CRT-2 in an enclosure.

Table E-3 summarizes the functions available with the Local Monitor mode:

Function	Lets you...
Read Status	<ul style="list-style-type: none"> • Display the status of an individual point (Detector, Module, Panel Circuit, or Zone). • Display a list of all the points in Alarm or trouble. • Display a list of all programmed points in the system. • Step through the history buffer event by event. • Display the entire history buffer.
Alter Status	<ul style="list-style-type: none"> • Disable/Enable an individual point. • Change the sensitivity of a detector. • Clear the verification counter of all detectors. • Clear the entire history buffer. • Set the AWACS alert and action levels.
Control Functions	<ul style="list-style-type: none"> • Acknowledge • Alarm Silence • System Reset • Alarm Activate

Table E-2 LocM Functions

Remote Terminal Mode (RemT) Functions, passwords, and special requirements of Remote Terminal Mode (RemT) are:

- Functions:** Read Status only. See Table E-3.
- Passwords:** None
- Requirements:** Use with UL EDP-listed terminals, including personal computers with UNI•TILITY Upload/Download software or terminal emulation software. Intended for terminals connected through modems, including modems connected through a public switched telephone network.

Table E-3 summarizes the functions available with the RemT mode:

Functions	Lets you...
Read Status	<ul style="list-style-type: none"> • Display the status of an individual point (Detector, Module, Panel Circuit, or Zone). • Display a list of all the points in Alarm or trouble. • Display a list of all programmed points in the system. • Step through the history buffer event by event. • Display the entire history buffer.
Alter Status	N/A
Control Functions	N/A

Table E-3 RemT Functions

Using the CRT-2 for Read Status

Overview

This section shows how to do Read Status functions from a CRT-2.

Function	Lets you...
Read Point	Read the status of any point in the system (detectors, modules, panel circuits, software zones, and system parameters).
Alm/Tbl Status	Display a list of all devices in the system that are in Alarm or trouble.
Read All Points	Display a list of all points programmed in the system. This list will display the status of all addressable detectors, modules, panel circuits, system parameters and software zones.
History Step	Step through the history buffer one event at a time.
History-All	Send the entire history buffer to the CRT, from the most recent event to the oldest event.

Table E-4 Read Status Functions

Accessing Read Status Options

Access the Read Status function from the CRT-2 by following these steps.

1. Turn on the CRT-2, which is connected to the control panel.
2. Press the Read Status function key – F1. The control panel displays the Read Status menu options:

Press



```
Rd Point=1, Rd Alm/Tbl=2, All Points=3, Hist:Step=4/Al1=5, Al1-Hist:Step=6/Al=7
```

From the Read Status menu, you can select options 1-5.

Read Point

From the Read Status menu, select option 1. The CRT-2 displays the following:

Press

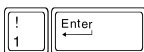

Address (01-99)

SLC number

Number

Type D(nnn), M(nnn), P(nn), Z(nn), f(nn),, R(n) or S(n) then hit Enter

Enter the following:

Note:

Press  to scroll forward through a list of devices.

Press  to scroll back through a list of devices.

1. Enter the first letter of the device.
2.
 - Detector
 - Module
 - Panel circuit
 - Zone
 - Special Function
 - Releasing Zone; or
 - System Parameter.
3. Enter the address or number of the device.
4. Press <Enter>.

Example Read the point for detector 101:

Press



```
NORMAL SMOKE (PHOTO) DETECTOR ADDR 101 Z03 Z Z Z Z 000%A5 PA:3 ** D101
```

```
NORMAL SMOKE (ION) DETECTOR ADDR 102 Z02 Z Z Z Z 000%A5 PA:0 ** D102
```

Display Devices in Alarm or Trouble

From the Read Status menu, select Rd Alm/Tbl, option 2:

Press



```
TROUBL SMOKE (PHOTO) DETECTOR ADDR 101 Z03 INVALID REPLY 01;09P 01/013/97 D101
TROUBL SMOKE (ION) DETECTOR ADDR 102 Z02 INVALID REPLY 01;09P 01/013/97 D102
TROUBL SMOKE MONITOR MODULE ADDR 101 Z04 INVALID REPLY 01;09P 01/013/97 M101
```

Display the Status of all Programmed Points

From the Read Status menu, select All Points, option 3. The CRT-2 displays a list of the status of all addressable detectors, modules, panel circuits, system parameters and software zones:

Press

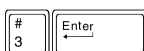

```
NORMAL SMOKE (PHOTO) DETECTOR ADDR 101 Z03 Z Z Z Z 000%A5 PA:0 ** D101
NORMAL SMOKE (ION) DETECTOR ADDR 102 Z02 Z Z Z Z 00%A5 PA:0 ** D102
NORMAL HEAT (ANALOG) DETECTOR ADDR 103 Z01 Z Z Z Z 000%A5 PA:0 * D103
OFF CONTROL MODULE ADDRESS 149 Z00 Z Z Z Z 052% IS* M149
NORMAL MONITOR MODULE ADDRESS 150 Z06 Z Z Z Z M150
```

View the History Buffer

From the Read Status menu, select History-Step, option **4**. This option lets you step through the history buffer one event at a time:

Press

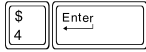

The first line that appears displays the number of events in the history buffer.

```
EVENT History Start           Events in HIST:005
```

Note:

Press  to scroll forward through the history buffer.

Press  to scroll back through the history buffer.

Step through the history buffer one event at a time by pressing the Next (F5) or Prior (F6) function keys.

Send the History Buffer to the CRT-2

From the Read Status menu, select History-All, option **5**. This option sends the entire history buffer to the CRT-2, from most recent event to oldest event:

Press

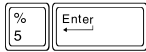

Most recent event

Semicolon

```
***** EVENT HISTORY*****
                ALL SYSTEMS NORMAL 04;15P Tue 08/01/95
SYSTEM RESET             04;15P Tue 08/01/95
ALARM SILENCED           04;15P Tue 08/01/95
ACKNOWLEDGE              04;14P Tue 08/01/95
ALARM: PULL STATION MODULE ADDRESS 151 Zone 06    04;14P 08/01/95 M151
***** PRINT END *****
```

The semicolon, a control character in networking applications, separates the hour and minute of events displayed from history. If events display as they occur, a colon separates the hour and minute.

Using the CRT-2 for Alter Status

Overview

This section shows how to do Alter Status functions, Table E-5, from a CRT-2.

Function	Lets you...
Disable	Enable or disable detectors, modules, or panel circuits.
Alarm/Pre-alarm	Change the Alarm and pre-Alarm levels of any addressable detector in the system.
Clear Verification	Clear the verification counter for all the addressable detectors in the system.
Clear History	Clear the contents of the history buffer.
Set Action/Alert	Set the pre-Alarm for the Alert or Action.

Table E-5 Alter Status Functions

Accessing Alter Status Options

Access the Alter Status function from the CRT-2 by following these steps.

1. Turn on the CRT-2 connected to the control panel.
2. Press the Alter Status function key. The control panel displays the Alter Status menu options:

Press



```
Enter Status Change Password or Escape to Abort
```

3. Enter the Status Change Password. The factory default Status Change Password is 11111. The password does not display on the CRT-2. Five asterisks will appear in place of the password:

Press



```
*****
```

The Alter Status Options menu appears:

```
1=Disable 2=Alarm/Prealarm 3=Clear Verification 4=Clear History 5=Alert/Action
```

From the Alter Status Options menu, you can select options 1-5.

Enable or Disable Detectors, Modules, or Panel Circuits

From the Alter Status menu, select Disable, option 1. Disable lets you enable or disable detectors, modules, panel circuits, or zones:

Press

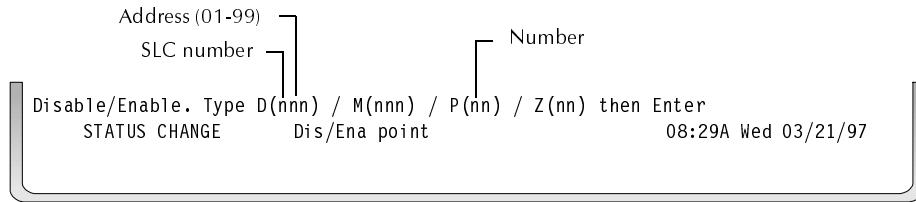

Enter the following:

1. Enter the first letter to read one of the following:
 - Detector
 - Module
 - Panel Circuit
 - Zone
2. Enter the address or number of the device.
3. Press <Enter> and a display similar to the following will appear.

Example Disable Detector address 01 on SLC1:

Press

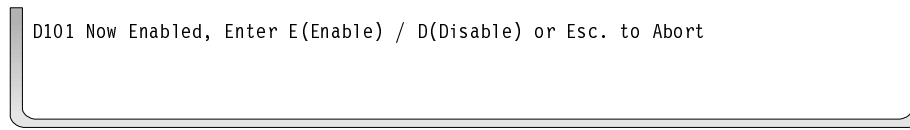

4. Press <E> to Enable or press <D> to Disable; then press <Enter>:

Press

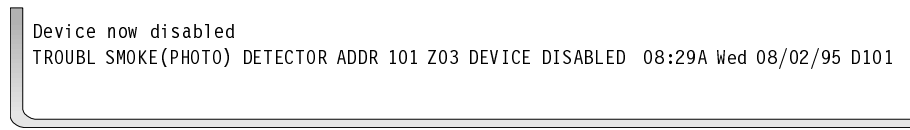

Change Alarm and Pre-Alarm levels

This option lets you change the Alarm and Pre-Alarm levels of any addressable detector in the system. To do so, follow these steps.

1. From the Alter Status menu, select option 2, Alarm/Pre-Alarm:

Press



```
Det. Alarm/Prealarm level, type address D(nnn), then Enter
STATUS CHANGE Alarm/Prealarm level 09:53A Wed 03/21/97
```

2. Enter the address of the detector you wish to change. For example, change alarm and Pre-Alarm levels for detector 102:

Press



```
STATUS CHANGE Alarm/Prealarm level 09:53A Wed 03/21/97
D102 sens. at level 5, Prealarm at level 3, Enter AxPx to change, Esc. to Abort
D102 now set at new Alarm level 5 and new Pre-alarm level 2
```

Clear the Verification Counter

Clear Verification lets you clear the verification counter for all the addressable detectors in the system:

Press

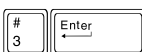

```
STATUS CHANGE Clear verify count 09:37A Wed 03/21/97
```

Clear the Entire History Buffer

Clear History lets you clear the entire history buffer:

Press



```
***** History Clear *****
```

Set the Pre-Alarm for Alert or Action

Set Action/Alert lets you set the Pre-Alarm for Alert or Action. For example, Change Pre-Alarm from “Alert” to “Action” as follows:

Press

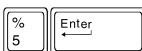

```
Set Pre-alarm Alert(NO)/Action(YES). Type N or Y then Enter
STATUS CHANGE Change Alert/Action 09:37A Wed 03/21/97
```

Press

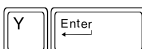

```
Pre-alarm now set for ACTION
```

Notes

Appendix F: UL Power-limited Wiring Requirements

Overview

Power-limited and nonpower-limited circuit wiring must remain separated in the cabinet. All power-limited circuit wiring must remain at least 0.25 inches from any nonpower-limited circuit wiring. All power-limited and nonpower-limited circuit wiring must enter and exit the cabinet through different knockout and or conduits.

Power-limited Modules and Circuits

Note: All nonpower-limited circuits connected to ADT-ACM-8R, ARM-4, CRM-4, CRE-4, and LDM-R32 modules must be identified in the space provided on the cabinet door label.

Table F-1 lists all power-limited modules and circuits compatible with the control panel:

Power-limited Components	Include the following...		
Modules with power-limited circuits	ADT-ACM-16AT AEM-16AT ADT-ACM-32A AEM-32A ADT-AFM-16A ADT-AFM-16AT ADT-AFM-32A ACT-1 AMG-E	AMG-1 AMG-2 ADT-CPU-400 DCM-4 FFT-7 FFT-7S ICM-4 ICE-4 ADT-LCD-80	ADT-LDM-32 LDM-E32 ADT-NIB-96 ADT-RPT-485 UDACT ADT-UZC-256 VCE-4 VCM-4
Modules with nonpower-limited circuits	AA-30 AA-100 AA-120 AVPS-24 MPS-400 4XTM	AC and battery circuits are nonpower-limited Municipal Box circuit is nonpower-limited	
Circuits (dry contacts) on these modules when connected to power-limited sources	ADT-ACM-8R ARM-4 CRM-4 CRE-4 LDM-R32		

Table F-1 Power-limited Components

UL Power-limited Wiring Requirements

Figure F-1 shows a typical wiring diagram for the control panel. The first two rows show rows of modules configured with at least a 0.25 inch separation between power-limited and nonpower-limited wiring.

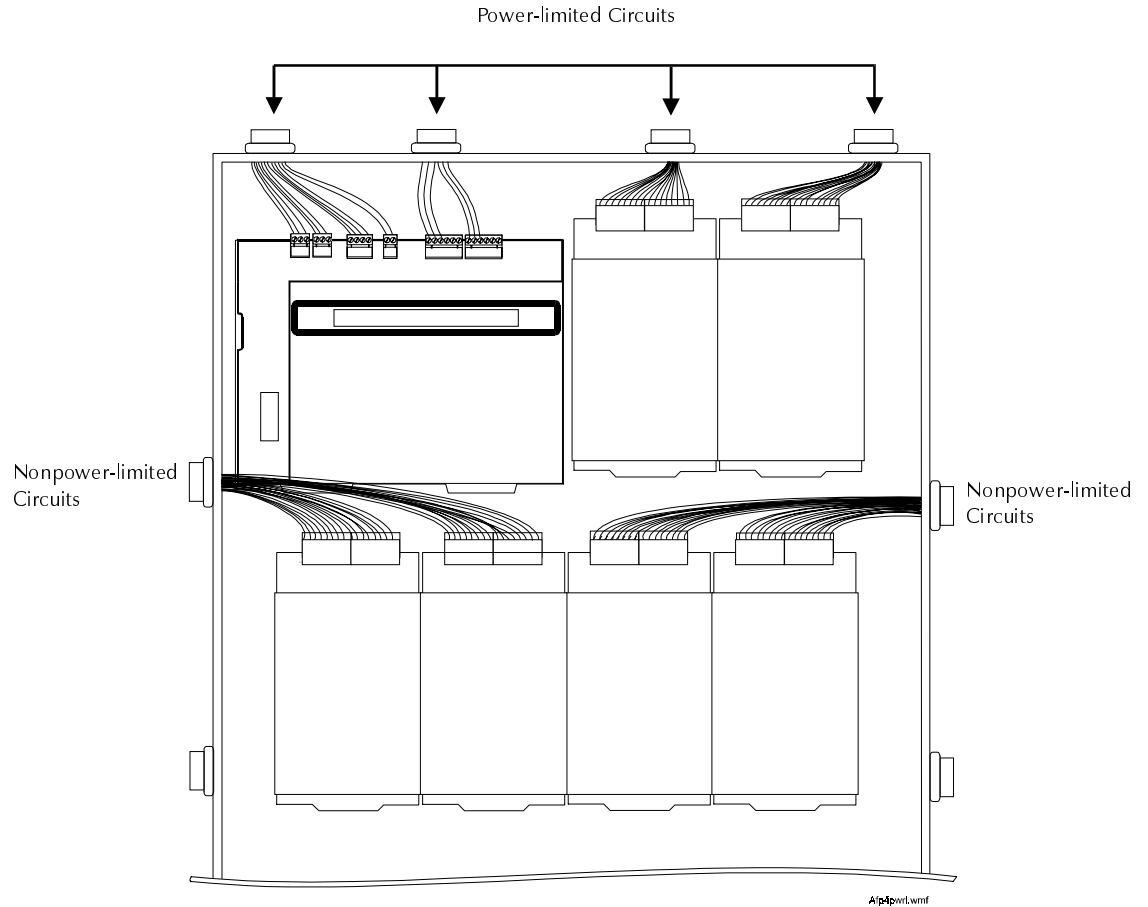

Figure F-1 Typical Wiring for UL Power-limited Wiring Requirements

Power Supply Wiring

AC and battery wiring are not power-limited. Maintain at least 0.25 inches between power-limited and nonpower-limited circuit wiring. Install tie wraps and adhesive squares to secure the wiring. Figure F-2 shows a typical wiring diagram for a power supply:

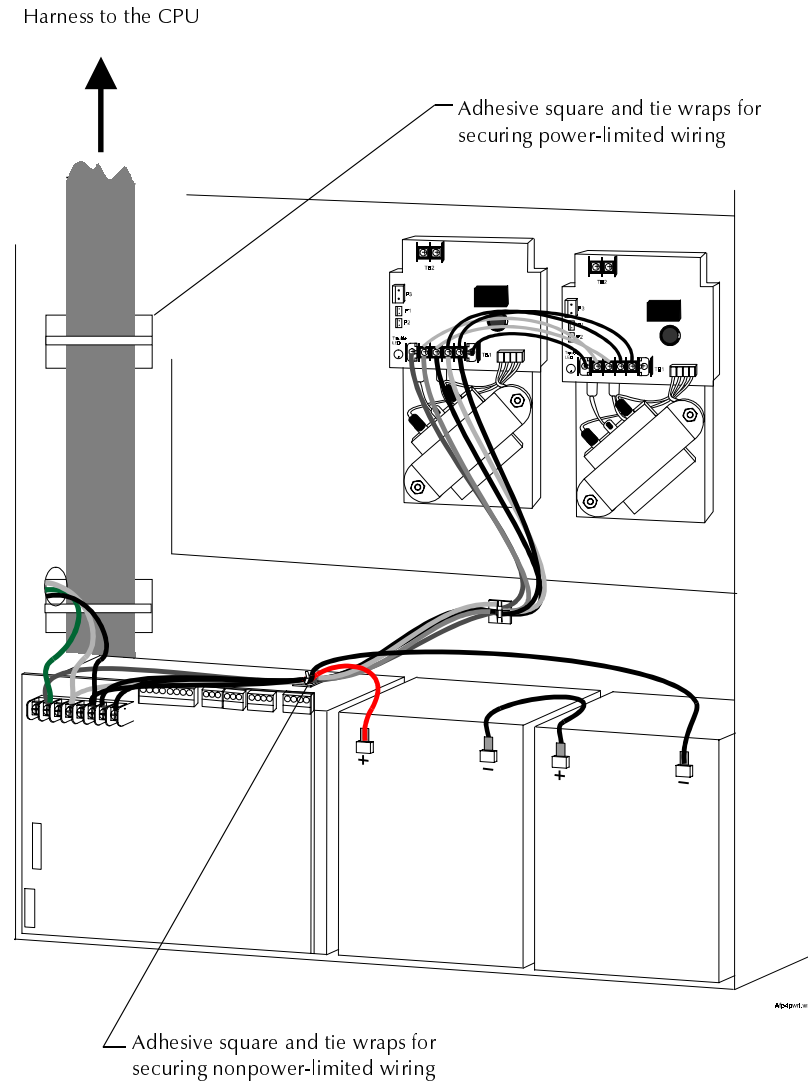

Figure F-2 Typical Power and Nonpower-limited Wiring for Power Supplies

Notes

Appendix G: Power Supply Calculations

Overview

Follow these guidelines when wiring the AC branch circuit current:

- The control panel requires connection to a separate dedicated AC fire alarm circuit, which must be labeled “Fire Alarm.”
- The AC power circuit must connect to the line side of the main power feed of the protected premises.
- Do not power other equipment from the AC fire alarm circuit.
- The AC power circuit wiring must run continuously, without any disconnect devices, from the AC power source to the control panel.
- Overcurrent protection for this circuit must comply with Article 760 of the National Electrical Code as well as local codes.
- Use 12 AWG wire with 600-volt insulation for the AC power circuit.

Calculating AC Branch Circuit Current

Use Table G-1 to determine the total amount of current, in AC amperes, that a 120 VAC, 50/60 Hz service must be able to supply to the fire alarm system. Devices rated for 240 VAC operation will draw one-half the current listed in Table G-2:

Device Type	No. of Devices		Current (amps)		Total Current
MPS-400	[1]	X	3.00	=	3
AVPS-24	[]	X	1.00	=	
AA-30	[]	X	1.00	=	
AA-120	[]	X	1.85	=	
R45-24 Remote Battery Charger	[]	X	1.0	=	
Sum column for AC Branch Current required=amps					

Table G-1 120 VAC Fire Alarm Circuit

Calculating the System Current Draws

The MPS-400 must be able to power all internal system devices (and several external types of devices) continuously during non-fire alarm conditions. Use column 1 in Table G-2 to calculate the Non-Fire Alarm Load on the MPS-400 regulator when applying primary power. The MPS-400 must provide a finite amount of additional current during a fire alarm condition. Use column 2 in Table G-2 to calculate the additional current needed during fire alarms. The requirements for non-fire alarm and fire alarm current loads cannot exceed the capabilities of the MPS-400 listed below:

- 3 A at 24 VDC during Standby; and
- 6 A at 24 VDC during Alarm.

How to Use Table G-2

Throughout these current calculation tables, “Primary” refers to the FACP primary source of AC power. “Secondary” refers to the FACP backup batteries (or any other 24 VDC uninterruptible, regulated power supply listed for Fire Protective Signaling and connected in place of the batteries).

Note: Table G-2 contains the following columns:

1 2 3

The Primary Power Source Non-Alarm Current and Alarm Current columns of Table G-2 are AC current calculations. These calculations confirm that the MPS-400 can supply enough current to support the system during Primary Non-Fire Alarm and Fire Alarm conditions.

Column 1 (Primary, Non-Fire Alarm Current in amps). Sum column 1 of Table G-2 to get the current drawn from the MPS-400 during a non-alarm condition, with AC power applied. This current draw cannot exceed 3 A.

Column 2 (Primary, Fire Alarm Current in amps). Calculation column 2 of Table G-2 lets the system designer determine the current load that the MPS-400 must support during a fire alarm. The total current drawn from the MPS-400 during a fire alarm cannot exceed 6 A.

Typically, a system should contain capacity to activate all output circuits and relays, and support fire alarms on no less than 10% of Initiating Device Circuits, subject to the requirements of the Authority Having Jurisdiction (AHJ).

- **If using four-wire detectors** In Table G-2, the primary fire alarm current for four-wire smoke detectors equals the manufacturer's rated fire alarm current minus the manufacturer's rated non-fire alarm current.
- **If using notification appliances** The MPS-400 provides a regulated supply for Notification Appliance Circuits, allowing the use of any 24 VDC notification appliances that are UL-listed for fire alarm systems.

Column 3 [Secondary (Battery) Non-Alarm Current]. Column 3 of Table G-2 lets the system designer calculate the secondary non-fire alarm current. (Non-fire equals the current drawn from the secondary source in a non-fire alarm condition during AC power loss.) The non-fire alarm current is required to complete the standby battery calculations. After summing all current draws, insert the total in Table G-3.

Note: No more than 6 A of current can be drawn from the MPS-400 during an alarm condition.

Category	Calculation Column 1 Primary, Non-Fire Alarm Current (amps)			Calculation Column 2 Primary, Fire Alarm Current (amps)			Calculation Column 3 Secondary, Non-Fire Alarm Current (amps)		
	Qty	X [current draw]=	Total	Qty	X [current draw]=	Total	Qty	X [current draw]=	Total
Basic System (CPU + MPS-400)	1	x [0.225] =	0.225	1	x [0.420] =	0.420	1	x [0.170] =	0.170
AVPS-24							[]	x [0.009]=	
ICM-4, CRM-4	[]	x [0.007]=		[]	x [0.072]=		[]	x [0.007]=	
ICE-4	[]	x [0.001]=		[]	x [0.065]=		[]	x [0.001]=	
CRE-4		N/A		[]	x [0.065]=		[]	N/A	
DCM-4	[]	x [0.008]=		[]	x [0.080]=		[]	x [0.008]=	
VCE-4	[]	x [0.001]=		[]	x [0.040]=		[]	x [0.001]=	
VCM-4	[]	x [0.007]=		[]	x [0.040]=		[]	x [0.007]=	
ADT-AFM-16AT, ADT-AFM-32A	[]	x [0.040]=		[]	x [0.056]=		[]	x [0.040]=	
ADT-ACM-16AT, ADT-ACM-32A	[]	x [0.040]=		[]	x [0.056]=		[]	x [0.040]=	
AEM-16AT, AEM-32A	[]	x [0.002]=		[]	x [0.018]=		[]	x [0.002]=	
ADT-AFM-16A	[]	x [0.025]=		[]	x [0.065]=		[]	x [0.025]=	
ADT-LCD-80,	[]	x [0.100]=		[]	x [0.100]=		[]	x [0.050]=	
ADT-ACM-8R (see Doc. A15342)	[]	x [] =		[]	x [] =		[]	x [] =	
ADT-LDM (see Doc. A15885)	[]	x [] =		[]	x [] =		[]	x [] =	
ADT-UZC-256	[]	x [0.035]=		[]	x [0.085]=		[]	x [0.035]=	
ADT-NIB-96	[]	x [0.022]=		[]	x [0.022]=		[]	x [0.022]=	
AMG-1, AMG-E, ATG-2	[]	x [0.060]=		[]	x [0.060]=		[]	x [0.060]=	
FFT-7, FFT-7S	[]	x [0.060]=		[]	x [0.120]=		[]	x [0.060]=	
AA-30							[]	x [0.045]=	
AA-100, AA-120							[]	x [0.050]=	
Two-Wire Smoke Detectors (refer to the Device Compatibility Document for current draws)	[]	x [] =		[]	x [] =		[]	x [] =	
	[]	x [] =		[]	x [] =		[]	x [] =	
	[]	x [] =		[]	x [] =		[]	x [] =	
	[]	x [] =		[]	x [] =		[]	x [] =	
RPT-W, RPT-WF, RPT-F	[]	x [0.017]=		[]	x [0.017]=		[]	x [0.017]=	
RPT-48 5W	[]	x [0.017]=		[]	x [0.017]=		[]	x [0.017]=	
RPT-48 5WF	[]	x [0.017]=		[]	x [0.017]=		[]	x [0.017]=	
1551/2551, 2551TH	[]	X [0.00020]=		[]	X [0.00020]=		[]	X [0.00020]=	
1251/2251	[]	X [0.00029]=		[]	X [0.00029]=		[]	X [0.00029]=	
M500M Series, ADT-BGX-501L	[]	X [0.00030]=		[]	X [0.00030]=		[]	X [0.00030]=	
M500CH (Note 5)	[]	X [0.0094]=		[]	X [0.0094]=		[]	X [0.0094]=	
B501BH (Horn in base)	[]	X [0.00100]=		[]	X [0.0150]=		[]	X [0.00100]=	
DH500, DH502	[]	X [] =		[]	X [] =		[]	X [] =	
M500X	[]	X [0.00045]=		[]	X [0.00045]=		[]	X [0.00045]=	
3251 (standard base)	[]	X [0.00031]=		[]	X [0.00031]=		[]	X [0.00031]=	
3251 (with B724RB)	[]	X [0.00043]=		[]	X [0.00043]=		[]	X [0.00043]=	
3251 (with B724BI)	[]	X [0.00056]=		[]	X [0.00056]=		[]	X [0.00056]=	
UDACT Communicator	[]	x [0.040]=		[]	x [0.100]=		[]	x [0.040]=	
Notification Appliance powered from MPS-400 (Note 1)				[]	x [] =				
				[]	x [] =				
Four-Wire Smoke Detectors (Note 2)	[]	x [] =		[]	x [] =		[]	x [] =	
	[]	x [] =		[]	x [] =		[]	x [] =	
Power Supervision Relay (A77-716B)	[]	x [0.020]=		[]	x [0.020]=		[]	x [0.020]=	
Other devices drawing power from MPS-400 TB2 excluding smoke detectors (Note 3)	[]	x [] =		[]	x [] =		[]	x [] =	
	[]	x [] =		[]	x [] =		[]	x [] =	
Remote Station Circuits	[]	x [0.018]=		[]	x [0.018]=		[]	x [0.018]=	
Sum each column for totals		Primary, non-alarm:			Primary, alarm:			Secondary, alarm:	

Table G-2 System Draw Current Calculations

Note: The following notes apply to Table G-2:

- For the MPS-400, enter the total notification appliance draw from the MPS-400, excluding the current from AVPS-24 supplies.
- The total regulated load current supplied to four-wire smoke detector and power supervision relays cannot exceed 1.25 A.
- TB2 on the MPS-400 TB2 contains three power outputs and the load on a power output cannot exceed 1.25 A.
- The total regulator load cannot exceed 6 A in alarm and 3 A in standby alarm current.
- Refer to Document M500-03-00 and the Device Compatibility Document.

Calculating the Maximum Secondary Power Fire Alarm Current Draw

Use Table G-3 to determine the maximum current requirements of secondary power source during fire alarm conditions. The result obtained from Table G-3 is the amount of current that the batteries must be able to supply to the fire alarm system. Use the result in Table G-4 to determine the size of the batteries needed for the fire alarm system.

Results taken from Table G-3 assume that, while in a fire alarm condition, batteries must feed the main power supply (and any additional supplies such as the AVPS-24 and AA-30) with the maximum rated power each supply can provide.

Note: The Secondary Fire Alarm Load cannot exceed the following:

- 9.0 A with PS-12120 batteries; and
- 12 A with PS-12250 or PS-12550 batteries.

On a system with a power supply having a small load, you can calculate the exact alarm current requirements of the secondary supply. To do so, add the secondary Non-Fire Alarm Load (from Table G-2) to the total fire alarm current draw of all notification appliances in the system. Use this value in Table G-4.

Device	No. in Alarm (Simultaneously)	Multiply by	Current (in amps)	Total Current/Type
MPS-400	1	X	6	6
AVPS-24	[]	X	3	
AA-30	[]	X	3	
AA-120	[]	X	7.3	
Sum Column for Secondary Fire Alarm Load =				

Table G-3 Maximum Secondary Power Fire Alarm Current Draw

Calculating the Battery Requirements

Calculating the Battery Capacity

Use Table G-4 to determine the battery capacity needed for the system:

Secondary Non-Fire Alarm (current from column 3 in Table G-2)	X	Required Secondary Non-Fire Alarm Standby Time (24 or 60 hours)	=	Non-Fire Alarm Secondary Amp Hours
Secondary Fire Alarm Load (from column 1 in Table G-2)	X	Required Fire Alarm Standby Time (for 5 minutes, enter 0.084; for 15 minutes, enter 0.25)	=	Secondary Fire Alarm Amp Hour Requirement
Sum Column for Total Secondary Amp Hours calculated =				
Multiply by the derating factor x 1.2 =				
Battery Size – Total Secondary Amp Hours Required				AH

Table G-4 Secondary Power Standby and Fire Alarm Load

The following notes apply to Table G-4:

1. NFPA 72 Local and Central Station systems require 24 hours of standby power followed by 5 minutes in alarm.
2. NFPA 72 Auxiliary and Remote Station Systems require 60 hours of standby power followed by 5 minutes in alarm.
3. Batteries installed in a system powered by an automatic starting engine generator need to provide at least 4 hours of standby power.
4. Factory Mutual requires 90 hours of standby for deluge-preaction systems.
5. Emergency voice/alarm communications systems require 2 hours of operation in the alarm condition. Due to the sporadic nature of voice operation, however, NFPA 72 permits 15 minutes of operation at a maximum connected load to equal 2 hours of normal use.
6. If the total exceeds 25 AH, the system requires a separate BB-55 battery enclosure for two PS-12550, 55 AH batteries. If the total exceeds 55 AH, an Uninterruptable Power Supply with sufficient amp-hour capacity is needed. The Uninterruptable Power Supply must be UL-listed for Fire-Protective Signaling.

Calculating the Battery Size

Use Table G-5 to sum the standby and alarm loads which determine the battery size, in amp-hours, needed to support the fire alarm system. Select batteries that meet or exceed the Total Amp-Hours calculated and that are within the acceptable battery charger range (12-55 AH). Write the amp-hours requirements on the Protected Premises label.

Battery Size	Voltage Rating	Number Required	Part Number	Cabinet Size
12 AH	12 volts	two	PS-12120	ADT-CAB-A3, B3, C3, D3
25 AH	12 volts	two	PS-12250	ADT-CAB-A3, B3, C3, D3
55 AH	12 volts	two	PS-12550	BB-55

Table G-5 Selecting the Battery Size

Notes

