

RP-1002M

AGENT RELEASE CONTROL PANEL

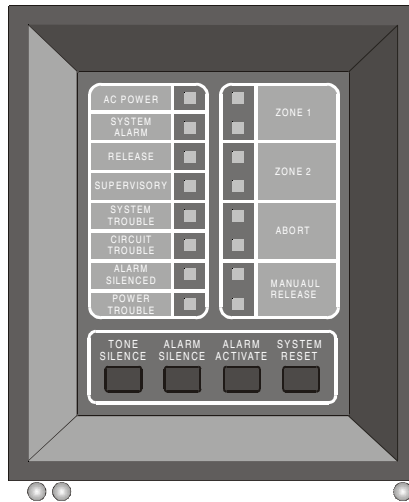

MODULAR PROTECTION®

Corporation

AUTOMATIC SUPPRESSION AND LIFE SAFETY SYSTEMS

Fire Alarm System Limitations

An automatic fire alarm system—typically made up of smoke detectors, heat detectors, manual pull stations, audible warning devices, and a fire alarm control with remote notification capability—can provide early warning of a developing fire. Such a system, however, does not assure protection against property damage or loss of life resulting from a fire.

The Manufacturer recommends that smoke and/or heat detectors be located throughout a protected premise following the recommendations of the current edition of the National Fire Protection Association Standard 72 (NFPA 72), manufacturer's recommendations, State and local codes, and the recommendations contained in the Guide for Proper Use of System Smoke Detectors, which is made available at no charge to all installing dealers. A study by the Federal Emergency Management Agency (an agency of the United States government) indicated that smoke detectors may not go off in as many as 35% of all fires. While fire alarm systems are designed to provide early warning against fire, they do not guarantee warning or protection against fire. A fire alarm system may not provide timely or adequate warning, or simply may not function, for a variety of reasons:

Smoke detectors may not sense fire where smoke cannot reach the detectors such as in chimneys, in or behind walls, on roofs, or on the other side of closed doors. Smoke detectors also may not sense a fire on another level or floor of a building. A second-floor detector, for example, may not sense a first-floor or basement fire.

Particles of combustion or "smoke" from a developing fire may not reach the sensing chambers of smoke detectors because:

- Barriers such as closed or partially closed doors, walls, or chimneys may inhibit particle or smoke flow.
- Smoke particles may become "cold," stratify, and not reach the ceiling or upper walls where detectors are located.
- Smoke particles may be blown away from detectors by air outlets.
- Smoke detectors may be drawn into air returns before reaching the detector.

The amount of "smoke" present may be insufficient to alarm smoke detectors. Smoke detectors are designed to alarm at various levels of smoke density. If such density levels are not created by a developing fire at the location of detectors, the detectors will not go into alarm.

Smoke detectors, even when working properly, have sensing limitations. Detectors that have photoelectronic sensing chambers tend to detect smoldering fires better than flaming fires, which have little visible smoke. Detectors that have ionizing-type sensing chambers tend to detect fast-flaming fires better than smoldering fires. Because fires develop in different ways and are often unpredictable in their growth, neither type of detector is necessarily best and a given type of detector may not provide adequate warning of a fire.

Smoke detectors cannot be expected to provide adequate warning of fires caused by arson, children playing with matches (especially in bedrooms), smoking in bed, and violent explosions (caused by escaping gas, improper storage of flammable materials, etc.).

While a fire alarm system may lower insurance rates, it is not a substitute for fire insurance!

Heat detectors do not sense particles of combustion and alarm only when heat on their sensors increases at a predetermined rate or reaches a predetermined level. Rate-of-rise heat detectors may be subject to reduced sensitivity over time. For this reason, the rate-of-rise feature of each detector should be tested at least once per year by a qualified fire protection specialist. *Heat detectors are designed to protect property, not life.*

IMPORTANT! Smoke detectors must be installed in the same room as the control panel and in rooms used by the system for the connection of alarm transmission wiring, communications, signaling, and/or power. If detectors are not so located, a developing fire may damage the alarm system, crippling its ability to report a fire.

Audible warning devices such as bells may not alert people if these devices are located on the other side of closed or partly open doors or are located on another floor of a building. Any warning device may fail to alert people with a disability or those who have recently consumed drugs, alcohol or medication. Please note that:

- Strobes can, under certain circumstances, cause seizures in people with conditions such as epilepsy.
- Studies have shown that certain people, even when they hear a fire alarm signal, do not respond or comprehend the meaning of the signal. It is the property owner's responsibility to conduct fire drills and other training exercise to make people aware of fire alarm signals and instruct them on the proper reaction to alarm signals.
- In rare instances, the sounding of a warning device can cause temporary or permanent hearing loss.

A fire alarm system will not operate without any electrical power. If AC power fails, the system will operate from standby batteries only for a specified time and only if the batteries have been properly maintained and replaced regularly.

Equipment used in the system may not be technically compatible with the control. It is essential to use only equipment listed for service with your control panel.

Telephone lines needed to transmit alarm signals from a premise to a central monitoring station may be out of service or temporarily disabled. For added protection against telephone line failure, backup radio transmission systems are recommended.

The most common cause of fire alarm malfunction is inadequate maintenance. To keep the entire fire alarm system in excellent working order, ongoing maintenance is required per the manufacturer's recommendations, and UL and NFPA standards. At a minimum, the requirements of Chapter 7 of NFPA 72 shall be followed. Environments with large amounts of dust, dirt or high air velocity require more frequent maintenance. A maintenance agreement should be arranged through the local manufacturer's representative. Maintenance should be scheduled monthly or as required by National and/or local fire codes and should be performed by authorized professional fire alarm installers only. Adequate written records of all inspections should be kept.

Installation Precautions

WARNING - Several different sources of power can be connected to the fire alarm control panel. Disconnect all sources of power before servicing. Control unit and associated equipment may be damaged by removing and/or inserting cards, modules, or interconnecting cables while the unit is energized. Do not attempt to install, service, or operate this unit until this manual is read and understood.

CAUTION - *System Reacceptance Test after Software Changes.* To ensure proper system operation, this product must be tested in accordance with NFPA 72 Chapter 7 after any programming operation or change in site-specific software. Reacceptance testing is required after any change, addition or deletion of system components, or after any modification, repair or adjustment to system hardware or wiring.

All components, circuits, system operations, or software functions known to be affected by a change must be 100% tested. In addition, to ensure that other operations are not inadvertently affected, at least 10% of initiating devices that are not directly affected by the change, up to a maximum of 50 devices, must also be tested and proper system operation verified.

This system meets NFPA requirements for operation at 0-49° C/32-120° F and at a relative humidity of 85% RH (non-condensing) at 30° C/86° F. However, the useful life of the system's standby batteries and the electronic components may be adversely affected by extreme temperature ranges and humidity. Therefore, it is recommended that this system and all peripherals be installed in an environment with a nominal room temperature of 15-27° C/60-80° F.

Verify that wire sizes are adequate for all initiating and indicating device loops. Most devices cannot tolerate more than a 10% I.R. drop from the specified device voltage.

Adherence to the following will aid in problem-free installation with long-term reliability:

Like all solid state electronic devices, this system may operate erratically or can be damaged when subjected to lightning-induced transients. Although no system is completely immune from lightning transients and interferences, proper grounding will reduce susceptibility. *Overhead or outside aerial wiring is not recommended, due to an increased susceptibility to nearby lightning strikes.* Consult with the Technical Services Department if any problems are anticipated or encountered.

Disconnect AC power and batteries prior to removing or inserting circuit boards. Failure to do so can damage circuits.

Remove all electronic assemblies prior to any drilling, filing, reaming, or punching of the enclosure. When possible, make all cable entries from the sides or rear. Before making modifications, verify that they will not interfere with battery, transformer, and printed circuit board location.

Do not tighten screw terminals more than 9 in-lbs. Over-tightening may damage threads, resulting in reduced terminal contact pressure and difficulty with screw terminal removal.

Though designed to last many years, system components can fail at any time. This system contains static-sensitive components. Always ground yourself with a proper wrist strap before handling any circuits so that static charges are removed from the body. Use static-suppressive packaging to protect electronic assemblies removed from the unit.

Follow the instructions in the installation, operating, and programming manuals. These instructions must be followed to avoid damage to the control panel and associated equipment. FACP operation and reliability depend upon proper installation by authorized personnel.

FCC Warning

WARNING: This equipment generates, uses, and can radiate radio frequency energy and if not installed and used in accordance with the instruction manual, may cause interference to radio communications. It has been tested and found to comply with the limits for class A computing device pursuant to Subpart B of Part 15 of FCC Rules, which is designed to provide reasonable protection against such interference when operated in a commercial environment. Operation of this equipment in a residential area is likely to cause interference, in which case the user will be required to correct the interference at his own expense.

Canadian Requirements

This digital apparatus does not exceed the Class A limits for radiation noise emissions from digital apparatus set out in the Radio Interference Regulations of the Canadian Department of Communications.

Le présent appareil numérique n'émet pas de bruits radioélectriques dépassant les limites applicables aux appareils numériques de la classe A prescrites dans le Règlement sur le brouillage radioélectrique édicté par le ministère des Communications du Canada.

NFPA Standards

This control panel complies with the following NFPA standards:

- **NFPA 12** - CO2 Extinguishing Systems (High Pressure Only)
- **NFPA 12A** - Halon 1301 Extinguishing Systems
- **NFPA 12B** - Halon 1211 Extinguishing Systems
- **NFPA 72 - Central Station Signaling Systems** (Automatic, Manual, and Waterflow) - Protected Premises Unit
Requires NOTI-FIRE 911AC DACT or 411UDAC Universal Digital Alarm Communicator
- **NFPA 72 - Local Fire Alarm Systems** (Automatic, Manual, Waterflow and Sprinkler Supervisory)
- **NFPA 72 - Auxiliary Fire Alarm Systems** (Automatic, Manual, and Waterflow)
Requires 4XTMF
- **NFPA 72 - Remote Station Fire Alarm Systems** (Automatic, Manual, and Waterflow)
Requires 4XTMF or NOTI-FIRE 911AC DACT or 411UDAC
- **NFPA 72 - Proprietary Fire Alarm Systems** (Automatic, Manual, and Waterflow)
Requires Potter EFT-C McCulloh Transmitter.
- **NFPA 2001** - Clean Agent Fire Extinguishing Systems

Note: Applications which require the NOTI-FIRE 911AC, or the Potter EFT-C are not FM approved.

Before proceeding, the installer should be familiar with the following documents.



NFPA Standards

- NFPA 72 - Automatic Fire Detectors
- NFPA 72 - Installation, Maintenance, and Use of Notification Appliances for Fire Alarm Systems
- NFPA 72 - Testing Procedures for Signaling Systems
- NFPA - 2001 Clean Agent Fire Extinguishing Systems



Underwriters Laboratories Documents

- UL 38 - Manually Actuated Signaling Boxes
- UL 217 - Smoke Detectors, Single and Multiple Station
- UL 228 - Door Closers - Holders for Fire Alarm Systems
- UL 268 - Smoke Detectors for Fire Alarm Systems
- UL 268A - Smoke Detectors for Duct Applications
- UL 346 - Waterflow Indicators for Fire Protective Signaling Systems
- UL 464 - Audible Signaling Appliances
- UL 521 - Heat Detectors for Fire Protective Signaling Systems
- UL 864 - Standard for Control Units for Fire Alarm Systems
- UL 1481 - Power Supplies for Fire Protective Signaling Systems
- UL 1638 - Visual Signaling Appliances
- UL 1971 - Signaling Devices for the Hearing Impaired



- CAN/ULC-S524-M91 Standard for Installation of Fire Alarm Systems
- CAN/ULC-S527-M87 Standard for Control Units for Fire Alarm System

Other

- NEC Article 300 - Wiring Methods
- NEC Article 760 - Fire Protective Signaling Systems
- Applicable Local and State Building Codes
- Requirements of the Local Authority Having Jurisdiction
- Fire-Lite Device Compatibility Document, 15384.
- ADA - Americans with Disabilities Act

Table of Contents

NFPA Standards	4
NFPA Standards	4
Underwriters Laboratories Documents	4
Other.....	4
1. Product Description	
Overview	7
Features	7
Options	7
Circuits	8
Input Circuits.....	8
Output circuits.....	8
Front Panel Control Switches	8
Supplemental Documentation	8
Control Panel	9
DIP Switch Functions	10
Options	10
Transmitter Module - 4XTMF	10
Zone Relay Module - 4XZMF	11
Remote Annunciator - RZA-4XF	11
LED Interface Module - 4XLMF	11
Specifications	13
AC Power.....	13
Battery (lead acid only).....	13
Initiating Device Circuits	13
Notification Appliance and Releasing Circuits.....	13
Alarm and Trouble Relays	13
Resettable Power.....	13
Nonresettable Power	13
RMS Regulated Power.....	13
2. Installation	
Cabinet Mounting	15
Removal of Circuit Board	15
Mounting of Cabinet	15
Attaching Conduit.....	15
Reinstallation of Circuit Board	16
Installing Optional Voltmeter/Ammeter	17
Power Connections	18
AC Connections	18
Battery (DC) Connections.....	18
Power-limited Wiring Requirements	19
Initiating Device Circuits	20
Four-Wire Smoke Detector Connections	21
Output Circuits	22
Notification Appliance Circuits	22
Releasing Circuits	23
Alarm Relay Circuit	24
Trouble Relay Circuit.....	24
Powering External Devices	24
Optional Modules	25
Overview	25
Installation - Upper Position	25
Installation - Lower Position.....	26
Setup and Configuration	27

Table of Contents

Transmitter Module - 4XTMF 27
Zone Relay Module - 4XZMF 28
LED Interface Module - 4XLMF 29
Setting Mode of Operation 30
 DIP Switch Functions..... 30
 Switch #1 - Cross Zone 30
 Switch #2 - Supervisory/Releasing Service 31
 Switch #3 and #4 - Timer Delay 31
 Switch # 5 and #6 - Abort Function..... 31
 Zone Relay Module Configuration 32
Power-Up Procedure 33

3. System Operation

System Status LEDs 35
Control Switches 36
Zone Status LEDs 36
Piezo 37
Supervisory Service 37
Zone Disable 37
Last Event Recall..... 38
Non-Silenceable Service 38
Sprinkler Supervisory Tracking 38
System Events 38
 Standby Condition..... 38
 System Trouble Condition 38
 Single Zone in Alarm (Cross Zone) Condition 39
 Both Zones in Alarm (Cross Zone) Condition 39
 Manual Discharge Station Alarm Condition 39
 Brownout Condition 39

Appendix A: Secondary Power Calculations

Standby Battery Requirements 41
Calculating the Battery Capacity..... 42

Appendix B: NFPA Standard-Specific Requirements

Minimum System Requirements 43
Additional Requirements..... 43
 NFPA 72 - Signaling Systems for Central Station Service
 (Protected Premises Unit) 43
 NFPA 72 - Auxiliary Fire Alarm System 43
 NFPA 72 - Remote Station Fire Alarm System 43
 NFPA 72 - Proprietary Fire Alarm System..... 43
Digital Alarm Communicator/Transmitter - Noti-Fire 911AC..... 44
Universal Digital Alarm Communicator - 411UDAC 45
Local Energy Municipal Box..... 46
Remote Station Receiver - RS82-9 47
Potter EFT-C McCulloh Transmitter 48

Appendix C: Testing & Maintenance

Testing 49
 Inspection 49
 Alarm Test..... 49
Maintenance 49
Troubleshooting..... 49

1. Product Description

Overview

The RP-1002M Agent Release Control Panel has been designed as a control center for use in automatic fire suppression systems. The panel is a feature-packed control unit suitable to perform detection and control functions associated with the release of gaseous agent/special hazard fire protection systems. The RP-1002M is designed for maximum reliability with 100% solid state circuitry and isolated relay contacts for outside interfacing and features programmable options to allow on-site customization of the unit for various operating configurations.

An integral standby battery system, with charger, is provided. In case of commercial AC power interruption, automatic switchover to the battery system will provide power to the panel for a minimum of 24 hours.

The FACP is supplied complete with backbox, hinged door, control switches, and indicator LEDs.

The entire unit is housed in a standard sheet-metal enclosure with 1/2 in. (12.7 mm) and 3/4 in. (19.05 mm) conduit knockouts available.

The RP-1002M is a 110/120 VAC agent release control panel.

Features

- Microprocessor-controlled
- Power-limited on all circuits except Municipal Box Output and Releasing Circuits
- Alarm and trouble resound
- Four Style B/D Initiating Device Circuits
- Two Style Y/Z Notification Appliance Circuits
- Two Style Y only Release Circuits
- General alarm and trouble relays
- Delay Timer (adjustable)
- Three abort function options
- Abort and manual release circuits
- Designed for suppression standards
- Disable/enable controls per Initiating Device Circuit
- Last Event Recall
- Battery /Earth fault supervision
- Current protection on all notification circuits
- RMS regulated output power, 2.25 amps
- 7 amp-hour (AH) to 18 AH battery options, up to 60 hours standby
- Resettable and nonresettable regulated power outputs
- Extensive transient protection
- Watchdog timer to supervise microprocessor
- Output circuits protected against false activations
- Slide-in zone identification labels
- Steel cabinet 14.5" (36.83cm) wide by 16.00" (40.64cm) high by 4.75" (12.07cm) deep

Options

- 4XZMF Module for 4 zone relays
- 4XTMF Transmitter Module - Complies with NFPA 72 Auxiliary and Remote Station Protective Signaling systems
- 4XMMF Volt/Amp Meter Module
- RZA-4XF Supervised remote annunciator (requires 4XLMF Interface Module)
- 411UDAC or NOTI•FIRE 911AC Digital Communicator - Complies with NFPA 72 Central Station and Remote Station Protective Signaling systems
- Potter EFT-C McCulloh Transmitter - Complies with NFPA 72 Proprietary Fire Alarm Systems
- Cross-zone option
- Supervisory Input option
- Dead-front dress panel option (DP-4XF) (Required for Canadian applications)
- Trim ring for flush mount between 16 in. (40.64 cm) center studs (TR-4XRF)

Note: Applications which require the 411UDAC, the NOTI-FIRE 911AC, or the Potter EFT-C are not FM approved.

Circuits

Input Circuits

Detector Zone 1 (Style B/D)

Detector Zone 2 (Style B/D)

Abort (Style B/D)

Manual Release (Style B/D)

Note: Optional auxiliary relay module 4XZMF tracks these four circuits.

Output circuits

Notification Appliance Circuit 1 (Style Y/Z)

Notification Appliance Circuit 2 (Style Y/Z)

Releasing Circuit 1 (Style Y)

Releasing Circuit 2 (Style Y) / Supervisory Input (StyleB)

Front Panel Control Switches

Switch 1 - Tone Silence

Switch 2 - Alarm Silence

Switch 3 - Alarm Activate

Switch 4 - System Reset

Supplemental Documentation

The table below lists document sources containing additional information regarding the RP-1002M:

For information on...	Refer to...	Part Number
Compatible Devices	Fire•Lite Device Compatibility Document	15384
Digital Alarm Communicator/Transmitters	NOTI-FIRE 911A & 911AC Instruction Manual 411UDAC Instruction Manual	74-06200-005 51073
Remote Station Receiver	Fire•Lite RS82-9 Instruction Manual	15400
Voltmeter/Ampmeter	4X Series Power Meter PID	15396

Control Panel

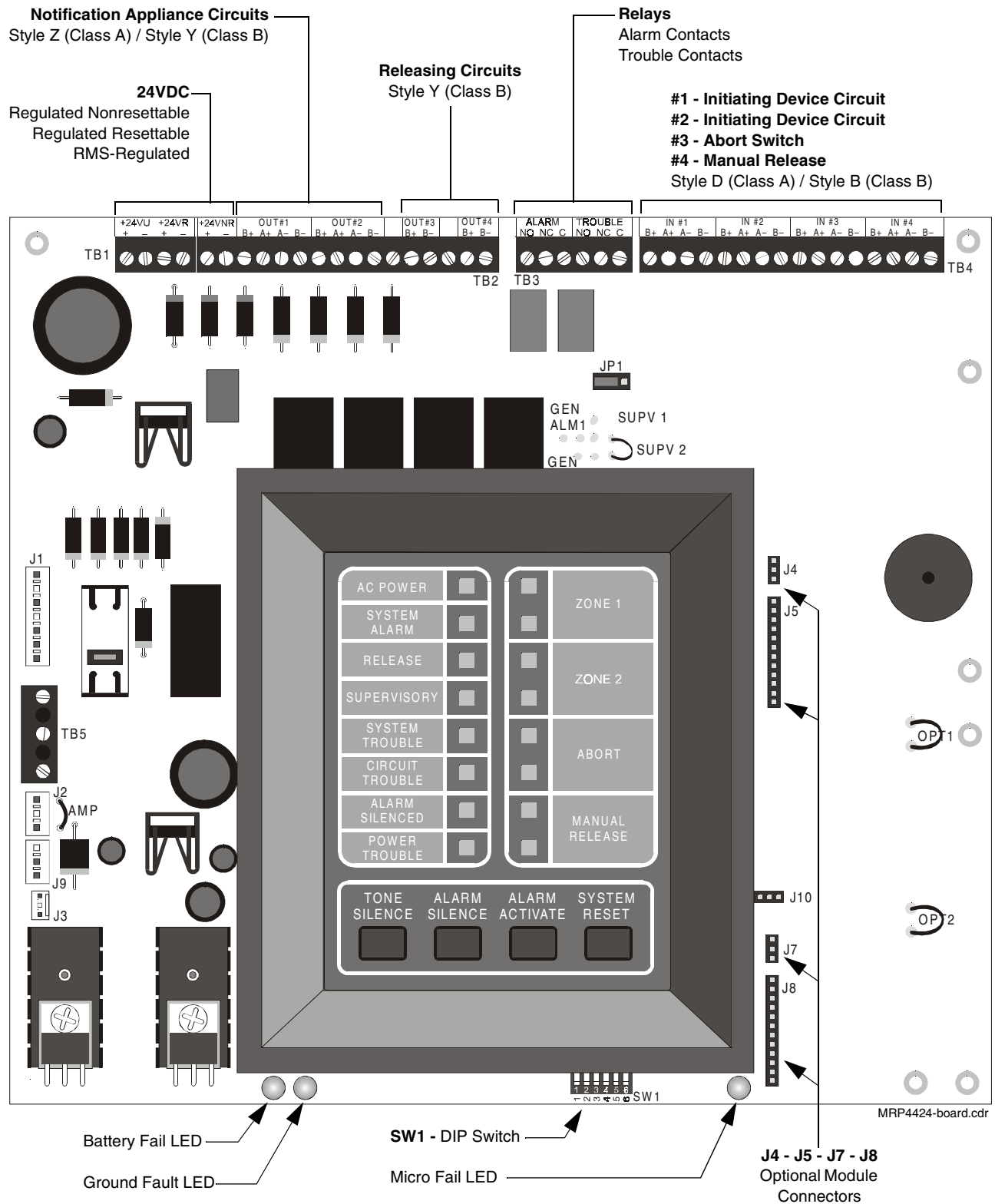

Figure 1 Control Panel

DIP Switch Functions

The table below describes the DIP switch functions. For a more detailed explanation see "Setting Mode of Operation" on page 30.

#1	Cross Zone	Determines how NACs and Releasing Circuits respond to an alarm.
#2	Supervisory	Selects Releasing Circuit #2 to function as a Supervisory Circuit.
#3 & #4	Timer	Selects Timer Delay setting.
#5 & #6	Abort	Selects a variety of abort functions.
Note: See "Setting Mode of Operation" on page 30 for a more detailed explanation of DIP switch functions.		

Options

Three optional modules are available for use on the control panel. The control panel provides mounting slots for two of these optional module boards.

Transmitter Module - 4XTMF

The Transmitter Module provides a supervised output for a Local Energy Municipal Box transmitter and alarm and trouble reverse polarity circuits for Remote Station Service. Also included is a DISABLE switch and disable trouble LED.

Note: As a jumper option, the alarm reverse polarity circuit will open on trouble if no alarm exists.

Specifications for Local Energy Municipal Box service (NFPA 72 Auxiliary Fire Alarm System)

- Supervisory current: 5.0 mA.
- Trip current: 0.35 amps (subtracted from Notification Appliance power).
- Coil Voltage: 3.65 VDC.
- Coil resistance: 14.6 ohms.
- Maximum allowable wire resistance between panel and trip coil: 3 ohms.
- Municipal Box wiring can leave the building.

Specifications for Remote Station Service (NFPA 72 Remote Station Fire Alarm System)

- Maximum load for each circuit: 10 mA.
- Reverse polarity output voltage: 24 VDC.
- Remote Alarm and Remote Trouble wiring can leave the building.

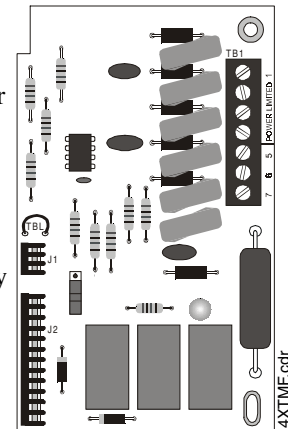

Zone Relay Module - 4XZMF

The Zone Relay module provides Form-C contacts for the following:

- Relay #1 - Alarm Detected / First Alarm
- Relay #2 - Alarm Detected / Second Alarm
- Relay #3 - Release 1 / Release 1
- Relay #4 - Release 2 / Not Used
- Relay #5 - General Alarm
- Relay #6 - System Trouble

Note: As a jumper option, the first four relays can be made silenceable.

Specifications

Dry Form-C contacts rated: 2.0 amps @ 30 VDC (resistive), 0.5 amps @ 30 VAC (resistive).

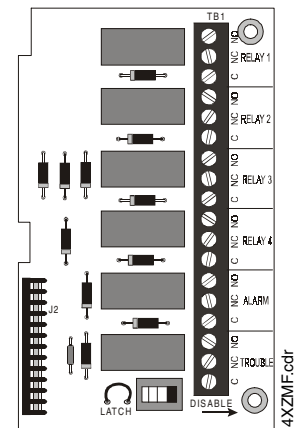

Remote Annunciator - RZA-4XF

The Remote Annunciator mounts on a standard single-gang box, and provides LED indication of the same functions as the zone relay module. For example, with DIP switch #1 'ON' and DIP switch #2 'OFF':

- One zone in alarm (red)
- Two zones in alarm (red)
- Releasing Circuit 1 (red)
- Releasing Circuit 2 (red)
- System Trouble (yellow)

A local trouble sounder and silence switch are also provided. All LED wiring is supervised for open conditions. Any open condition will cause the System Trouble LED to illuminate. Slide-in paper labels permit an easy change of zone information.

Note: The Remote Annunciator requires the use of an LED Interface Module as described below.

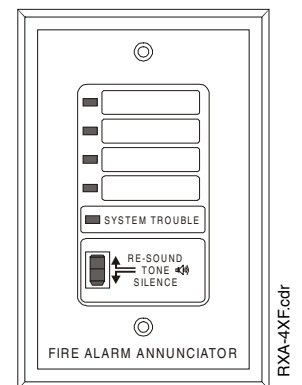

LED Interface Module - 4XLMF

The LED Interface Module supports the RZA-4XF Remote Annunciator Module. Annunciator wiring is supervised for open conditions by this module. The module mounts to the main board on the J8 option connector.

Specifications

Maximum voltage/current, each output: 27.6 V / 8 mA.
Outputs are power-limited.

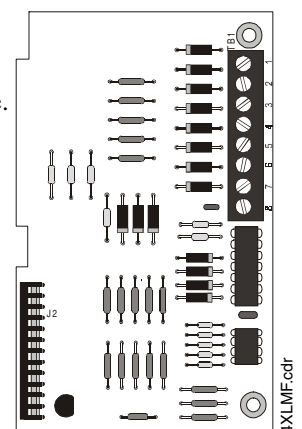

Meter Module (Volts-Amps) - 4XMMF

The Meter Module provides a voltmeter to measure the voltage across the batteries and an ammeter to measure the charging current to the batteries. The meters are provided as an assembly that mounts to the lower left-hand corner of the cabinet.

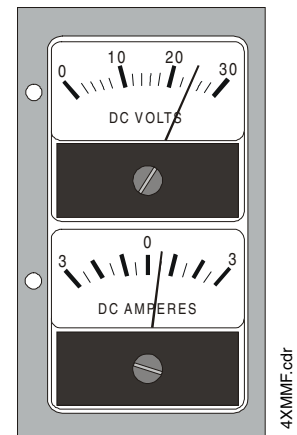

Specifications

AC Power

RP-1002M: 110/120 VAC, 50/60 Hz, 1.2 amps
Wire size: minimum #14 AWG with 600V insulation

Battery (lead acid only)

Maximum Charging Circuit: 27.6V, 1.5 amps
Maximum Battery Capacity: 18 AH.

Note: Batteries larger than 12 AH require Fire•Lite BB-17F or other UL-listed external battery cabinet.

Initiating Device Circuits

Power-limited circuitry

Operation: Style B (Class B) or Style D (Class A)
Normal Operating Voltage: 24 VDC (ripple = 1.0V p-p)
Alarm current: 15 mA minimum
Short circuit current: 40 mA maximum
Maximum detector current in standby: 2 mA (max) per zone
Maximum loop resistance: 100 ohms
End-of-Line Resistor: 4.7K, 1/2-Watt (part # 71252 UL listed)
Detector loop current is sufficient to ensure operation of one alarmed detector per zone.
Supervisory current: 5 mA (including End-of-Line Resistor)

Notification Appliance and Releasing Circuits

Power-limited circuitry

Maximum allowable voltage drop due to wiring: 2 VDC
Normal Operating Voltage: 24 VDC
Total current available to all external devices: 2.25 amps
Maximum signaling current per circuit: 1.5 amps
End-of-Line Resistor: 4.7K, 1/2-Watt (part # 71252 UL listed)

Alarm and Trouble Relays

Dry Form-C contacts rated: 2.0 amps @ 30 VDC (resistive), 0.5 amps @ 30 VAC (resistive).

Note: Any power connected to these relay contacts must come from a power-limited supply. Fail-safe operation ensures trouble relay functioning under loss of both primary power (AC) and secondary (battery power).

Resettable Power

Up to 200 mA is available for powering four-wire smoke detectors. Maximum ripple voltage: 1.0 V p-p.

Nonresettable Power

Total DC current available from this output is up to 200 mA (subtracted from four-wire smoke detector power). Maximum ripple voltage: 1.0 V p-p.

RMS Regulated Power

Total DC current available for powering external devices is 0.5 amp (subtracted from 2.25 amps available to Notification Appliance Circuits). Maximum ripple voltage: 100 mV p-p.

Notes

2. Installation

Cabinet Mounting

Carefully unpack the system and check for shipping damage.

Select a suitable location in a clean, dry, vibration-free environment that is not subject to extreme temperatures. Locate the top of the cabinet approximately five feet above the floor with the hinge on the left. The panel must be easily accessible for maintenance; the hinged door requires a minimum clearance of 14 in. (35.56cm) to open.

Removal of Circuit Board

To prevent damage to the printed circuit board it should be removed prior to mounting of cabinet.

Step	Action
1	Disconnect the transformer wires from the circuit board at the J1 connector.
2	Remove the four (4) phillips head screws securing circuit board to backbox rails.
3	Carefully set board aside in a secure place.

Mounting of Cabinet

Securely mount the cabinet using the mounting holes provided.

Step	Action
1	Mark and predrill holes for the top two keyhole mounting screws using the dimensions shown in Figure 2 on page 16.
2	Install two upper screws in the wall with the heads protruding.
3	Using the upper keyholes, mount the backbox over the two screws.
4	Mark and drill the lower two holes.
5	Secure backbox by installing the remaining fasteners and tightening all screws.
6	If required, attach optional Trim Ring (TR-4XRF) using the provided instructions.

Attaching Conduit

Select and remove knockouts according to the number of conduits required.

Attach conduits to backbox as required.

Determine the number of conductors required for the devices to be employed. Pull required conductors into the box through the knockouts provided.

Note: All wiring should be in accordance with the National and/or Local codes for fire alarm systems, including "Power-limited Wiring Requirements" on page 19.

The figure below shows the exterior dimensions and mounting hole locations for the cabinet backbox and dimensions of the optional trim ring:

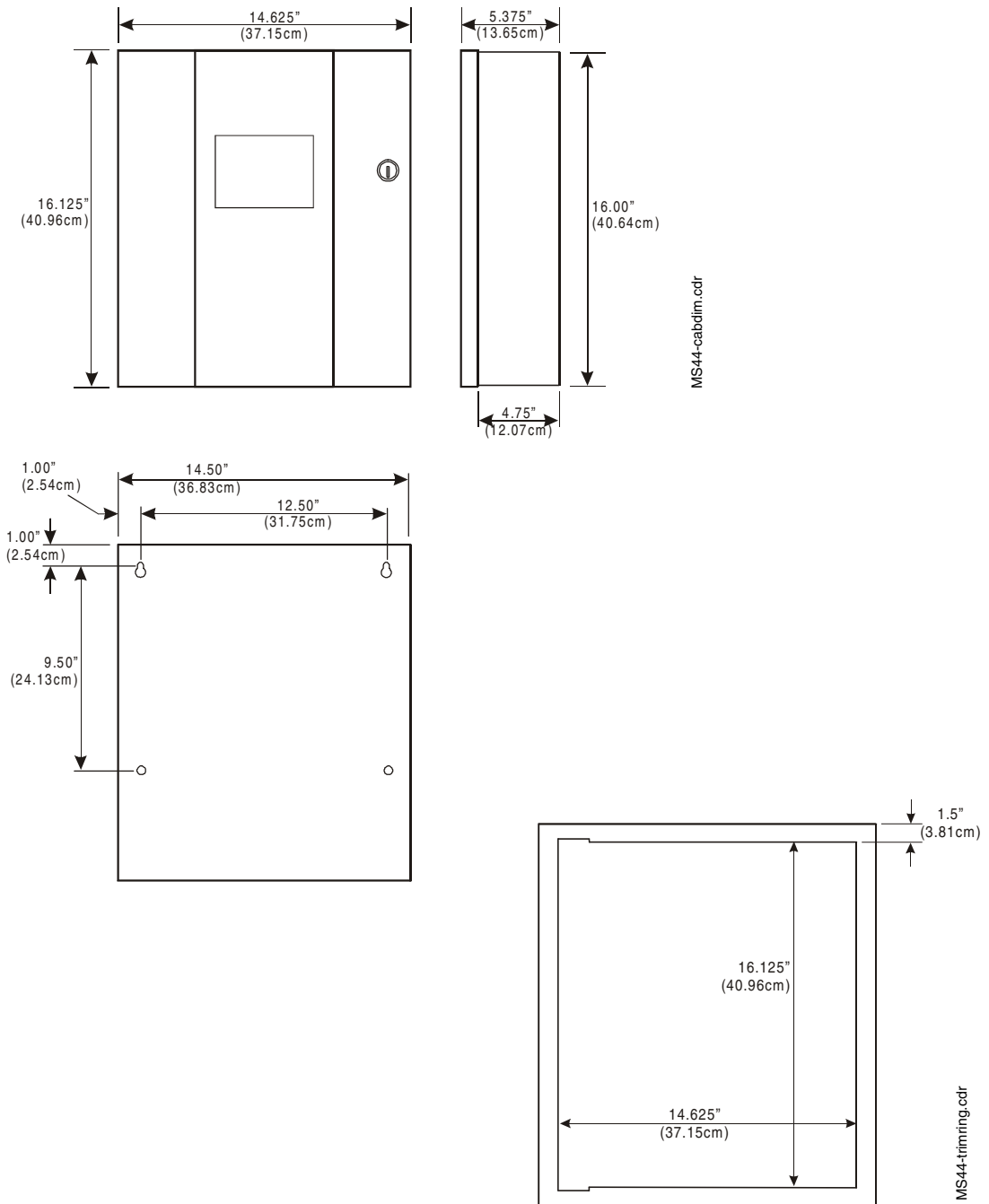

Figure 2 Cabinet Mounting Dimensions

Reinstallation of Circuit Board

Reinstall the printed circuit board as follows:

Step	Action
1	Position circuit board over stand-offs on backbox rail and secure with four (4) phillips screws. Tighten securely.
2	Connect transformer wires to J1 connector on circuit board.

Installing Optional Voltmeter/Ammeter

To monitor battery voltage and battery charging current, a 4XMMF Meter Module is required. To install the power meter module follow the steps below:

Step	Action
1	Cut the jumper wire labeled “AMP”.
2	Secure the module to the backbox with the hardware provided. Refer to Product Installation Drawing (PID) for detailed instructions.
3	Connect meter cable P2 to connector J2 on the main circuit board.
4	Connect meter cable P3 to connector J3 on the main circuit board.

The figure below shows the mounting location and connections for the Voltmeter/Ammeter.

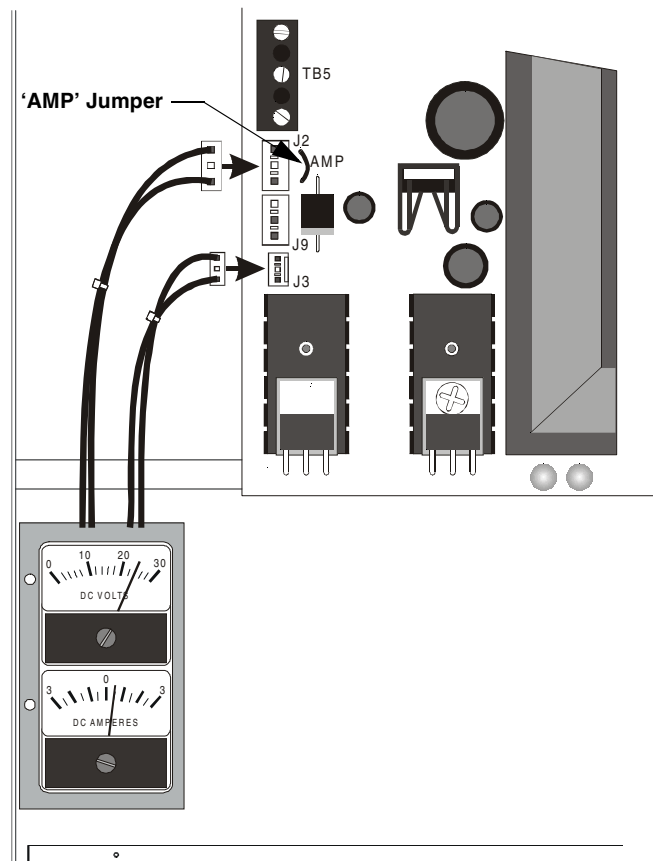

MS44-rminst.cdr

Figure 3 Mounting and Connecting the Meters

Power Connections



WARNING: Do not apply any type power to this control panel until all connections have been made and verified.

AC Connections

Disconnect (open) the circuit breaker in the AC main breaker panel and tag it "Out of Service".

Note: Refer to "Power-Up Procedure" on page 33 before closing AC breaker.

Primary power required for the RP-1002M control panel is 110/120 VAC, 50/60 Hz, 1.2 amps. Overcurrent protection for this circuit must comply with Article 760 of the National Electrical Code (NEC) and/or local codes. Use #14 AWG (2.00 mm²) or larger wire with 600V insulation rating.

A separately fused and protected power connection to the panel should be supplied to prevent voltage fluctuation and interruption of power.

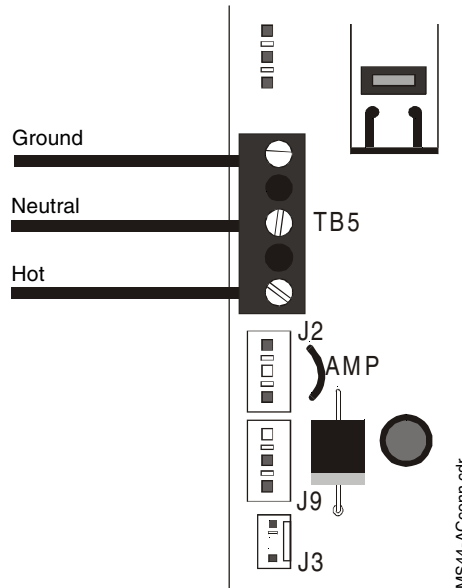

Figure 4 AC Power Connections

Battery (DC) Connections



WARNING: Battery contains sulfuric acid which can cause severe burns to the skin and eyes and can destroy fabrics. If contact is made with sulfuric acid, immediately flush the skin or eyes with water for 15 minutes and seek immediate medical attention.



CAUTION: Do NOT connect the battery interconnect wire at this time. Make this connection AFTER initial system primary power connection.

Place batteries into bottom of cabinet as shown below. See "Appendix A: Secondary Power Calculations" on page 41 for calculation of correct battery rating.

Note: Batteries are shipped separately and should be mounted only after the cabinet has been installed, the conduit connected, and all wiring pulled, tested, and made ready to be terminated.

Continued on the next page...

Observe polarity when connecting the batteries. Connect the battery cable (p/n 75203 or 75202, depending on terminal size of battery) to terminal J9 on the main circuit board using the plug-in connector provided. Connect red wire to positive (+) terminal and black wire to negative (-) terminal on opposing batteries. Do NOT connect battery interconnect wire at this time.

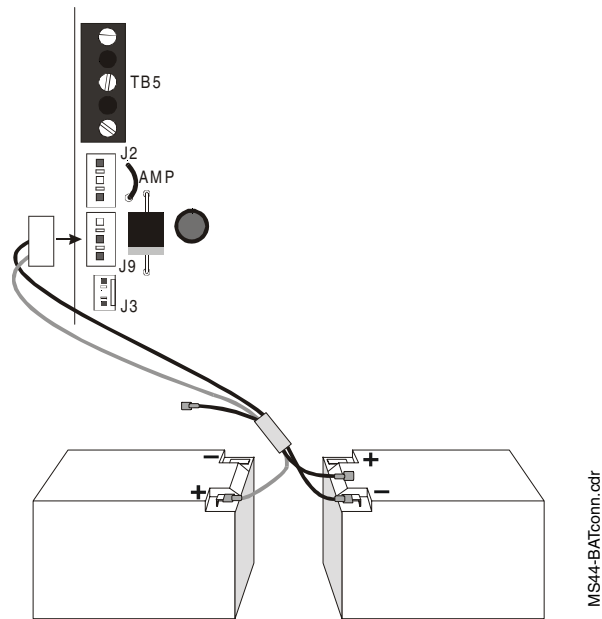

Figure 5 Battery Installation and Connection

Power-limited Wiring Requirements

Power-limited and nonpower-limited circuit wiring must remain separated in the cabinet. All power-limited circuit wiring must remain at least 0.25 in (6.35 mm) away from any nonpower-limited circuit wiring. Furthermore, all power-limited circuit wiring and nonpower-limited circuit wiring must pass through separate knockouts and/or conduits.

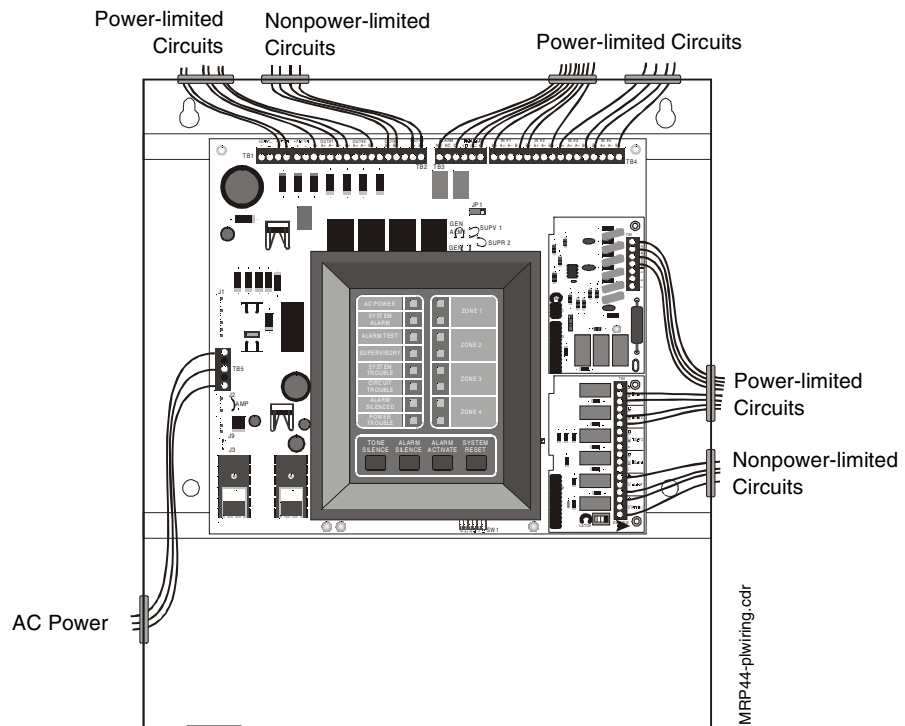

Figure 6 Power-limited Wiring Requirements

Initiating Device Circuits

The control panel provides two Initiating Device Circuits (#1 and #2) and they may be configured as either Style D (Class A) or Style B (Class B). Circuit #3 is designated as an Abort Switch Circuit and Circuit #4 is a Manual Release Circuit.

Initiating devices include: Heat, Photoelectric and Ionization type detectors, Manual Pull Stations and Waterflow alarm devices.

Note: Refer to the Device Compatibility Document for compatible devices.

- Wire all alarm initiating devices sequentially for proper supervision.
- Observe polarity when connecting polarized devices.
- All circuits are supervised and power-limited.
- Leave dummy load resistor (provided) on all unused circuits.

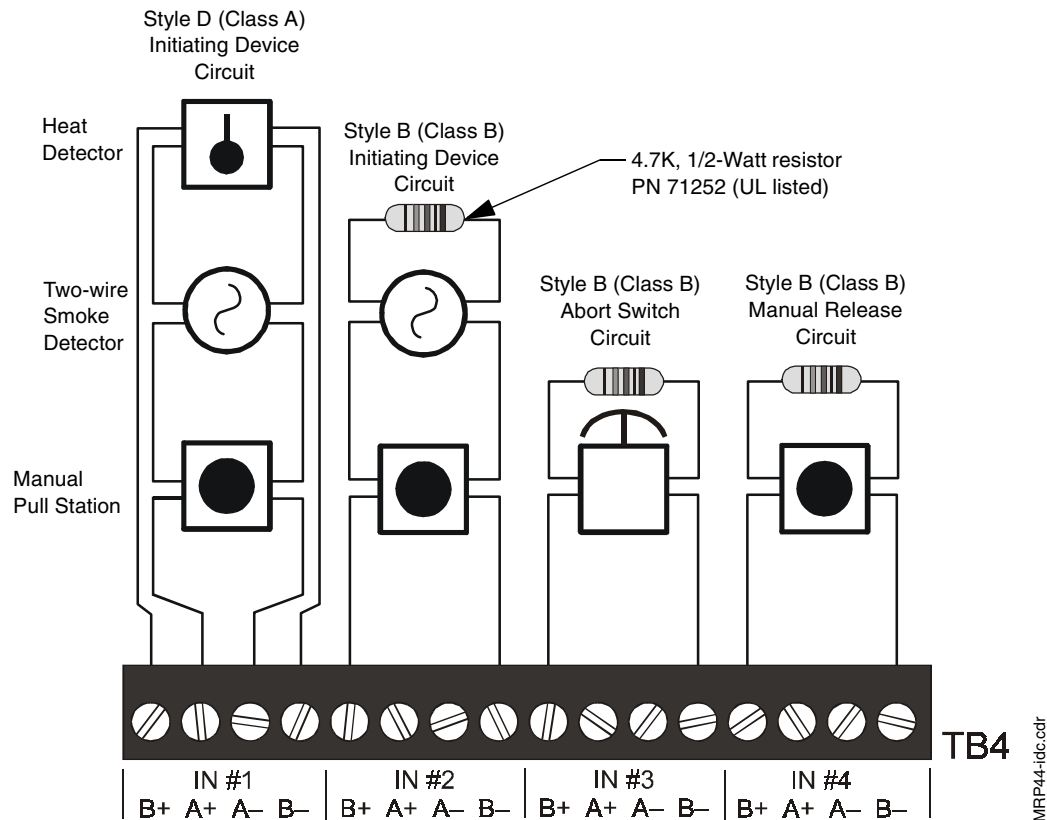

Figure 7 Initiating Device Circuits

Four-Wire Smoke Detector Connections

A maximum of 200mA is available from the 24VDC Resettable Power circuit on TB1 (+24VR terminals). Any power that is drawn from the 24VDC Nonresettable Power on TB2 (+24VNR terminal) must be subtracted from available resettable power. See "Specifications" on page 13 and "Powering External Devices" on page 24.

Note: Refer to the Device Compatibility Document for suitable 4-wire smoke detectors.

Notes on Style D (Class A) and Style B (Class B) field wiring:

1. The Power Supervision Relay coil leads must be connected to the last detector base 24V screw terminals.
2. Calculation of the maximum allowable resistance in the 24VDC resettable power wiring:

$$R_{max} = \frac{(20.6 - V_{om})}{(N \times I_s) + (N_a \times I_a) + (I_r)}$$

Where:

R_{max} = maximum resistance of the 24 VDC wires

V_{om} = minimum operating voltage of the detector or end-of-line relay, whichever is greater, in volts

N = total number of detectors on the 24 VDC supply circuit

I_s = detector current in standby

N_a = number of detectors on the 24 VDC power circuit which must function at the same time in alarm

I_a = detector current in alarm

I_r = end-of-line relay current

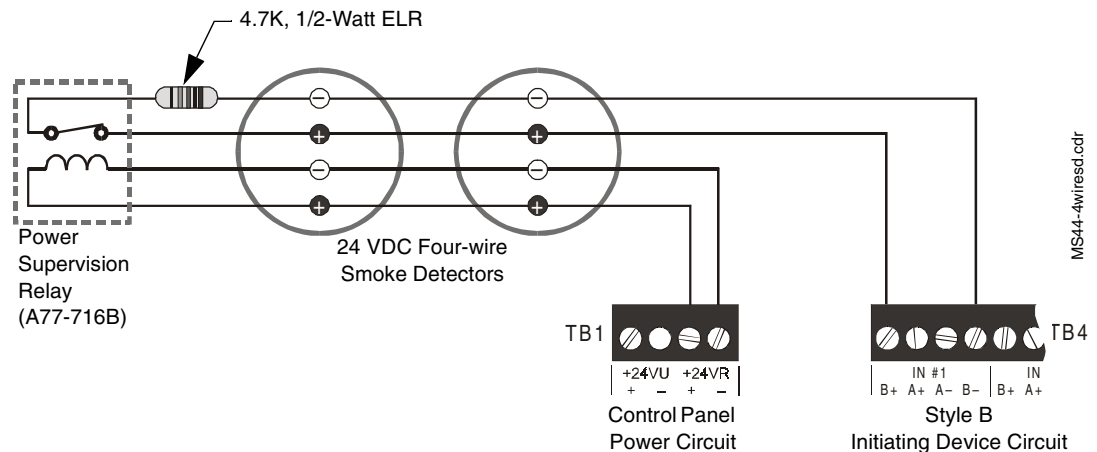

Figure 8 Typical Connection for Four-Wire Smoke Detectors

Output Circuits

Notification Appliance Circuits

The control panel provides two Style Z (Class A) or Style Y (Class B) Notification Appliance Circuits, which are supervised and power-limited.

Each circuit is capable of 1.5 amps of current. Total current drawn from both NACs and both Releasing Circuits (see "Releasing Circuits" on page 23) cannot exceed 2.25 amps.

Note: Refer to the Device Compatibility Document for suitable devices.

- For DIP switch configuration, see "Setting Mode of Operation" on page 30.
- For non-silenceable service on NAC#1, see "Non-Silenceable Service" on page 38.
- Unused circuits must be connected with a dummy load as shown.

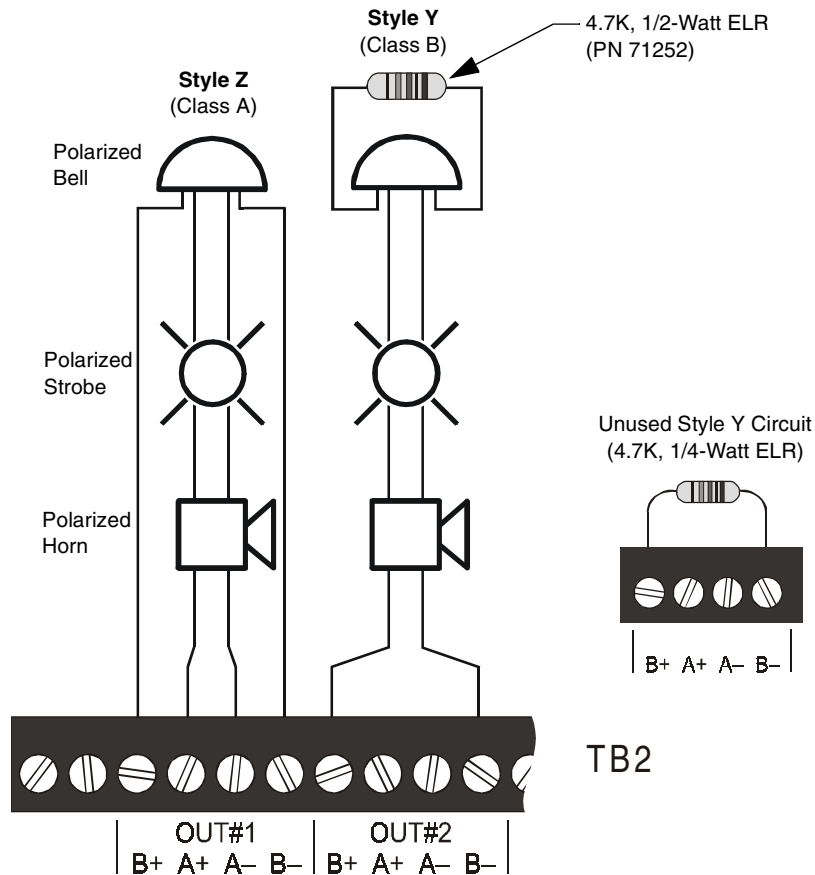

Figure 9 Notification Appliance Circuits

MRP44-nac.cdr

Releasing Circuits



CAUTION: To prevent accidental discharge, connect releasing devices after initial panel tests are completed.

The control panel provides two Style Y (Class B) Releasing Circuits, which are nonpower-limited.

Circuit #2 can be configured for a Supervisory Circuit (see "Setting Mode of Operation" on page 30) and will then be power-limited.

Note: All wiring must follow the requirements as specified under "Power-limited Wiring Requirements" on page 19.

Each circuit is capable of 1.5 amps of current. Total current drawn from both Releasing Circuits and both NACs (see "Notification Appliance Circuits" on page 22) cannot exceed 2.25 amps.

- UL listed and FM approved releasing devices must be used.
- Unused circuits must be connected with a dummy load as shown.

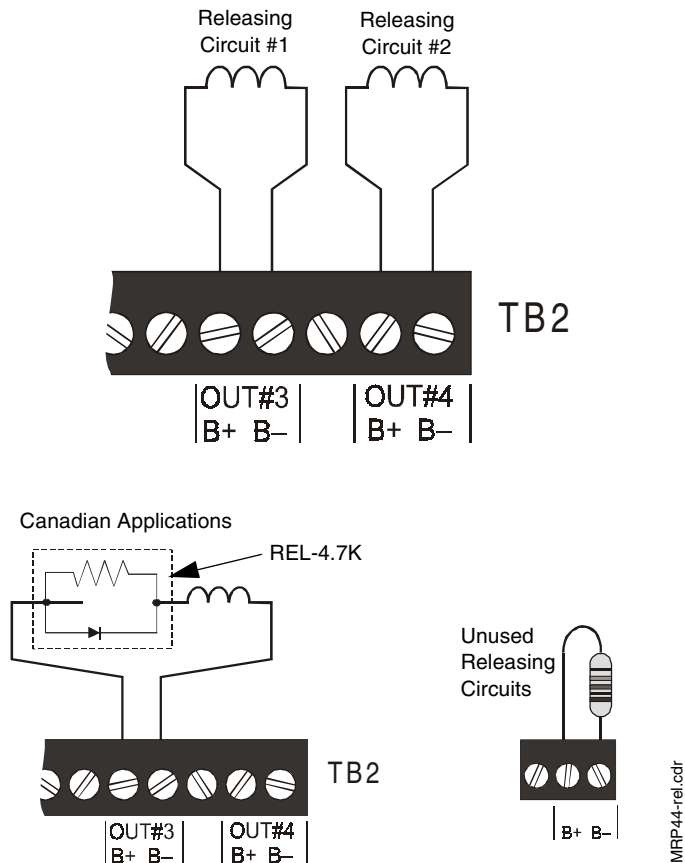

Figure 10 Releasing Circuits

Wiring must be configured to maintain a minimum voltage of 20.4 VDC on releasing Circuits. Calculation of maximum allowable resistance:

$$R_{max} = \frac{20.6 \text{ VDC} - 20.4 \text{ VDC}}{I_s}$$

Where:

R_{max} = maximum allowable resistance of wiring

I_s = Solenoid current

Alarm Relay Circuit

One Form-C dry contact alarm relay is provided in the basic panel for controlling supplementary devices. Contacts are rated 2 amps at 30 VDC and 0.5 amps at 30 VAC (resistive) and are non-silenceable when an alarm occurs.

Trouble Relay Circuit

One Form-C dry contact trouble relay is provided in the basic panel for controlling supplementary devices. It is rated 2 amps at 30 VDC and 0.5 amps at 30 VAC (resistive) and will restore to normal when the trouble condition is cleared.

Note: Power connected to these relay contacts must come from a power-limited supply. Power may be obtained from TB1 Terminals 24VU or 24VR and TB2 Terminals 24VNR, or a UL-listed power-limited power supply.

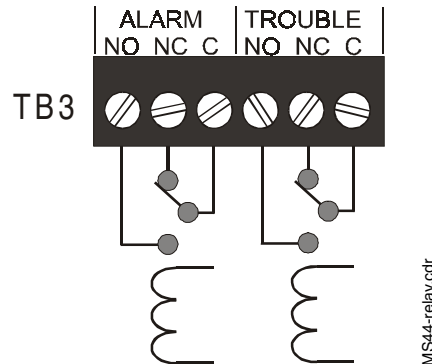

Figure 11 Schematic Representation of Alarm/Trouble Coils & Contacts

Powering External Devices



CAUTION: Several different sources of power can be connected to this panel. Disconnect all sources of power before servicing. The panel and associated equipment may be damaged by removing and/or inserting cards, modules, or interconnecting cables while this unit is energized.

DC power connections are available from TB1 and TB2 on the control panel as shown below:

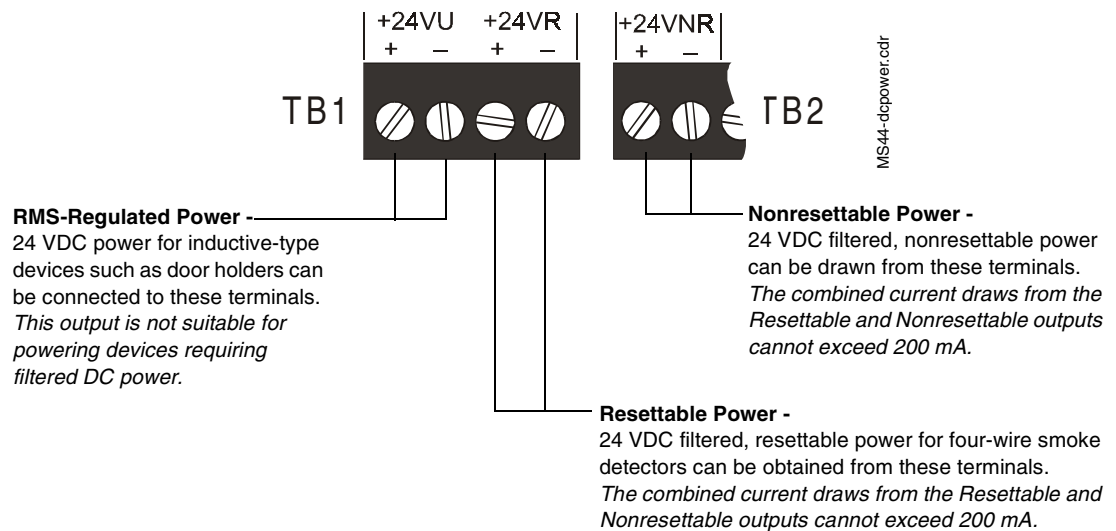

Figure 12 Power Terminals

Optional Modules

Overview

The control panel has two module connectors - J5 (upper position) and J8 (lower position). Three modules are available for the panel and they can be used in any combination, including duplicate modules. The corresponding option jumper must be cut before installation of an optional module, to enable module supervision.

- The 4XTMF Transmitter and 4XZMF Zone Relay Modules can be installed in either position.
- The 4XLMF Interface Module must be installed in the lower position only.

Installation - Upper Position

To install either the 4XTMF or 4XZMF module in the upper position follow these instructions:

Step	Action
1	Cut jumper 'OPT1' on main circuit board.
2	Insert the two stand-offs into the holes located on the right-side edge of the main board. Secure with nuts and tighten securely.
3	Align the pins of J5 (and J4) connectors on the main board with the holes on the underside of the J2 (and J1) connector on the optional board. Carefully press down on the optional board until the pins are through the connectors and it rests on the stand-offs.
4	Secure optional board to stand-offs with screws. Tighten securely.
5	Affix the terminal identification label (provided with the module) on the back surface of the backbox, aligning it with the terminals on the module.

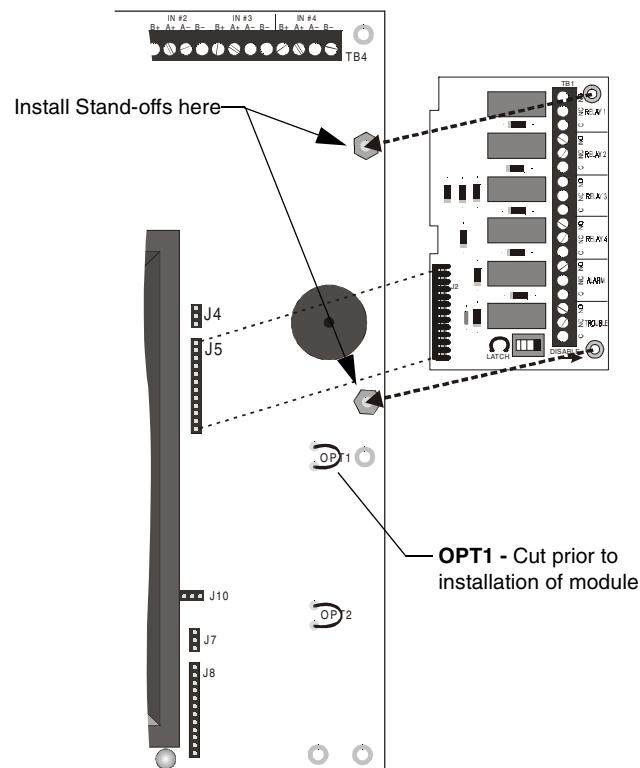

Figure 13 Module Installation - Upper Position

Installation - Lower Position

To install either the 4XTMF, 4XZMF or 4XLM module in the lower position follow these instructions:

Step	Action
1	Cut jumper 'OPT2' on main circuit board.
2	Remove the lower-right screw securing the main board to the lower rail. Replace with a stand-off and tighten securely.
3	Insert one stand-off into the other hole located on the right-side edge of the main board. Secure with nut and tighten securely.
4	Align the pins of J8 (and J7) connectors on the main board with the holes on the underside of the J2 (and J1) connector on the optional board. Carefully press down on the optional board until the pins are through the connectors and it rests on the stand-offs.
5	Secure optional board to stand-offs with screws. Tighten securely.
6	Affix the terminal identification label (provided with the module) on the back surface of the backbox, aligning it with the terminals on the module.

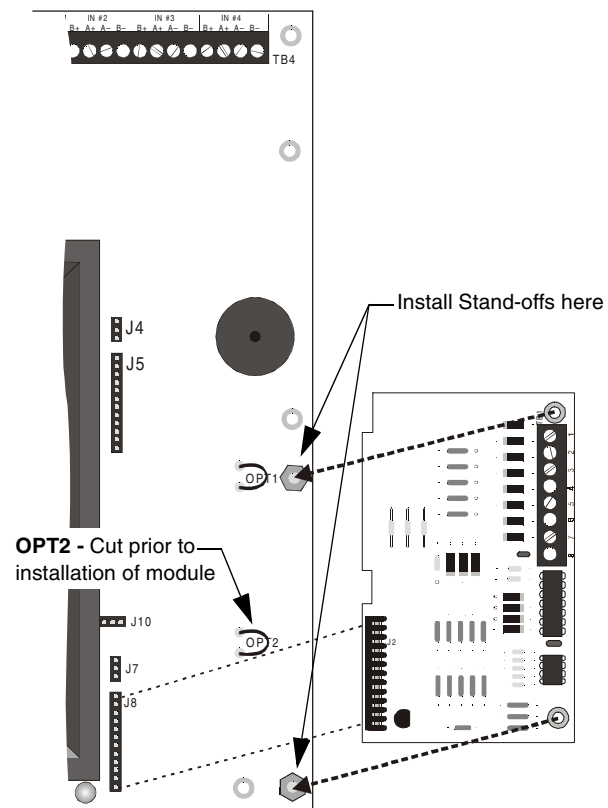

Figure 14 Module Installation - Lower Position

Setup and Configuration

Transmitter Module - 4XTMF

Connect a Remote Alarm circuit, Remote Trouble circuit or a Municipal Box to the Transmitter Module as shown below. Polarities shown in activated positions.

Note: Dummy load terminals 6 and 7 (4.7K, 1/4 W resistor) if Municipal Box is not connected.

Note: Remote Alarm, Remote Trouble and Municipal Box wiring can leave the building.

Pushing the Disconnect Switch down will prevent unwanted activation of the Municipal Box during testing of the control panel. The Disconnect LED will remain illuminated while the Municipal Box is disconnected. The System Trouble LED will indicate disconnected and/or Open Circuit conditions on the Municipal Box.

Cut the TBL Jumper to allow the alarm reverse polarity circuit to open on trouble, if no alarm exists.

The wiring of this module must follow the requirements as specified under "Power-limited Wiring Requirements" on page 19.

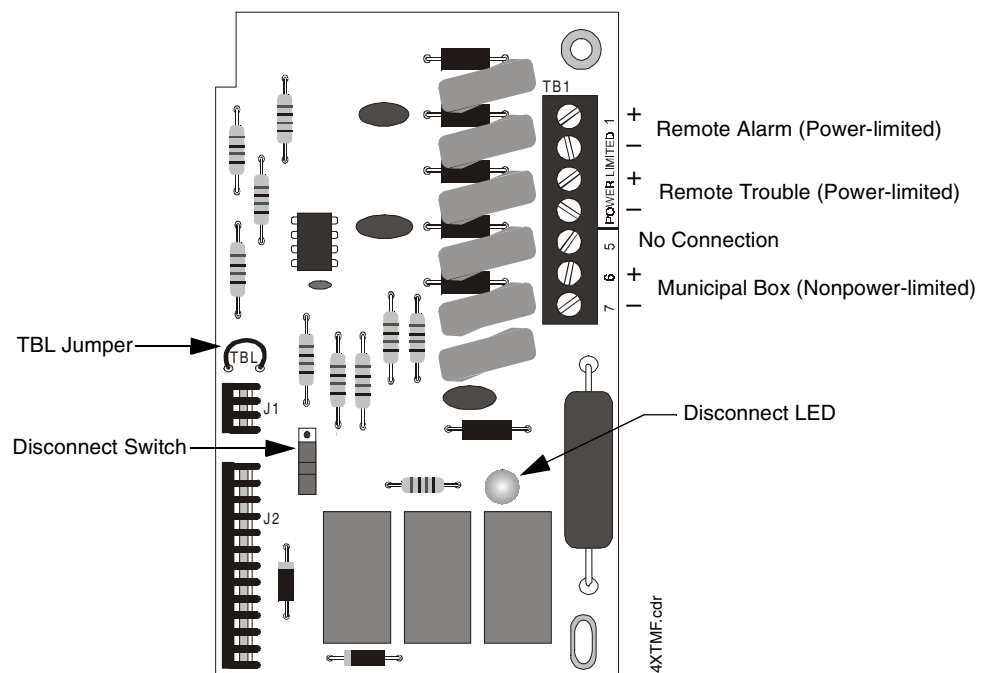

Figure 15 4XTMF Configuration

Zone Relay Module - 4XZMF

Relay #1 through #4 on this module have specific functions based on the configuration of DIP switches #1 and #2 on the control panel. See “Zone Relay Module Configuration” on page 32 for a more detailed explanation of the conditions that will activate each relay under the different DIP switch settings.

For non-latching (silenceable) relay operation, cut the jumper “LATCH”. If this jumper is left intact, the relays will latch upon activation. To disconnect relays entirely, slide the disable switch to the right.

Note: If any dry contacts are to be used as nonpower-limited circuits, write this on the Protected Premises Unit label, located on the door of the control panel.

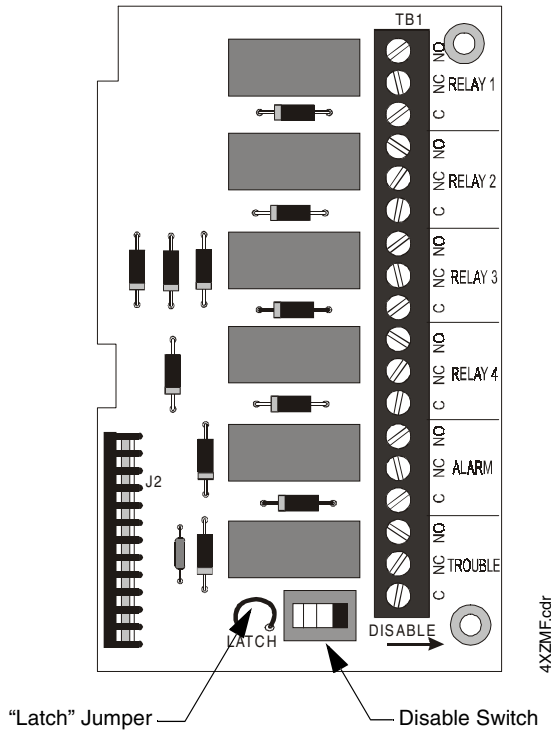

Figure 16 Wiring the Zone Relay Module

The wiring of this module must follow the requirements specified under "Power-limited Wiring Requirements" on page 19.

- If this module is used to drive both nonpower-limited and power-limited circuits, skip one set of dry contacts to maintain the required separation between circuit types.
- If this module is used to drive both nonpower-limited and power-limited relays that are *next to each other*, refer to the figure below which shows the one allowable arrangement.

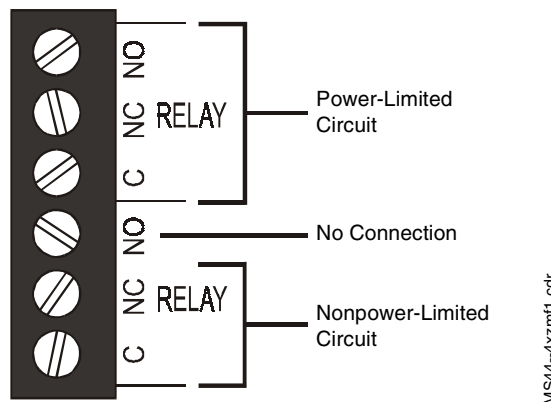

Figure 17 Mixing Power-Limited and Nonpower-Limited Circuits

LED Interface Module - 4XLMF

Connect the terminals on TB1 of the LED Interface Module to the corresponding terminals of the RZA-4XF Remote Annunciator.

Make wiring connections with system power off.

Maximum wire impedance is 50 ohm per wiring connection.

The wiring of this module must follow the requirements as specified under "Power-limited Wiring Requirements" on page 19.

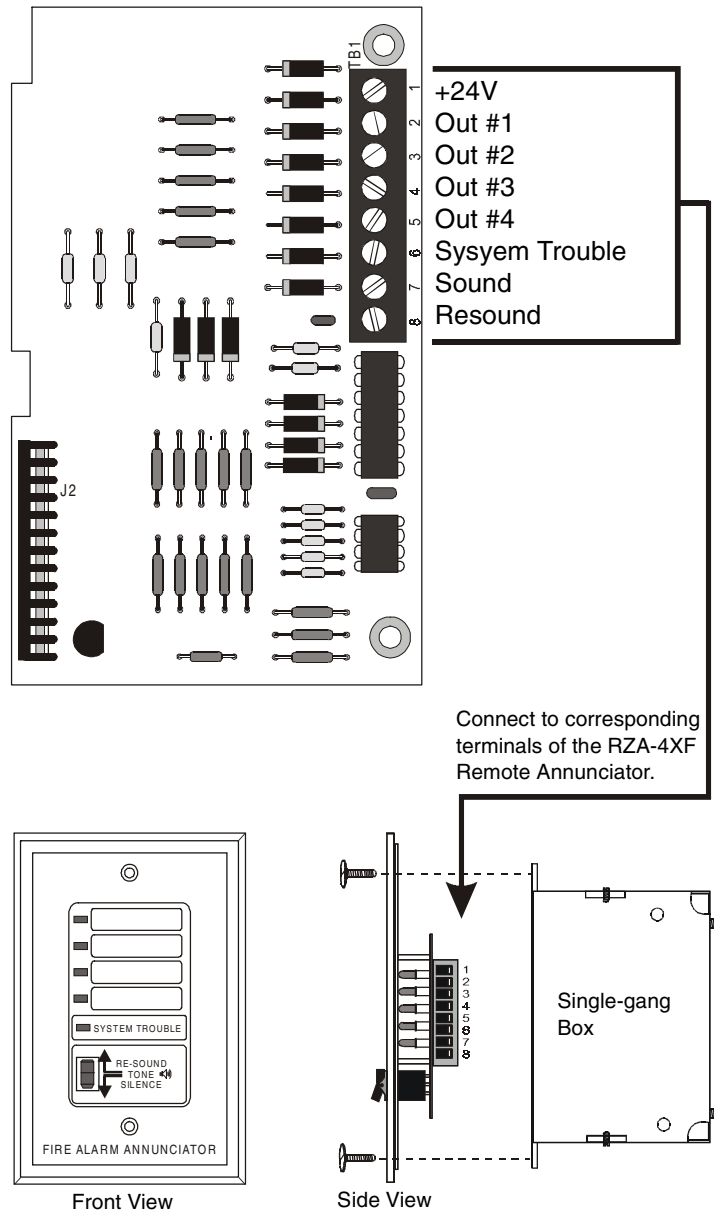

Figure 18 Connection of 4XLMF to RZA-4XF

Setting Mode of Operation

Select operating mode by setting the SW1 DIP switches as described below; basic programming options are shown in this section.

After any changes are made to the configuration of the switches, the panel must be reset.

For Canadian use, refer to "Sprinkler Supervisory Tracking" on page 38.

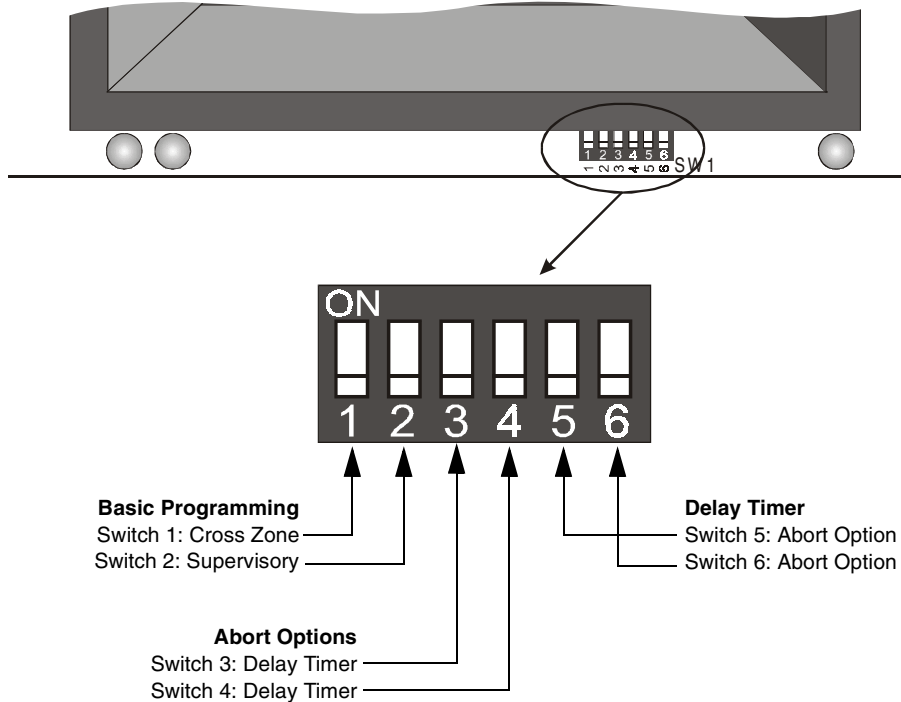

Figure 19 DIP Switch Settings

DIP Switch Functions

Switch #1 - Cross Zone

Select the desired mode of operation and set switch per appropriate column:

OFF		ON	
NAC #1	Activated by an alarm in either IDC # 1 or IDC #2.	NAC #1	<u>Pre-discharge Alarm</u> - Activated by the first alarmed zone in the system. Initiation of an alarm on the other zone will shut this output off
NAC #2	Activated by an alarm in either IDC #1 or IDC #2. Note: The NAC will pulse at 60 ppm while timer is running or frozen by abort and will sound steady upon release (time out).	NAC #2	Activated when alarms occur on both IDC #1 or IDC #2. Note: The NAC will pulse at 60 ppm while timer is running or frozen by abort and will sound steady upon release (time out).
REL #1 REL #2	Will be activated when the timer expires (provided that REL #2 is functioning as a releasing circuit - set via DIP switch #2)		
The Releasing Circuit Delay Timer will start whenever an alarm occurs on <i>either</i> IDC #1 or IDC #2.		The Releasing Circuit Delay Timer will start whenever an alarm occurs on <i>both</i> IDC #1 or IDC #2.	

Switch #2 - Supervisory/Releasing Service

Set the function of Releasing Circuit #2 by setting this switch.

OFF		ON	
REL #2	Will function as a solenoid releasing circuit. Note: This circuit is nonpower-limited.	REL #2	Will function as a supervisory input circuit. <ul style="list-style-type: none"> A short condition on this circuit will light the Supervisory LED and sound the supervisory tone on the control panel piezo. An open condition generates a circuit trouble condition. Note: This circuit will now be power-limited.

Switch #3 and #4 - Timer Delay

Select the desired timer setting and set these switches accordingly.

	No Delay*	10 Second	20 Second	30 Second
Switch #3	OFF	OFF	ON	ON
Switch #4	OFF	ON	OFF	ON
* Abort timer will not operate when timer is set for 'No Delay'.				

Switch # 5 and #6 - Abort Function

Select the desired Abort Functions for delaying the activation of releasing circuits, and set these switches accordingly. If 'Cross Zone' is selected, both IDC #1 and IDC #2 must be activated to start timer.

Switch #5	OFF	OFF	ON	ON
Switch #6	OFF	ON	OFF	ON
	Standard UL-type delay timer	IRI-type delay timer	NYC-type delay timer	Local Jurisdiction delay timer
	Continues to count down upon ABORT, but stops and holds at 10 seconds until release of the ABORT switch. Upon release of the ABORT switch, the timer resumes the countdown at 10 seconds.	Functions the same as the UL-type timer with the exception that the ABORT will function only if pressed and held before 2nd zone goes into alarm.	When an alarm exists, pressing ABORT changes timer value to the Timer Delay plus 90 seconds. The timer will not start while ABORT is held. SYSTEM RESET restores timer to original Timer Delay. Each time ABORT is pressed again adds 90 seconds to Timer Delay.	Once the timer has started, pressing ABORT resets the timer to full Timer Delay. The timer will not start while ABORT is held. Releasing the ABORT switch continues the countdown; pressing ABORT again restores Timer Delay to its full value.
	<div style="border: 1px solid black; padding: 2px; display: inline-block;"> These modes are the only ones that comply with UL Standard 864. </div>			
	Note: Abort timer will not operate when timer is set for 'No Delay'. Manual pull station does not use abort mode.			

Zone Relay Module Configuration

Relay #1, #2, #3 and #4 of the the 4XZMF Zone Relay Module have specific functions based on the configuration of DIP Switches #1 and #2 on the control panel. The table below provides a description of these functions.

	DIP #1 is OFF (Either Zone)	DIP #1 is ON (Cross Zone)\	DIP #2 is ON (Supervisory)	
			Either Zone	Cross Zone
Relay #1	Activate when alarm is detected in Zone #1 or Zone #2	Activates when first alarm is detected in the system	Same	Same
Relay #2		Activates upon second alarm		Same
Relay #3	Activates when Release 1 is activated	Activates when Release 1 is activated	Same	Same
Relay #4	Activates when Release 2 is activated	Activates when Release 2 is activated	Not Used	Not Used
Note: Relay #5 is reserved for General Alarm and Relay #6 is reserved for System Trouble.				

Power-Up Procedure



WARNING: Prior to energizing this panel, notify all personnel and authorities, including any personnel who may be working on, around, or near this unit.



WARNING: Battery contains sulfuric acid which can cause severe burns to the skin and eyes and can destroy fabrics. If contact is made with sulfuric acid, immediately flush the skin or eyes with water for 15 minutes and seek immediate medical attention.



CAUTION: Observe polarity of batteries. Improper connection will cause damage and VOID WARRANTY.

Follow these steps to power-up the FACP:

1. **Conduct Visual Inspection.** A careful visual inspection should be made before applying power to the system. See "Inspection" on page 49.
2. **Notification.** Notify personnel who may be working with the AC power circuits before removing the "Out of Service" tag.
3. **Apply Primary Power.** Switch the circuit breaker to the 'closed' position, providing power to the circuit.
 - The green AC power LED will illuminate.
 - The Trouble LED will illuminate until battery power is applied.
4. **Connect Secondary Power.** Connect battery interconnect wire as shown below.
 - The trouble LED will clear. If the trouble light does not clear, refer to "Troubleshooting Table" on page 50.

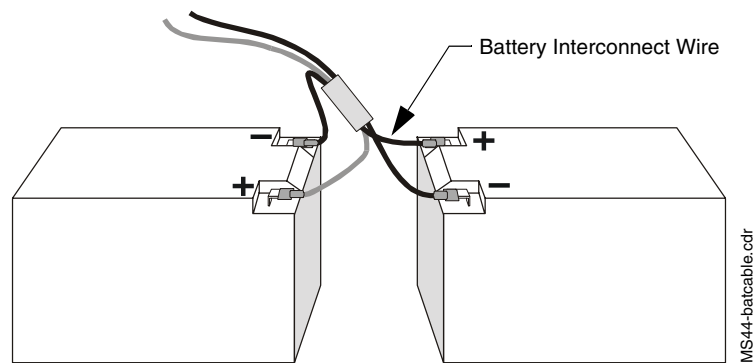

Figure 20 Battery Connections

Notes

3. System Operation



WARNING: When used for CO₂ releasing applications, observe proper precautions as stated in NFPA 12. Do not enter the protected space unless physical lockout and other safety procedures are fully completed. Do not use software disable functions in the panel as lockout.

System Status LEDs

Alarm, Trouble and Supervisory LEDs will flash on and off until the event(s) has been acknowledged (TONE or ALARM SILENCE), at which point the LED will illuminate steadily.

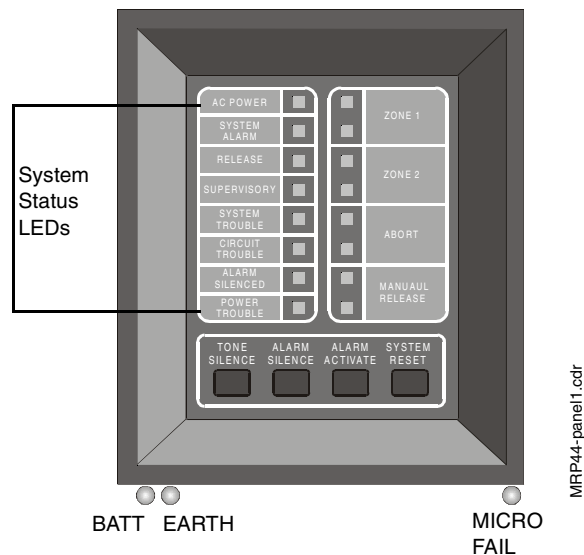

Figure 21 System Status LEDs

AC Power - Green LED that illuminates steadily to indicate presence of AC power.

System Alarm - Red LED that flashes when an alarm occurs.

Release - Red LED that illuminates steadily when release occurs.

Supervisory - Yellow LED that flashes upon activation of a supervisory device (such as tamper switch) on Zone 4.

System Trouble - Yellow LED that flashes for any trouble condition, including those associated with optional boards.

Circuit Trouble - Yellow LED that flashes for trouble conditions on output circuits (notification and releasing).

Alarm Silenced - Yellow LED that illuminates steadily when the ALARM SILENCE switch has been pushed after an alarm.

Power Trouble - Yellow LED that flashes for low or disconnected batteries and earth fault conditions.

The following LEDs are located below the main panel and are visible only when the panel door is open.

Battery Fail (BATT) - Yellow LED that illuminates steadily on motherboard when battery is low or not detected.

Ground Fault (EARTH) - Yellow LED that illuminates steadily on motherboard during a ground fault condition.

Micro Fail - Yellow LED that illuminates on motherboard when watchdog timer detects microprocessor failure.

Control Switches



Figure 22 Control Panel Switches

Tone Silence - Pressing this switch acknowledges alarms, troubles and supervisories. The panel has alarm and trouble resound with LED flash of new conditions. The flashing trouble LED(s) illuminate steadily and the piezo turns off. A second trouble will resound the piezo. Trouble conditions are self-restoring. Alarms latch and require pressing SYSTEM RESET to clear. Unless the unit is set for non-latching supervisory service, supervisories latch and require pressing SYSTEM RESET to clear. The piezo has three tones for different conditions (see "Piezo" on page 37).

Alarm Silence - Pressing this switch acknowledges for alarms and supervisories. This switch will silence the local piezo, change any flashing alarm LEDs to steady, and turn off the notification circuits. The "Alarm Silenced" LED will illuminate. Alarm silence is a latching function and requires pressing SYSTEM RESET to clear.

Alarm Activate - This switch may be used to activate Notification Appliance Circuits (NACs). It also activates the System Alarm Relay. This is a latching function. Pressing ALARM SILENCE silences the NACs and System Alarm Relay, and lights the Alarm Silenced LED. Pressing SYSTEM RESET returns the system to normal.

System Reset - This switch breaks power to all initiating circuits, four-wire smoke detector power and optional boards and will clear any activated output circuits. If any alarm or trouble still exists after reset, they will reactivate the panel. Holding SYSTEM RESET down will perform a LAMP TEST function and will activate the piezo sounder.

Zone Status LEDs

The alarm and/or trouble LED(s) will flash until the event(s) has been acknowledged (TONE or ALARM SILENCE), at which point the LED(s) will illuminate steadily.

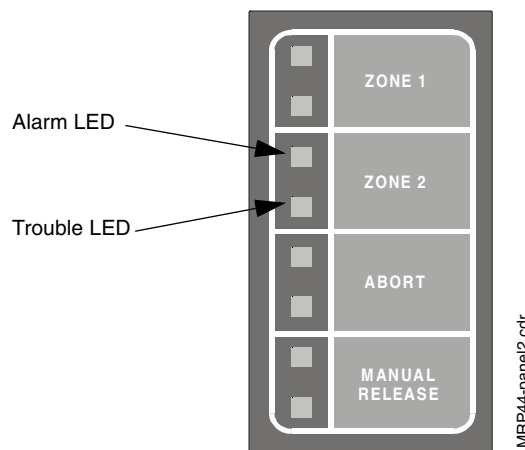

Figure 23 Zone Status LEDs

Piezo

The piezo (local buzzer) generates different tone patterns for different event conditions:

- **Alarm** - Generates a steady tone, no pulse.
- **Trouble** - Pulses one second on, one second off. Repeats 30 pulses per minute.
- **Supervisory** - Pulses one-half second on, one-half second off. Repeats 60 pulses per minute.

Supervisory Service

Releasing circuit #2 can be used as an input for monitoring supervisory devices (such as valve tamper switches) by setting SW1 DIP switch 2 to "ON" (see "Setting Mode of Operation" on page 30). After the panel is programmed for supervisory service, a short circuit on this input (activation of a N.O. contact) will cause the supervisory LED to flash. The piezo sounder will generate a unique sound. Pressing TONE SILENCE will silence the piezo and cause the supervisory LED to illuminate steadily. Supervisory signals latch and require SYSTEM RESET to clear. An open circuit will be reported as a circuit trouble.

Note: The Initiating Device Circuit for sprinkler supervisory zone can be programmed for tracking operation; latching operation is the default setting. Canadian regulations require latching operation; for programming instructions, see "Sprinkler Supervisory Tracking" on page 38.

Zone Disable

If a zone has been disabled, an alarm that occurs on that zone will flash the red zone LED, but not the piezo or any output circuit. *If both power sources are removed from the system, all zones will be re-enabled upon restoration of power. Disable status will be lost.*

The Zone Disable routine makes use of the four panel switches as follows: I

1. Press and hold in the TONE SILENCE switch.
2. With the TONE SILENCE switch held in, press (in sequence) the ALARM SILENCE switch, the ALARM ACTIVATE switch, and then the SYSTEM RESET switch.
3. The Zone 1 Alarm LED will flash.
4. To disable Zone 1, press the SYSTEM RESET switch. The Zone 1 yellow LED will light to show that the zone is disabled.

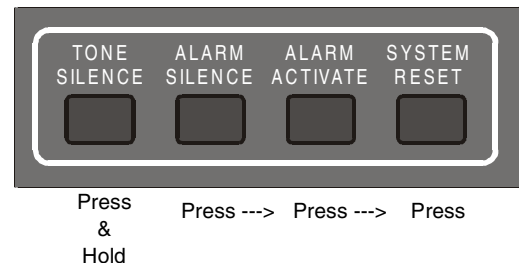

Note: The SYSTEM RESET switch toggles disable status for the selected zone.

5. To select the next zone, press the ALARM SILENCE switch.
6. To select the previous zone, press the ALARM ACTIVATE switch.
7. When disable selections are complete, release the TONE SILENCE switch.

If any zone has been disabled, the trouble relay will activate and System Trouble LED will flash.

Last Event Recall

Last Event Recall allows the user to display the previous panel status. The Last Event Recall makes use of the four panel switches as follows:

1. Press and hold in the TONE SILENCE switch.
2. With the TONE SILENCE switch held in, press (in sequence) the SYSTEM RESET switch, the ALARM ACTIVATE switch, and then the ALARM SILENCE switch.
3. LEDs will light to indicate the last event recorded in the panel's buffer.
4. Release the TONE SILENCE switch to return to normal operation.

To clear the Last Event buffer, press SYSTEM RESET twice.

Non-Silenceable Service

Notification Appliance Circuit #1 can be programmed as non-silenceable by following these steps:

1. Press and hold in the TONE SILENCE switch.
2. With the TONE SILENCE switch held in, press in sequence the ALARM SILENCE switch, then the ALARM ACTIVATE switch, and finally the ALARM SILENCE switch again.
3. Release the TONE SILENCE switch.

Note: If both primary and secondary power sources are removed from the system, these settings will be lost. When power is restored, Notification Appliance Circuit #1 will default to silenceable operation.

Sprinkler Supervisory Tracking

The Initiating Device Circuit for sprinkler supervisory zone can be programmed for tracking operation; latching operation is the default setting. Canadian regulations require latching operation.

1. Press and hold in the TONE SILENCE switch.
2. With the TONE SILENCE switch held in, press in sequence the ALARM SILENCE switch, then the ALARM ACTIVATE switch, and finally the ALARM ACTIVATE switch again.
3. Release the TONE SILENCE switch.

Note: If both primary and secondary power sources are removed from the system, this setting will be lost. When power is restored, supervisory will default to latching operation.

System Events

Standby Condition

Green LED (AC power on) will be illuminated. All other LEDs (trouble and alarm) are off.

System Trouble Condition

Interruption of any of the electrically supervised circuits will illuminate the System Trouble LED. The Trouble Relay Contacts will transfer. The piezo (local buzzer) will sound one second on, one second off, and repeating until silenced. Silence the piezo by pressing the TONE SILENCE switch. The panel will remain in the trouble state until the trouble condition has been cleared and the panel reset.

Single Zone in Alarm (Cross Zone) Condition

Upon actuation of a single-zone initiating device, a red alarm LED will illuminate to indicate whether Zone 1 or Zone 2 is in alarm.

In addition to the LED, a single-zone alarm will activate the Alarm Relay; the piezo and remote NAC #1 will start sounding. In alarm condition, the piezo will generate a steady tone. The piezo can be silenced by pressing the trouble silence switch. If the fire is extinguished before a second zone alarm is activated, return the system to normal standby condition by pressing the reset switch inside the panel and holding it for three (3) seconds.

Both Zones in Alarm (Cross Zone) Condition

When the first alarm occurs, the panel will function as described above.

Upon the occurrence of a second alarm, NAC #1 will de-energize. The second alarm LED will illuminate, and NAC #2 will energize. At the same time, the predischarge timer will be activated. At the end of the timer cycle the solenoid valve(s) will be energized to release the suppressant agent.

Manual Discharge Station Alarm Condition

Manual discharge does not use the predischarge timer. If a manual station is used to initiate the alarm condition, the following will take place:

- IDC #2 and the piezo will be activated. (In alarm condition, the piezo will generate a steady tone.)
- Alarm Relay will be activated.
- The solenoid valve(s) will activate.

Brownout Condition

The total power being provided to the system's power supply should not exceed the current draw during fully loaded panel operation. Brownout circuitry annunciates degradation of the incoming AC voltage supply. A brownout condition is annunciated when the AC power decreases. When the brownout threshold is reached, the system reacts as if AC power is totally lost:

- Battery backup begins supplying power to operate the control panel
- General Trouble Relay contact transfers
- Green AC Power LED turns off
- Yellow System Trouble LED illuminates
- The piezo will sound one second on, one second off, and repeat until the Trouble is cleared.

When the AC voltage returns or increases above the brownout threshold, the green AC Power LED will illuminate. The power supply circuitry will return to primary power functions and begin to recharge the backup battery supply.

Notes

Appendix A: Secondary Power Calculations

Standby Battery Requirements

The Standby Battery Current obtained in the table below represents the amount of current that must be supplied by the secondary power source (batteries) to sustain control panel operation for one hour.

Note: The control panel will support the installation of one or two optional modules, including two of the same type of module. Only one 4XLMF can be included in this count.

Device Type	# of Devices		Current (amps)	=	Total Current (amps)
Main Circuit Board	1	X	0.088	=	0.088
4XZMF ZoneRelay Module	[]	X	0.008	=	
4XTMF Transmitter Module	[]	X	0.011	=	
• Reverse Polarity Alarm output	[]	X	0.005	=	
• Reverse Polarity Trouble output	[]	X	0.005	=	
RZA-4XF/4XLMF Remote Annunciator	[] (1 max)	X	0.019	=	
4XMMF Meter Module	[]	X	0.001	=	
2-wire Detector Heads	[]	X	[] ¹	=	
4-wire Detector Heads	[]	X	[] ¹	=	
End-of-line Relays ²	[]	X	[]	=	
Current Draw from TB2 (nonalarm) ³	[]	X	[]	=	
Standby Battery Current =					amps

1. Refer to the Device Compatibility Document for smoke detector standby current.
2. Must use compatible listed Power Supervision Relay.
3. The total standby current must include both the resettable (TB1 - +24VR terminals) and nonresettable (TB2 - +24VNR terminals) power. Caution must be taken to ensure that current drawn from these outputs during alarm does not exceed maximum ratings specified.

Table 1 Standby Battery Current

Calculating the Battery Capacity

Use this table to determine the battery capacity required by the system.

Standby Battery Current (from Table 1) [] amps	X	Required Standby Time in Hours (typically 24 ¹ , 60 ² , or 90 ³ hours) [] hrs	=		Standby Amp Hours
		Enter: 0.25 for 5 minutes in alarm, or 0.50 for 10 minutes in alarm			Alarm ⁴ Amp Hours
		Total Standby and Alarm Load	+		
		Multiply by derating factor	X	1.2	
		Battery size required in AH	=		

1. NFPA 72 Central Station and Local and Proprietary Fire Alarm Systems require 24 hours of standby time.
2. NFPA 72 Auxiliary and Remote Station Fire Alarm Systems require 60 hours of standby time.
3. Factory Mutual Systems require 90 hours of standby for releasing service.
4. Alarm AH assumes a maximum system draw of 3 amps in alarm for 5 minutes (0.25 AH) or for 10 minutes (0.5AH).

Table 2 Amp Hour Calculations

The battery charger in this panel will charge a maximum of 18 AH of batteries within 48 hours (7 AH minimum). Batteries larger than 12 AH will require a UL-listed battery cabinet (e.g. Fire•Lite BB-17F).

Select a battery with an equal or greater AH rating than the value obtained in the table above.

Note: Batteries must be lead-acid type.

Appendix B: NFPA Standard-Specific Requirements

Minimum System Requirements

The control panel has been designed for use in commercial, industrial, and institutional applications and meets the requirements for service under the National Fire Protection Association (NFPA) Standards outlined in this appendix. The minimum system components required for compliance with the appropriate NFPA standard are listed below.

- **Fire Alarm Control Panel.** Contains the main control board, cabinet (backbox and door), main supply transformer and power supply.
- **Batteries.** Refer to "Appendix A: Secondary Power Calculations" on page 41
- **Initiating Devices.** Connected to one of the control panel's Initiating Device Circuits.
- **Notification Appliances.** Connected to one of the control panel's Notification Appliance Circuits.
- **Releasing Devices.** Connected to one of the control panel's Releasing Circuits.

Additional Requirements

The following additional equipment is needed for compliance with the NFPA standards listed below. The relay contacts of this control panel may be used to trip any dialer that is UL listed for Central Station/Remote Station services. The illustrations in this appendix provide examples of possible system configurations.

Note: Applications which require the the NOTI-FIRE 911AC or the Potter EFT-C are not FM approved.

NFPA 72 - Signaling Systems for Central Station Service (Protected Premises Unit)

- **NOTI-FIRE 911AC Digital Alarm Communicator/Transmitter (DACT)** connected to a compatible listed Central Station DACR or Protected Premises Receiving Unit. See "Digital Alarm Communicator/Transmitter - Noti-Fire 911AC" on page 44 for installation instructions for this unit.
- **411UDAC Universal Digital Alarm Communicator** connected to a compatible listed Central Station DACR or Protected Premises Receiving Unit. See "Universal Digital Alarm Communicator - 411UDAC" on page 45 for installation instructions for this unit.

NFPA 72 - Auxiliary Fire Alarm System

- **4XTMF Transmitter Module** for connection to a compatible listed Local Energy Municipal Box. See "Local Energy Municipal Box" on page 46 for installation instructions for this unit.

NFPA 72 - Remote Station Fire Alarm System

- **Fire•Lite RS82-9 Remote Station Receiver** connected to a 4XTMF Transmitter Module. See "Remote Station Receiver - RS82-9" on page 47 for installation instructions for this unit.
- **NOTI-FIRE 911AC DACT** connected to a compatible listed Central Station DACR. See "Digital Alarm Communicator/Transmitter - Noti-Fire 911AC" on page 44 for installation instructions for this unit
- **411UDAC Universal Digital Alarm Communicator** connected to a compatible listed Central Station DACR. See "Universal Digital Alarm Communicator - 411UDAC" on page 45 for installation instructions for this unit.

NFPA 72 - Proprietary Fire Alarm System

- **Potter EFT-C McCulloh Transmitter.** See "Potter EFT-C McCulloh Transmitter" on page 48 for installation instructions for this unit.

Digital Alarm Communicator/Transmitter - Noti-Fire 911AC

Note: This application is not FM approved

Using the Noti-Fire 911AC DACT for connection to a Central Station Receiver or Protected Premises Receiving Unit.

- AC Wiring for DACT/FACP must be connected to the same circuit.
- If the unit is not mounted in the control panel's backbox all connections must be in conduit, less than 20 ft. (609.6 cm) in length in the same room.
- For additional information refer to the Noti-Fire 911AC Instruction manual.

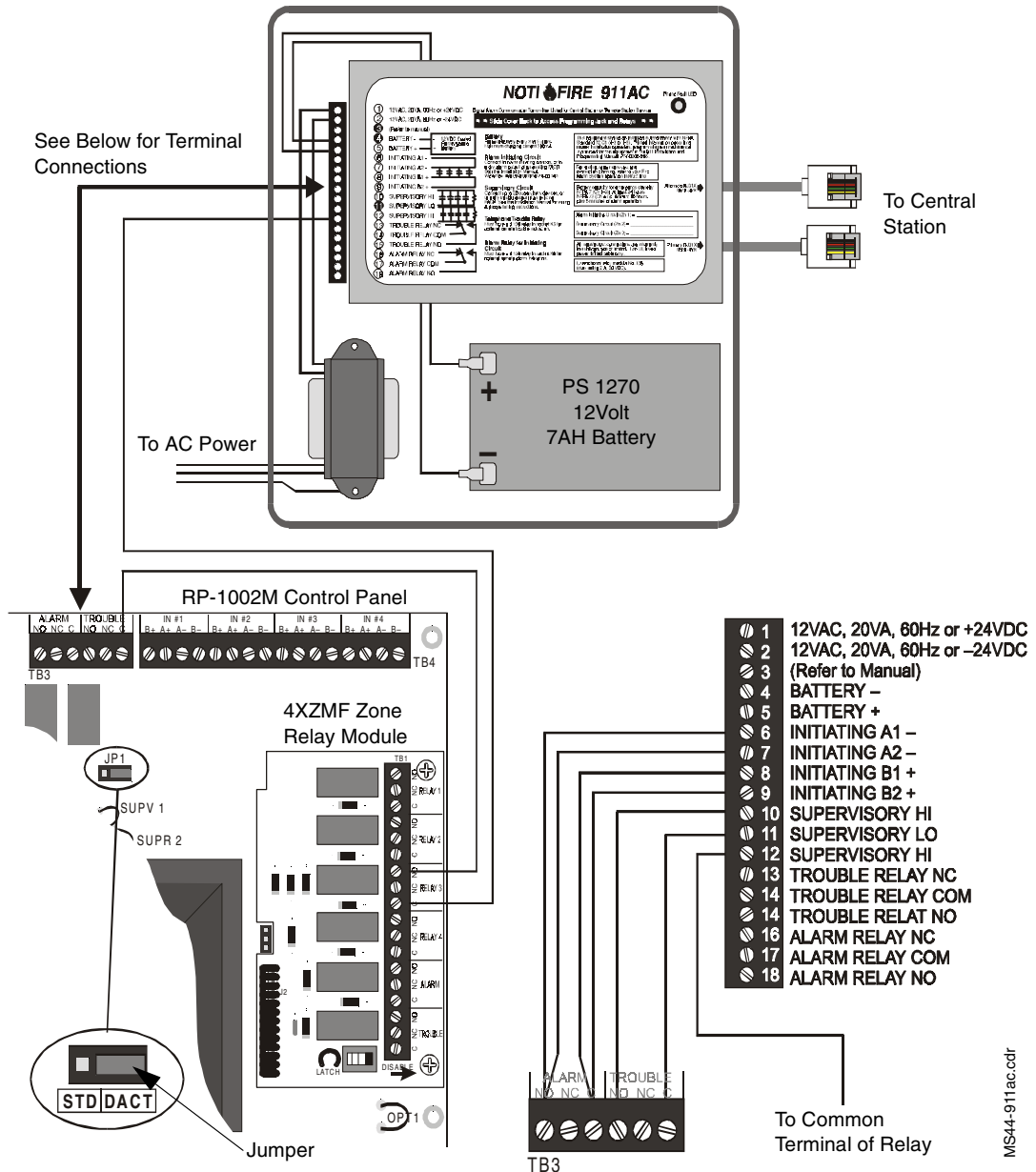

Place jumper over pins as shown when employing a DACT. This directs the control panel to transmit all trouble conditions except AC LOSS.

Figure 24 DACT Connections

MS44-911ac.cdr

Universal Digital Alarm Communicator - 411UDAC

The following figure illustrates an example of Central Station/Remote Station Receiver or Protected Premises Receiving Unit reporting using a 411UDAC. The relay contacts of the RP-1002M may be used to trip any dialer listed for Central Station/Remote Station services. For additional information refer to the Instruction Manual for the 411UDAC.

- All connections between the control panel and the 411UDAC must be in conduit, less than 20 feet (6.1 meters) in length in the same room.
- The RP-1002M is non suitable for transmission of a supervisory signal to the DACT.
- Any zone of the 411UDAC can be wired to function as alarm or trouble; the unit must be programmed accordingly. In this example, Zone 1 is wired to the control panel’s alarm relay, Zone 2 is wired to the control panel’s trouble relay, and Zone 3 is wired to the optional module’s supervisory relay.
- AC power is supplied directly to the 411UDAC, not through the control panel. AC wiring for both the 411UDAC and the control panel must be connected to the same AC branch circuit.
- End-of-Line Resistors must terminate all circuits. In this example, Zone 4 is unused and is terminated at the board.
- When employing a DACT, place the JP1 jumper, on the control panel, as shown below. This directs the panel to transmit all trouble conditions except AC LOSS. The DACT must be configured to transmit AC power loss to the central station.

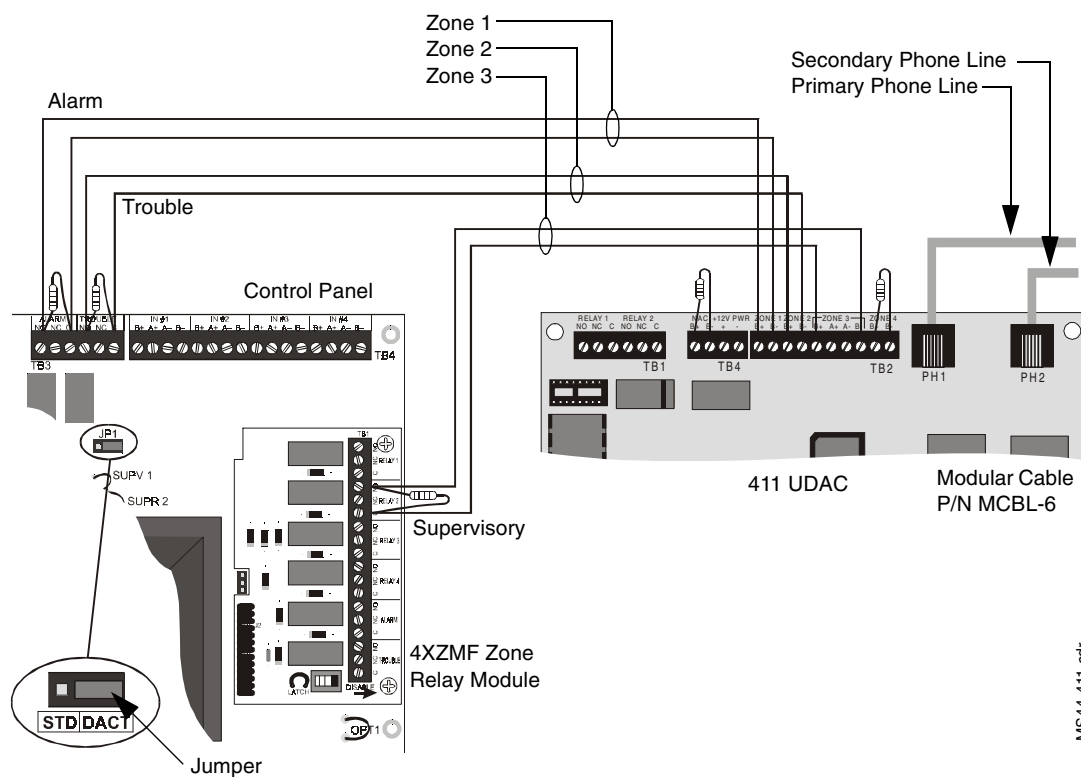

Figure 25 411UDAC Connections

MS44-411.odt

Local Energy Municipal Box

Using the 4XTMF Transmitter Module for connection to a Local Energy Municipal Box.

- The Municipal Box circuit supervises for ground faults and opens (i.e. missing wire) but not for direct short between two wires. It is not a power-limited circuit.
- This application is not suitable for separate transmission of sprinkler supervisory or trouble conditions.
- Maximum loop resistance allowed for wiring from control panel to Municipal Box is 3 ohms.

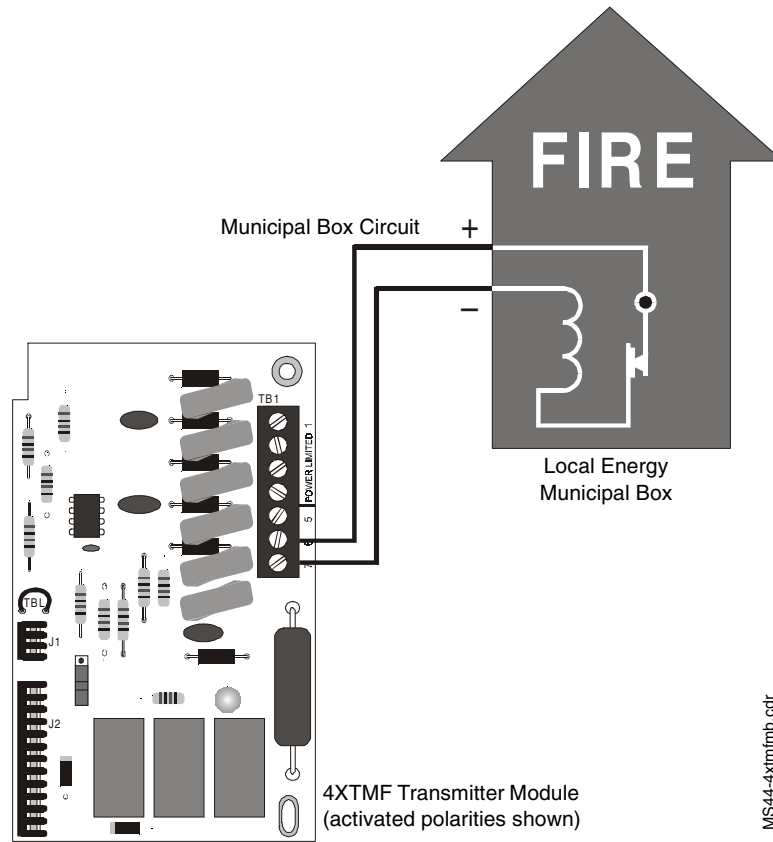

Figure 26 Municipal Box Connection

Remote Station Receiver - RS82-9

Using the 4XTMF Transmitter Module for connection to a Fire•Lite RS82-9 Remote Station Receiver.

- Intended for connection to a polarity reversal circuit of a remote station receiving unit having compatible ratings.
- All connections are power-limited and supervised with the exception of the reverse polarity loop.
- Supervision of the loop is the responsibility of the receiver.

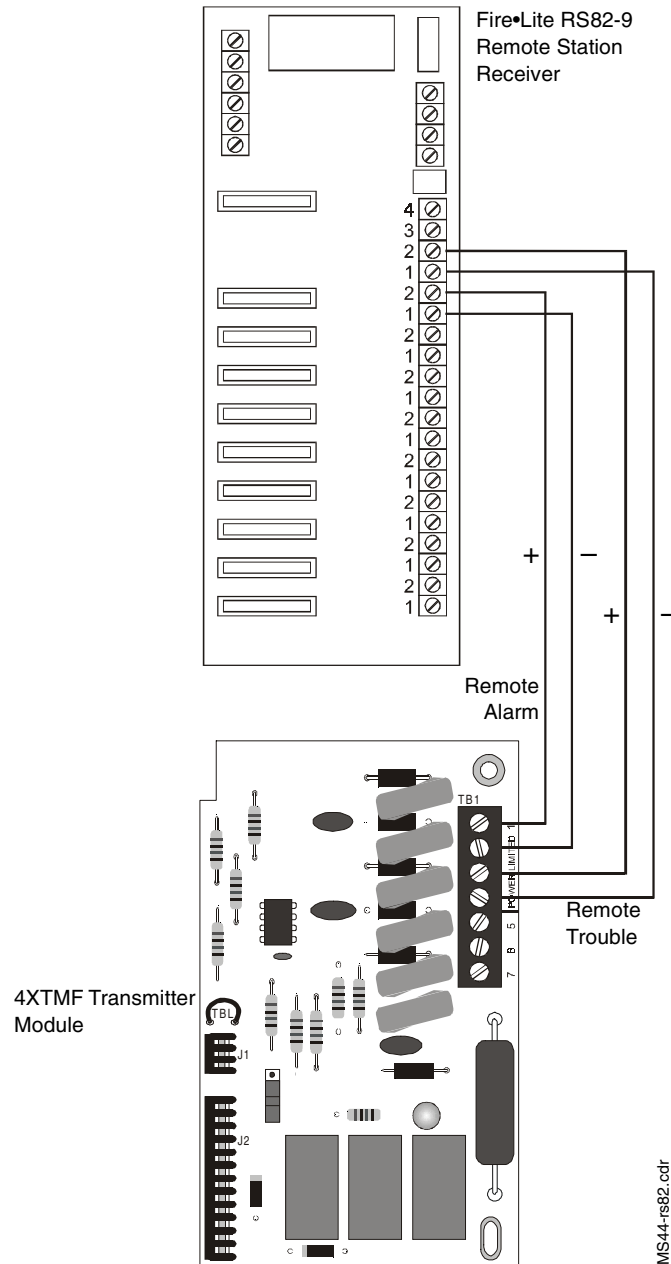

Figure 27 RS82-9 Connections

MS44-rs82.cdr

Potter EFT-C McCulloh Transmitter

Note: This application is not FM approved.

- Connections between control panel and the transmitter are supervised by the transmitter.
- Use transformer model ULT STK. NO. 1000391 (listed, Class 2, 12 V, 10 VA.). See Potter Electric Signal Company Bulletin # 748.
- Form-C Trouble relay which will automatically activate on any trouble condition.
- Form-C Alarm relay programmed to activate on General Alarm.

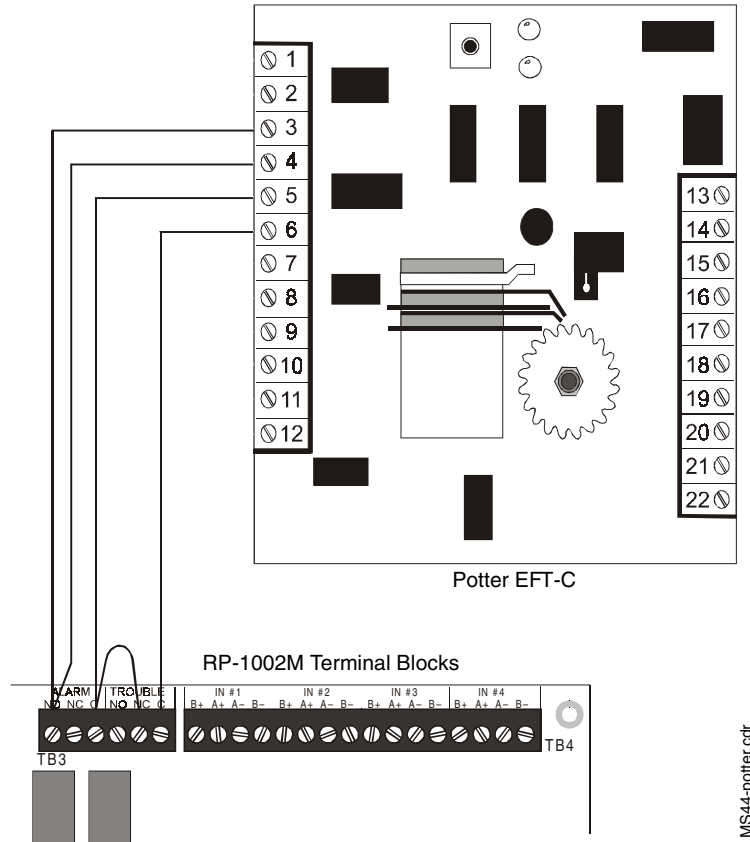

MS44-potter.cdr

Figure 28 Potter EFT-C Connections

Appendix C: Testing & Maintenance

Testing

Inspection

Perform the following prior to applying power to the system.

- Check the actual wiring hookup with the wiring diagrams.
- Insure that no pieces of wire have fallen into the circuitry.
- Check for missing or damaged parts.

Alarm Test

An initial alarm test should be conducted following installation to determine that all parts of the system are functioning properly. The panels should remain powered for 24 to 36 hours prior to connecting the releasing solenoids. This precaution will avoid false discharges of gas in case of faulty or improperly placed detectors.

To perform an alarm test on the panel follow this procedure

1. Disconnect AC power and battery power.
2. Disconnect the installed solenoid valve circuit leads and connect spare solenoid valves, or connect an end-of-line device to serve as a dummy load.
3. Reconnect AC power and battery power.
4. Initiate a first zone alarm condition by blowing smoke into one of the Zone 1 smoke detectors. This should cause the first zone alarm condition.
 - The alarm relay will energize.
 - The red zone alarm LED will be illuminated.
 - The remote Indicating Circuit #1 audible alarm and the local piezo will start sounding.

Maintenance

A regular schedule of inspection, testing, and maintenance is vital to insure proper and reliable operation of the control panel. The procedures should be performed as required by the local authority having jurisdiction. Refer to NFPA for further details.

Troubleshooting

A troubleshooting table is included on the following page which provides for symptoms, problems and their solutions.

Table 3 Troubleshooting Table

Symptom		Problem		Solution	
AC Power LED ON	System trouble LED ON	Circuit trouble LED ON	Notification appliance circuit trouble	1. Check TB2 for proper connections. 2. Remove all field wiring and install dummy ELR at output circuit. Check for supervisory voltage across it, (Normal -2.3 V), if problem persists, replace circuit board. 3. Removed dummy ELR, reconnect field wiring and measure voltage across output; (trouble-5V, short 0V). 4. Check for ELR at last device. 5. Check field wiring.	
		Any of the right column yellow LEDs flashing	Initiating zone open circuit trouble	1. Check TB4 for proper connections. 2. Remove field wiring for zone in trouble and install dummy ELR (4.7K). If problem persists, replace circuit board. 3. Check for ELR at last device. 4. Check field wiring.	
		Any of the right column yellow LEDs steady ON	Zone disable	1. Check installation manual.	
		Power trouble LED ON	Battery trouble Batt yellow LED ON	Missing or Disconnected	1. Check battery connections.
				Low or damaged battery	1. Remove batteries, check voltage across charger output (17 to 19V), otherwise replace circuit board. 2. Reconnect batteries, measure battery voltage at battery terminals. If voltage is less than 85% of rated voltage, allow them to charge for 48 hours. 3. If problem persists, replace batteries.
		Ground fault trouble Earth yellow LED ON	1. Remove field wiring from main panel and optional module(s) (if installed). Install dummy ELR (4.7K). 2. Remove both battery leads. 3. If trouble clears, connect one circuit at the time to pin point the problem. 4. If trouble doesn't clear, replace circuit board.		
	Yellow LED on 4XTMF ON	4XTMF	1. Move Municipal Box disconnect switch SW1 up.		
		OPT1, OPT2 jumper cut	1. Install optional module(s) or replace jumper if module(s) is not used.		
		Municipal Box open circuit	1. Install dummy load if Municipal Box option isn't used. 2. Check Municipal Box wiring.		
	Any of the right column red LEDs ON	Short on initiating circuit wiring	1. Remove field wiring and install ELR. If trouble clears, look for faulty or incorrectly wired devices.		
	Disconnecting Municipal Box switch ON 4XTMF does not create a trouble	Jumper for optional modules isn't cut	1. Cut associated jumper OPT1 or OPT2.		
	4XZMF: associated LED doesn't activate for alarm, trouble or supervisory conditions	Optional module trouble	1. Make sure module is properly installed. 2. Move disable switch SW1 on 4XZMF to the left.		
	RZA-4XF piezo doesn't sound for alarm, trouble or supervisory conditions	4XLMF	1. Make sure that 4XLMF module is installed on J8. 2. Check field wiring.		
	Micro Fail yellow LED ON	Microprocessor damaged	1. Replace circuit board.		
	All RZA-4XF LEDs stay ON	Power wasn't removed prior to installation	1. Press system reset.		
AC Power LED OFF	System trouble LED ON	Loss of main power	1. Check incoming power (TB5).		
		Damaged circuit breaker	1. Replace circuit board.		
	Micro Fail yellow LED ON	Microprocessor damaged	1. Replace circuit board.		

Index

Numerics

110/120 VAC 13
 411UDAC 43, 45
 4XLMF LED Interface Module 11, 25
 4XMMF Meter Module 12, 17
 4XTMF Transmitter Module 10, 25, 43, 46, 47
 4XZMF Zone Relay Module 11, 25, 32
 911AC DACT 43, 44

A

Abort Function 31
 Abort Switch Circuit 20
 Abort timer 31
 AC branch circuit 45
 AC power 35, 45, 49
 accidental discharge 23
 acknowledge 36
 activation 31
 additional equipment 43
 alarm 35, 45
 Alarm Relay 39
 alarm relay 24, 49
 allowable resistance 21
 ammeter 12
 annunciator wiring 11
 audible alarm 49
 authority having jurisdiction 49

B

backbox 15
 backbox rail 15, 16
 Batteries 18, 43
 battery
 cable 19
 capacity 42
 charger 42
 interconnect wire 18, 19
 power 49
 BB-17F 13, 42
 black wire 19
 Brownout circuitry 39
 buffer 38

C

Canadian 30, 37, 38
 Central Station 43, 44, 45
 charging current 17
 circuit
 Remote Alarm 27
 Remote Trouble 27
 reverse polarity 10
 circuit board 15
 circuit breaker 18

CO2 releasing applications 35
 conductors 15
 conduit 15, 45
 configuration, Zone Relay Module 32
 Cross Zone 30, 39
 current 13, 23
 current draw 39

D

DC power connections 24
 de-energize 39
 delay timers 31
 detector, four-wire smoke 36
 detectors, type of 20
 devices 23
 devices, supplementary 24
 dialer 43, 45
 DIP switch 22, 28, 30, 37
 DIP Switch #1 30, 32
 DIP Switch #2 31, 32
 DIP Switch #3 & #4 31
 DIP Switch #5 & #6 31
 DIP switch functions 10
 direct short 46
 disable switch 28
 disabled zone 37
 discharge, accidental 23
 Disconnect LED 27
 Disconnect Switch 27
 dry contacts 28
 dummy load 22, 23
 dummy load resistor 20
 duplicate modules 25

E

earth fault 35
 ELR 21, 22
 End-of-Line Resistor 13, 45
 energize 39
 event 35
 exterior dimensions 16
 external battery cabinet 13
 external devices 13

F

Fire Alarm Control Panel 43
 first alarm 39
 first zone 49
 FM approved 43, 44, 48
 Form-C contacts 11, 13
 Form-C relays 48
 four-wire smoke detector 13, 36

Index

G

General Alarm 32, 48
ground fault 35, 46

I

Indicating Circuit #1 49
initial alarm test 49
initiating circuits 36
initiating device 39, 43
Initiating Device Circuit 38
inspection 49
interconnect wire, battery 33
Interface Module 11
interruption of circuits 38
IRI-type delay timer 31

J

J1 connector 15, 16
J2 Connector 17
J3 Connector 17
J9 Connector 19
JP1 jumper 45
jumper 25, 26
 LATCH 28

K

keyhole 15
knockouts 15, 19

L

label
 Protected Premises Unit 28
 terminal identification 25, 26
LAMP TEST function 36
latch 36, 37
LATCH jumper 28
latching operation 37, 38
LED
 Disconnect 27
 System Trouble 27
LED Interface Module 11, 25
LEDs
 Alarm, Trouble and Supervisory 35
Local Energy Municipal Box 10
Local Jurisdiction delay timer 31
loop resistance 46
lower position 25, 26

M

main breaker panel 18
maintenance 49
Manual Pull Stations 20
Manual Release Circuit 20
manual station 39
maximum allowable resistance 23

Maximum Battery Capacity 13
Maximum Charging Circuit 13
maximum resistance 21
Meter Module 12, 17
microprocessor 35
minimum clearance 15
minimum voltage 23
module connectors 25
motherboard 35
mounting hole locations 16
mounting holes 15
Municipal Box 27, 46

N

NACs 22
National Electrical Code, Article 760 18
National Fire Protection Association 43
negative 19
NFPA 49
NFPA standards 43
non-latching 28, 36
nonpower-limited 19, 23, 28
nonresettable power 21, 24
non-silenceable service 22
Notification Appliance Circuit 36
Notification Appliances 43
NYC-type delay timer 31

O

opens 46
operating mode 30
operating voltage 21
optional boards 36
optional modules 10
Out of Service 33
output circuits 36
overcurrent protection 18

P

paper labels 11
physical lockout 35
piezo 36, 37, 38, 39, 49
piezo tones 36
polarity 19, 20, 33
polarity reversal circuit 47
polarized devices 20, 22
positive 19
Potter EFT-C McCulloh Transmitter 43
Potter Electric Signal Company 48
power connection 18
Power Supervision Relay 21
power-limited 19, 22, 23, 28, 47
power-limited power supply 24
predischage timer 39
previous panel status 38
primary power 18, 33

programmed 45
 Protected Premises Receiving Unit 43, 44, 45
 protected space 35

R

rail 26
 rail, backbox 15, 16
 red wire 19
 regulated power 24
 relay contacts 45
 Relay, System Alarm 36
 release 35
 releasing 23
 Releasing Circuit 22, 23
 Releasing Circuit #2 31
 Releasing Devices 43
 Remote Alarm circuit 27
 Remote Annunciator 11
 Remote Station 43, 45
 Remote Station Service 10
 Remote Trouble circuit 27
 reset switch 39
 resettable power 21, 24
 resistance, allowable 21
 resistor 45
 resound 36
 reverse polarity 27
 reverse polarity circuit 10
 reverse polarity loop 47
 RS82-9 Remote Station Receiver 43, 47
 RZA-4XF Remote Annunciator 11

S

second alarm 39
 Secondary Power 33
 secondary power source 41
 self-restoring 36
 separate transmission 46
 short circuit 37
 silence switch 11
 Slide-in paper labels 11
 solenoid valve 39, 49
 sprinkler 37, 38
 sprinkler supervisory 46
 Standard UL-type delay timer 31
 Standby Battery Current 41
 stand-off 16, 25, 26
 Style B (Class B) 20
 Style D (Class A) 20
 Style Y (Class B) 22, 23
 Style Z (Class A) 22
 sulfuric acid 33
 supervised 22
 Supervisory Circuit 23
 supervisory device 35, 37
 supervisory signal 45

Supervisory/Releasing Service 31
 supplementary devices 24
 suppressant agent 39
 switch, disable 28
 System Alarm Relay 36
 System Trouble 32
 System Trouble LED 27

T

tag, "Out of Service" 33
 terminal identification label 25, 26
 testing 49
 Timer Delay 31
 timer, pre-discharge 39
 timer, watchdog 35
 tone patterns 37
 tones, piezo 36
 tracking operation 37, 38
 transformer 48
 transformer wires 15, 16
 transmitter 48
 Transmitter Module 10, 25, 46, 47
 trim ring 16
 trouble 45
 condition 35, 38, 46, 48
 relay 24
 trouble sounder 11
 troubleshooting 49

U

UL listed 43
 UL Standard 864 31
 unused circuits 22, 23
 upper position 25

V

visual inspection 33
 voltage 17
 voltage drop 13
 voltmeter 12

W

watchdog timer 35
 Waterflow 20
 wire, primary power 18
 wires, transformer 15

Z

zone 45
 Zone Relay Module 11, 25

Limited Warranty

The manufacturer warrants its products to be free from defects in materials and workmanship for eighteen (18) months from the date of manufacture, under normal use and service. Products are date-stamped at time of manufacture. The sole and exclusive obligation of the manufacturer is to repair or replace, at its option, free of charge for parts and labor, any part which is defective in materials or workmanship under normal use and service. For products not under the manufacturer's date-stamp control, the warranty is eighteen (18) months from date of original purchase by the manufacturer's distributor unless the installation instructions or catalog sets forth a shorter period, in which case the shorter period shall apply. This warranty is void if the product is altered, repaired, or serviced by anyone other than the manufacturer or its authorized distributors, or if there is a failure to maintain the products and systems in which they operate in a proper and workable manner. In case of defect, secure a Return Material Authorization form from our customer service department. Return product, transportation prepaid, to the manufacturer.

This writing constitutes the only warranty made by this manufacturer with respect to its products. The manufacturer does not represent that its products will prevent any loss by fire or otherwise, or that its products will in all cases provide the protection for which they are installed or intended. Buyer acknowledges that the manufacturer is not an insurer and assumes no risk for loss or damages or the cost of any inconvenience, transportation, damage, misuse, abuse, accident, or similar incident.

THE MANUFACTURER GIVES NO WARRANTY, EXPRESSED OR IMPLIED, OF MERCHANTABILITY, FITNESS FOR ANY PARTICULAR PURPOSE, OR OTHERWISE WHICH EXTEND BEYOND THE DESCRIPTION ON THE FACE HEREOF. UNDER NO CIRCUMSTANCES SHALL THE MANUFACTURER BE LIABLE FOR ANY LOSS OF OR DAMAGE TO PROPERTY, DIRECT, INCIDENTAL, OR CONSEQUENTIAL, ARISING OUT OF THE USE OF, OR INABILITY TO USE THE MANUFACTURER'S PRODUCTS. FURTHERMORE, THE MANUFACTURER SHALL NOT BE LIABLE FOR ANY PERSONAL INJURY OR DEATH WHICH MAY ARISE IN THE COURSE OF, OR AS A RESULT OF, PERSONAL, COMMERCIAL, OR INDUSTRIAL USE OF ITS PRODUCTS.

This warranty replaces all previous warranties and is the only warranty made by the manufacturer. No increase or alteration, written or verbal, of the obligation of this warranty is authorized.



World Headquarters
One Fire-Lite Place, Northford, CT 06472-1653 USA
203-484-7161 • Fax 203-484-7118
www.firelite.com

ISO 9001
CERTIFIED
ENGINEERING & MANUFACTURING