



A Division of Pittway  
 3825 Ohio Avenue, St. Charles, Illinois 60174  
 1-800-SENSOR2, FAX: 630-377-6495

# 6424 Projected Beam Type Smoke Detector

## Specifications

### General

Range: 30 to 330 Feet  
 Sensitivity: 30% ± 5% Total Obscuration, or  
 55% ± 5% Total Obscuration  
 Response Time: Alarm: 15 Seconds Max.  
 Trouble: 15 Seconds Max.  
 Trouble Condition: 95% or More Obscuration  
 Improper Initial Alignment  
 Self-compensation limit reached (service needed)  
 Test/Reset Features: Obscuration Filters (ALARM/NO ALARM)  
 Local Alarm Reset Switch  
 Remote Test and Reset Switch Capability  
 (compatible with RTS451 Test Station with Magnet)  
 Indicators: Alarm: Remote Output, Local LED (red)  
 Trouble: Remote Output, Local LED (yellow)  
 Normal Operation: Local LED (flashing green)  
 Alignment Aid: LED Bar Graph (4 red LEDs)  
 Alarm; Trouble

### Relays:

### Environmental

Temperature: -30° C to 55° C (-22° F to 131° F)  
 Humidity: 10% to 93% RH Noncondensing

### Mechanical

Weight: Receiver: 1.5 lbs (663 g)  
 Transmitter: 1.3 lbs (598 g)  
 Mounting: Ceiling or Wall, Separate Mounting Brackets Provided  
 Wiring: Plug with Attached Cable  
 Adjustment Angle: Ceiling: ± 30° Horizontal/60° Vertical  
 Wall: ± 90° Horizontal/60° Vertical

### Electrical (Receiver)

Voltage: 20 to 32 VDC  
 Maximum Ripple Voltage: 6.0 volts (Peak-to-peak)  
 Current (24 VDC): Avg. Standby: 10mA Max.  
 Avg. Alarm: 28.4mA Max.  
 Avg. Trouble: 27.1mA Max.  
 Start-up Surge: 19mA Max.  
 Relay Contacts: .5A at 30 VAC/DC  
 Reset Time: .6 Seconds Max.  
 Start-up Time (after 5 min. reset): 1 Minute Maximum  
 Power Loss: Retain Memory for 5 Minute Minimum

### Electrical (Transmitter)

Voltage: 18.8 to 32 VDC  
 Maximum Ripple Voltage: 5.6 volts (Peak-to-Peak)  
 Avg. Current (24 VDC): 10mA Max.

## Before Installing

Please thoroughly read this manual and applicable sections of System Sensor's Manual I56-506, *Guide for Proper Use of Projected Beam Detectors*. Copies of this manual are available from System Sensor.

## General Description

System Sensor Model 6424 is a long range projected beam smoke detector designed to provide open area protection. It is to be used with UL-listed, separately supplied power (4-wire) control panels only. The detector consists of a separate transmitter and receiver. Smoke entering the area between the transmitter and receiver causes a reduction in signal at the receiver. When the obscuration reaches one of two predetermined thresholds (chosen with a switch in the receiver), the detector generates an alarm signal. Complete blockage of the beam causes a trouble signal to avoid false alarms. Slow changes in obscuration due to a build up of dirt or dust on the lens of the detector are compensated for by a microcontroller which continuously monitors the signal strength and periodically updates the alarm and trouble thresholds. When the self-compensation circuit reaches its limit, the detector generates a trouble signal, indicating the need for service.

Three LEDs at the receiver indicate the status of the detector: a red LED for alarm, a yellow LED for trouble, and a pulsed green LED for standby operation. The alarm signal latches and can be reset by a momentary power interruption, by using the remote reset input to the receiver if using the remote test/reset station model RTS451, or with the local reset button located behind the rear door in the receiver. A trouble signal automatically resets upon removing the cause of trouble. In addition to these indicators, there are four LEDs on both the receiver and the transmitter which are used as a beam alignment aid. No additional equipment is needed for alignment of the beam.

Each detector contains one Form A (normally open) contact for alarm signals and one Form B (normally closed) contact for trouble signals. Supervision of power is accomplished by installing a Power Supervisory End-of-Line Relay Module (model A77-716) at the end of the detector power loop. When power is applied to and through the detectors, the EOL Power Supervisory Module is energized. The relay contacts, along with the detector's trouble relay contacts, can provide a closed series circuit in the control panel's alarm-initiating loop. A loss in power or a trouble condition at the detector causes the respective EOL or trouble relay to open, resulting in a trouble signal at the control panel.

## Parts List

Description	Quantity
Receiver Unit	1
Transmitter Unit	1
Receiver Wiring Cable	1
Transmitter Wiring Cable	1
Wall Mounting Bracket	2
Ceiling Mounting Bracket (inside part)	2
Ceiling Mounting Bracket (outside part)	2
Wall Bracket Screw	2
Ceiling Bracket Screw	2
Washers	4
Allen Wrench	1
Instruction Manual	1
Test Filter	1
Cable Exit Plug	1
Hole Plug	1

## Detector Placement

This section of the manual discusses the placement of projected beam detectors. Though this information is based upon industry expertise, it is intended to be used only as a technical guide. Always comply with the requirements of applicable codes and standards such as, NFPA 72, National Fire Alarm Code, as well as directives of the Authority Having Jurisdiction (AHJ). For general information on the placement of detectors, read System Sensor's Manual I56-506, *Guide for Proper Use of Projected Beam Detectors*.

Projected beam detectors are usually located with their beams parallel to the ceiling. However, they can be mounted vertically or at any angle to protect the area involved. Since beam detectors sense the smoke buildup over a distance, they are ideal for locations with high ceilings. They can also be mounted on a wall or ceiling below the level of a spot type detector, reducing the effects of air stratification. Some typical locations would include large areas with high ceilings such as atriums, warehouses, and factories.

**NOTE:** Projected beam smoke detectors should always be mounted to stable mounting surfaces. See the MOUNTING LOCATION section for details.

Some fire codes specify spacing on a given center-to-center distance between detectors under ideal conditions. These spacings are based on rooms with smooth ceilings and no physical obstructions between the contents being protected and the detectors. Moreover, they are also based on a maximum ceiling height, and on the assumption that the value and the combustible nature of the contents of the room being protected do not warrant greater protection or closer spacing.

In a room with a smooth ceiling, detectors should be spaced between 30 and 60 feet. One-half that spacing between the beam and the sidewall may be used as a guide. See Figure 1. The beam detector can be mounted with the receiver on one wall and the transmitter on the opposite wall, or both suspended from the ceiling, or any wall/ceiling combination. In the case of the ceiling mount, the distance from the end walls should not exceed one-quarter of the selected spacing (7.5 ft. maximum if the spacing is 30 ft.). See Figure 2.

Figure 1. Spacing for smooth ceiling (side view):

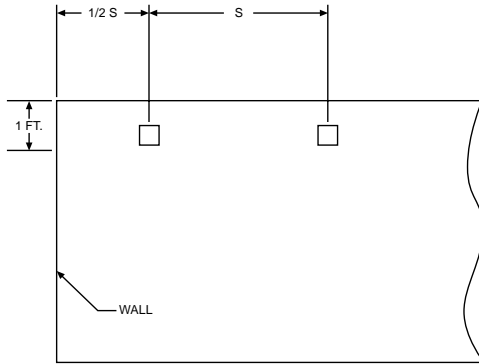

A78-2037-00

Figure 2. Spacing for smooth ceiling (top view):

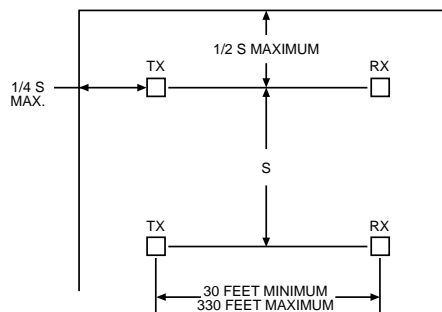

A78-2039-00

In the case of peaked or sloped ceilings, codes may specify spacing of detectors by using horizontal spacing from the peak of the roof or ceiling. Figures 3 and 4 show the spacing for both the shed type and peaked type sloped ceilings.

Figure 3. Sloped ceiling (shed type):

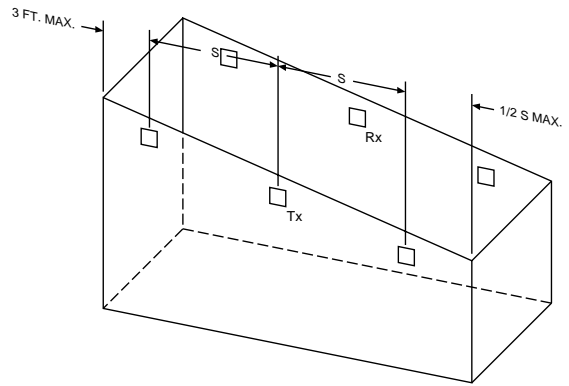

A78-2036-01

Figure 4. Sloped ceiling (peaked type):

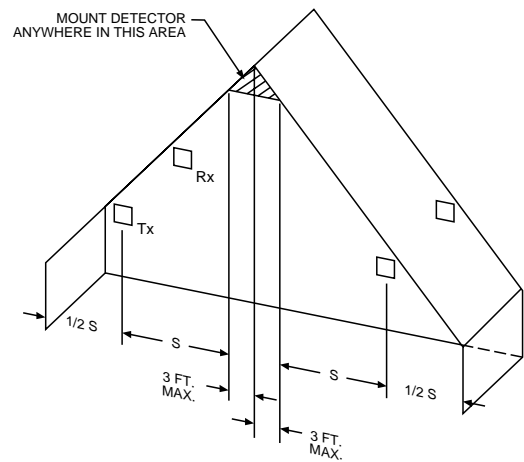

A78-2035-01

### Mounting Locations

Beam detectors require a stable mounting surface for proper operation. A surface which moves, shifts, vibrates, or warps over time will cause false alarm or trouble conditions. Initial selection of a proper mounting surface will eliminate false alarms and nuisance trouble signals.

Mount the detector on a stable mounting surface, such as brick, concrete, a sturdy load-bearing wall, support column, structural beam, or other surface that is not expected to experience vibration or movement over time. **DO NOT MOUNT** the beam detector on corrugated metal walls, sheet metal walls, external building sheathing, external siding, suspended ceilings, steel web trusses, rafters, nonstructural beam, joists, or other such surfaces.

Figure 5. Good and poor mounting surfaces:

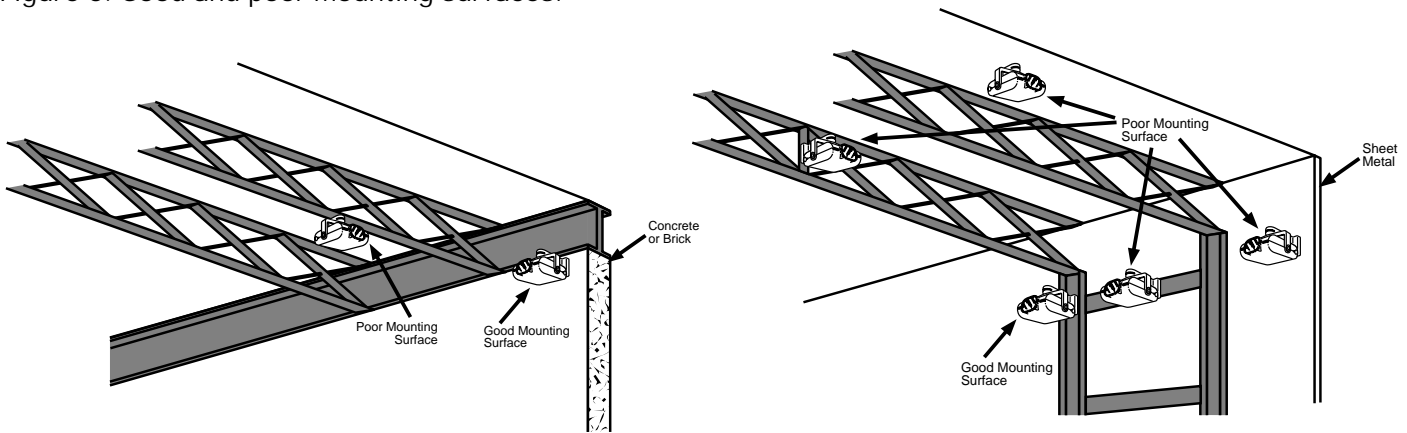

A78-2652-00

### Mounting Brackets

Install a ceiling or wall bracket for both the receiver and transmitter so that when mounted, the receiver and the transmitter will be at approximately the same height. Each ceiling bracket is composed of two parts that should be assembled with inside part between the ceiling and outside part as shown in Figure 5. The brackets should be mounted so that the slot in the front of each bracket is facing the other bracket. Mount the brackets only on solid structures of the building. To avoid unwanted alarms due to wall movement, do not mount to flexible walls, such as sheet metal walls (see MOUNTING LOCATIONS). Mount brackets with a separation of at least 30 feet but not more than 330 feet.

Figure 6. Ceiling mounting bracket assembly:

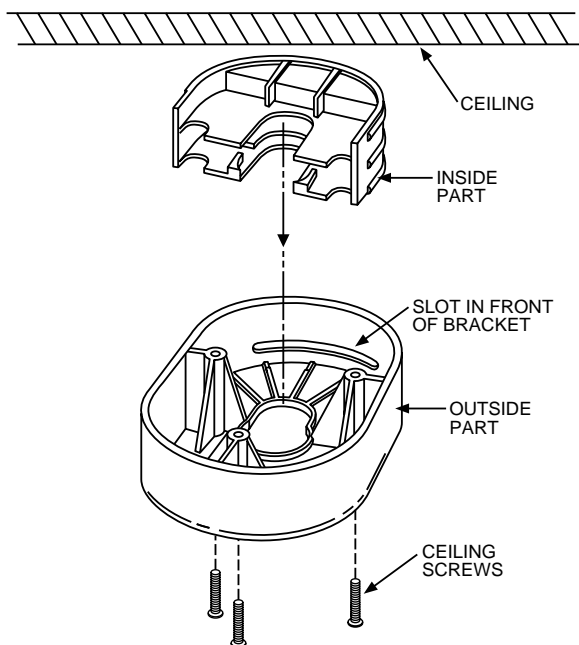

A78-2041-01

### Wiring Installation Guidelines

Always install all wiring in compliance with the National Electrical Code, and/or the applicable local codes, and any special requirements of the local authority having jurisdiction. Proper wire gauges and suitable means for strain relief should be used. The conductors used to connect beam smoke detectors to control panels and accessory devices should be color-coded to reduce the likelihood of wiring errors. Improper connections can prevent a system from responding properly in the event of a fire.

Installation wire used for the beam detector shall be no smaller than 18 gauge (1.0 square mm). For best system performance, all wiring should be twisted pair and installed in separate grounded conduit. Do NOT mix fire system wiring in the same conduit as any other electrical wiring. Shielded cable may be used to provide additional protection against electrical interference.

When installing the beam smoke detector in applications where flexible conduit will be used the BMB Beam Mounting Bracket kit must be installed with the cable before wiring the unit, as per the instructions supplied with the kit. For applications that require flexible conduit to be mounted to the beam smoke detector, the model BMB kit can be ordered separately.

In those applications where the model BMB kit is not used, the two connectors with attached cable (6 conductor for the transmitter and 16 conductor for the receiver) can be wired before the detector is mounted.

For wiring, first remove the pre-cut insulation from the conductor to be connected, then use a wire nut to connect the detector wire to the field wire. If the insulation has been removed from any unused conductors, make sure they are terminated properly to avoid short circuits. The transmitter can be wired in one of two ways. Figure 7 shows the transmitter permanently connected to the receiver. In this case the transmitter receives its power along with communication for the alignment aid through the connecting pair of

wires. Figure 8 shows an alternative wiring configuration in which the transmitter receives its power from a remote power source. Temporary wiring can be installed for the communication needed for transmitter alignment aid. If the remote power configuration is used, the remote power source must comply with all codes and directives of the Authority Having Jurisdiction. NOTE: The transmitter

should be permanently wired to the receiver (Figure 7) whenever possible to allow the alignment LEDs on the transmitter to be used during the alignment procedure. Figure 9 shows the remote outputs for trouble and alarm, while Figure 10 shows the connection necessary for using the remote test station (RTS451 or RTS451KEY).

Figure 7. Transmitter permanently wired to receiver:

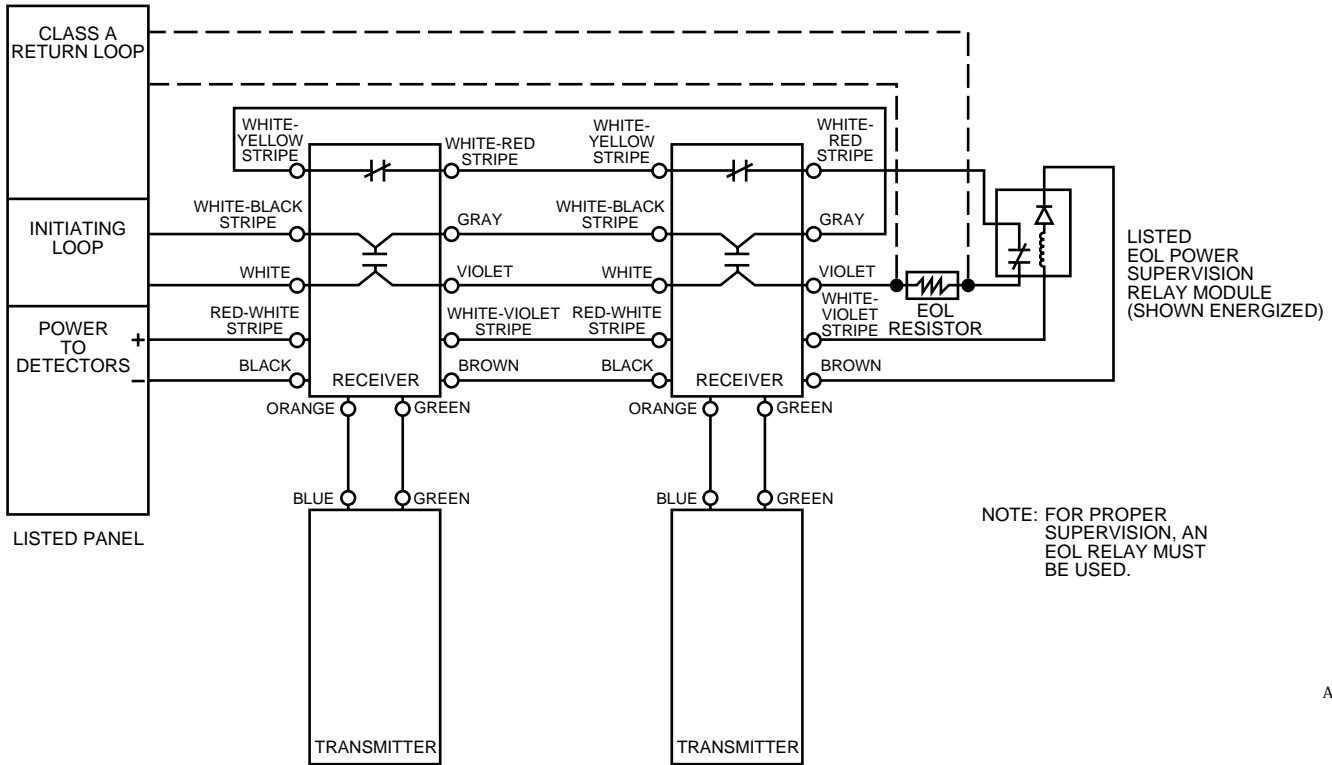

A78-2043-00

Figure 8. Transmitter powered separately:

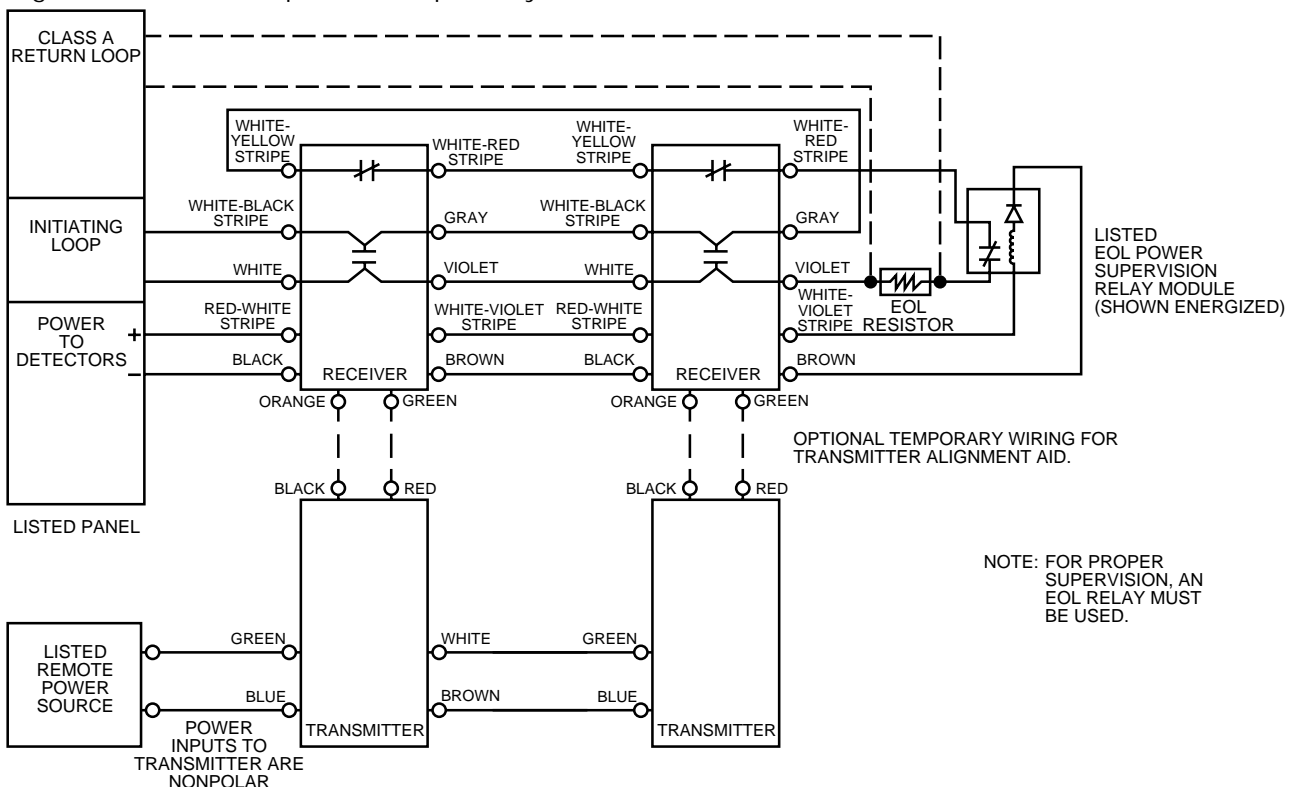

A78-2042-00

**NOTE:** The test coil which is shipped with the RTS451 and RTS451KEY is not used on the 6424 Beam Smoke Detector.

Figure 9. Remote annunciators:

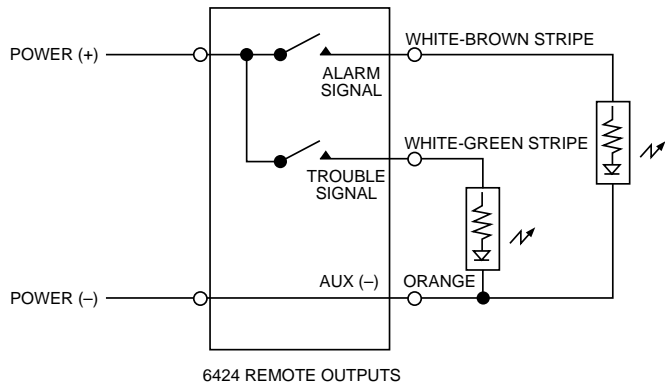

A78-2040-00

Figure 10. Remote Test Station:

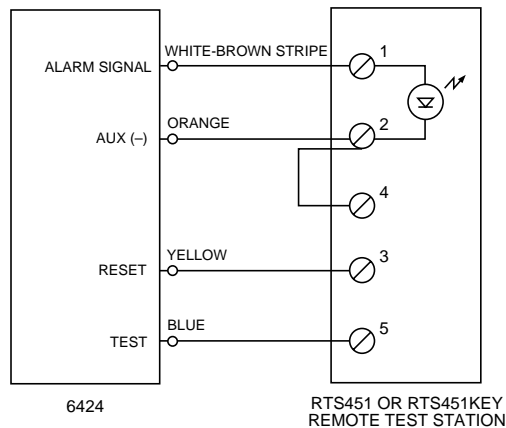

A78-2038-01

## Installation

**Reference Figures 11 through 17 for installation, alignment, and maintenance.**

### **▲WARNING**

Disconnect the power from the initiating device circuits before installing the detectors.

1. The clear protective film and warning label on the smoked lens of both the receiver and transmitter **MUST** be removed before they can operate. To remove them, grasp a free corner of the clear protective film and pull so that both the film and the warning label are peeled from the smoked glass lens.

2. Mount brackets and connect cables properly as detailed above. (In any applications where the BMB Beam Mounting Bracket kit is used, the kit should be installed before the detector is mounted. Instructions for mounting the BMB are included in the BMB kit.)
3. Insert the flange of the detector mounting bracket into the keyed hole of the wall or ceiling mounting bracket. Slide the detector forward into position. The detector should now hang from the bracket.
4. Insert the correct screw and washer combination (either wall or ceiling mount) through the slot and into the hole of the mounting bracket flange. Tighten the screw until almost snug. The detector should still turn easily in both directions.
5. Open the sliding access door on the back of the unit.
6. Plug cable connector into slot in metal barrier, observing proper orientation (see Figures 14 and 15).
7. Repeat for the other unit.
8. **IMPORTANT:** If the detector spacing is between 30 and 60 feet, the additional filter (included) must be attached to the receiver lens. Peel the protective backing off the filter and install as shown in Figure 11.

Figure 11. Additional filter required for installations with 30 to 60 Ft. spacing only:

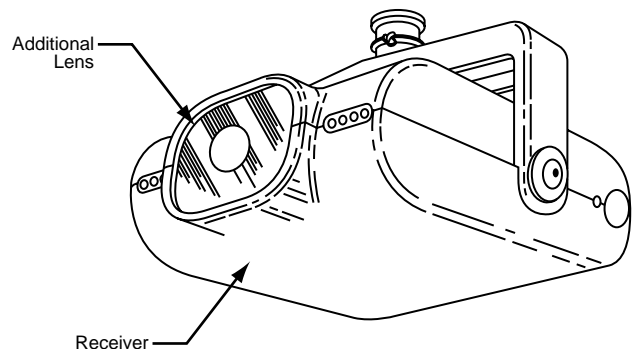

A78-2651-00

Figure 12. Wall mounting:

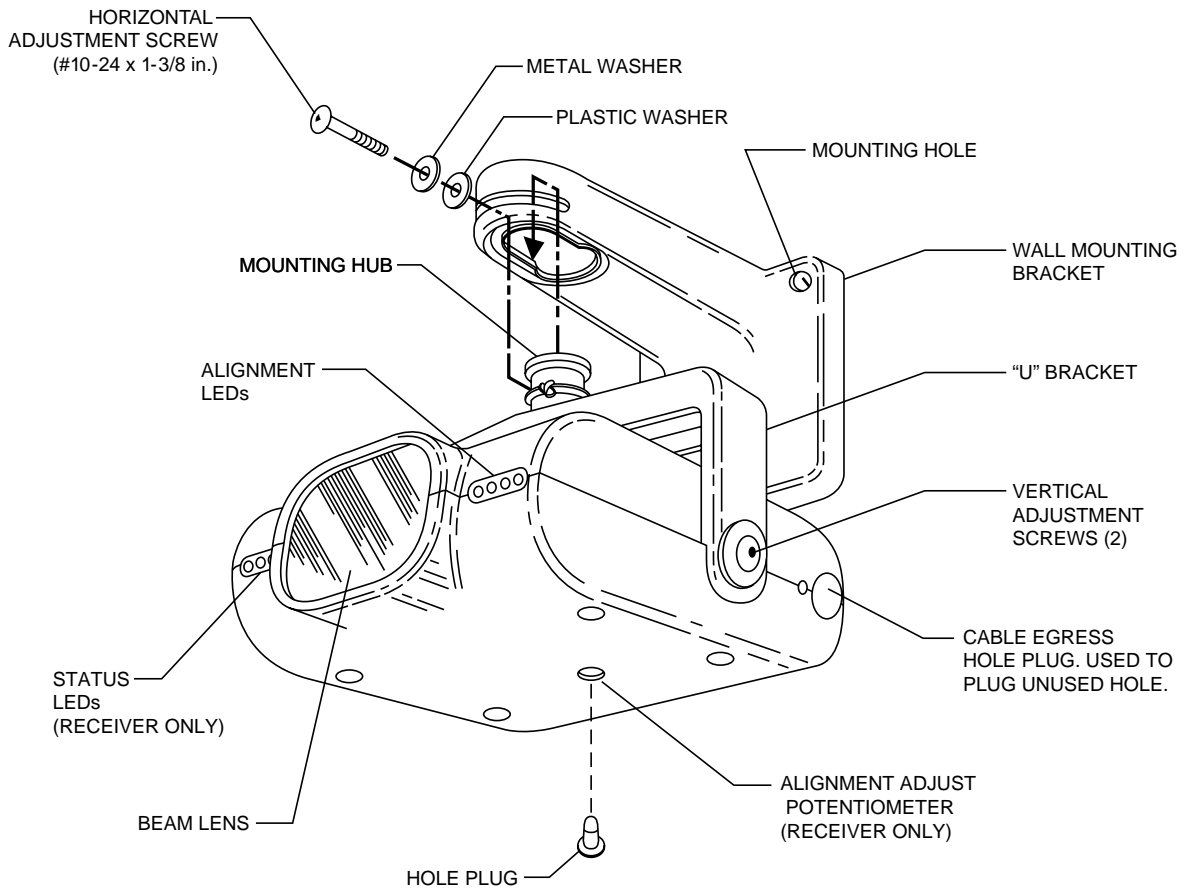

A78-2034-01

Figure 13. Ceiling mounting:

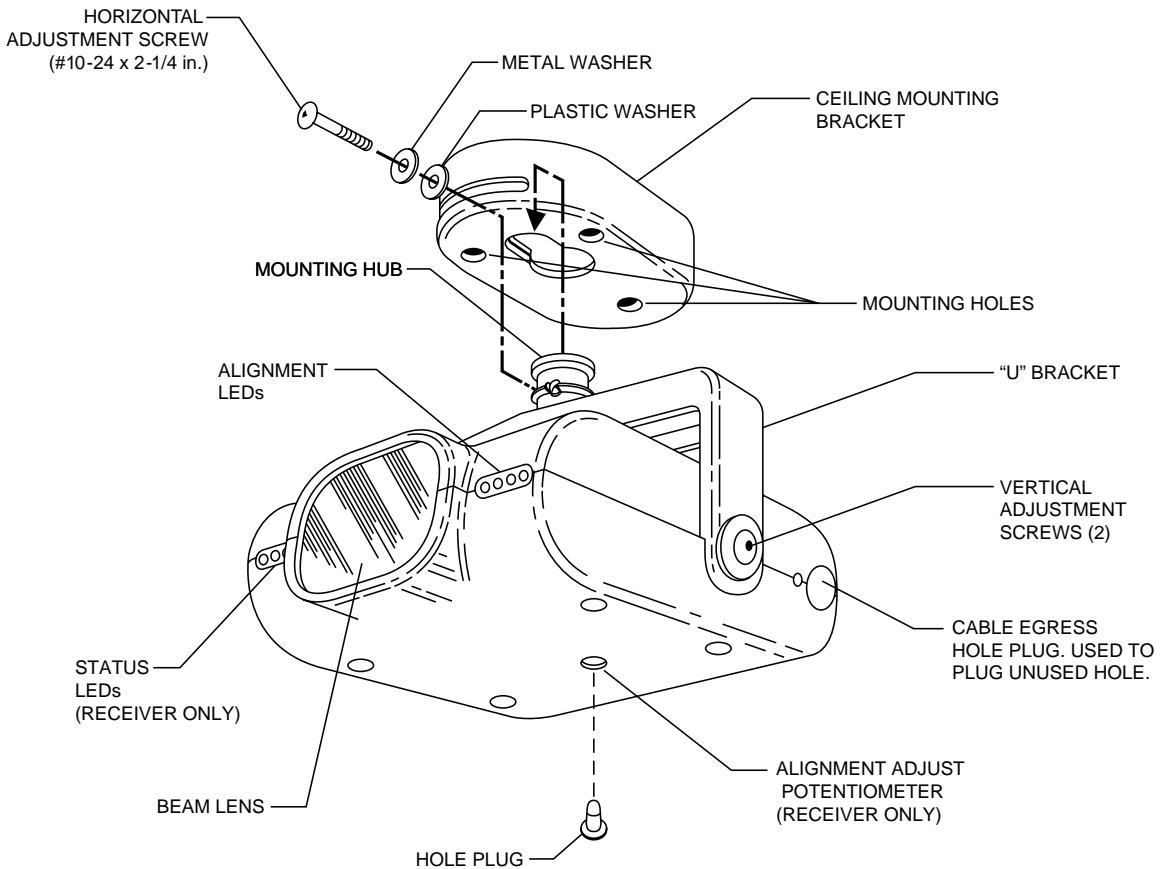

A78-2033-01

Figure 14. Rear view receiver:

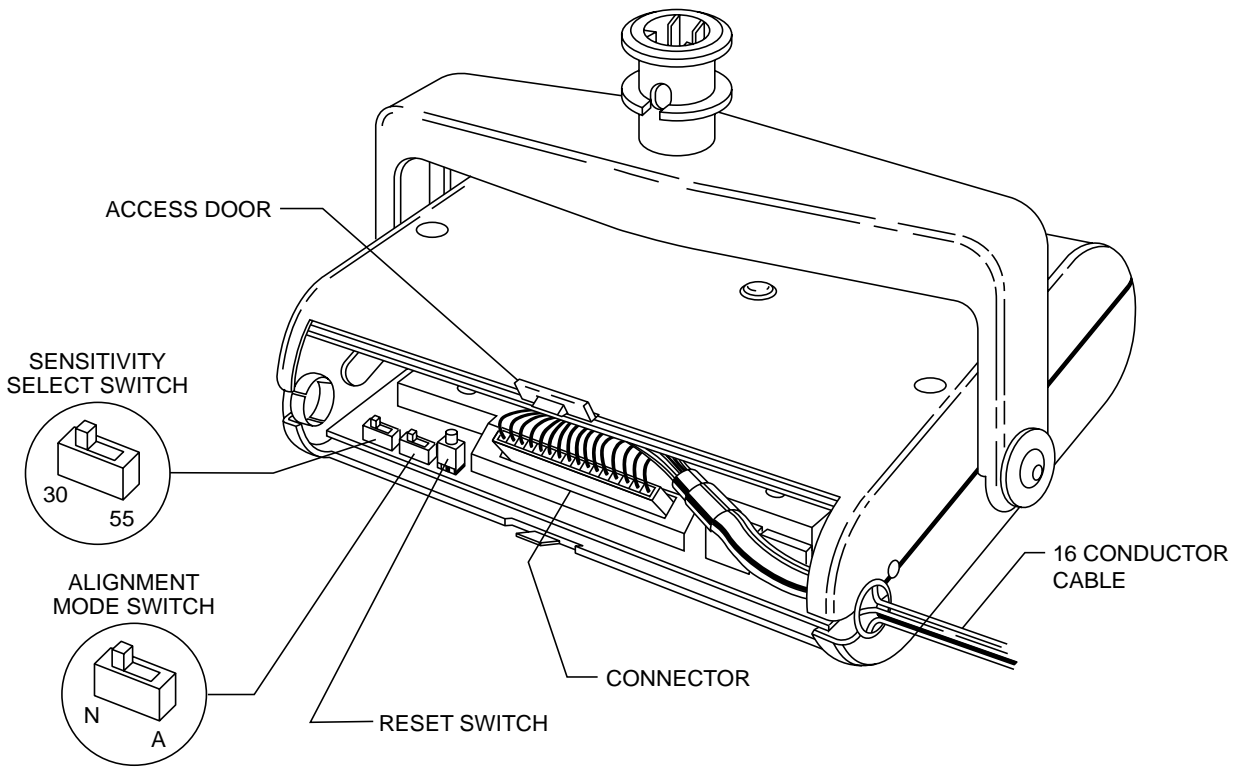

A78-2032-01

Figure 15. Rear view transmitter:

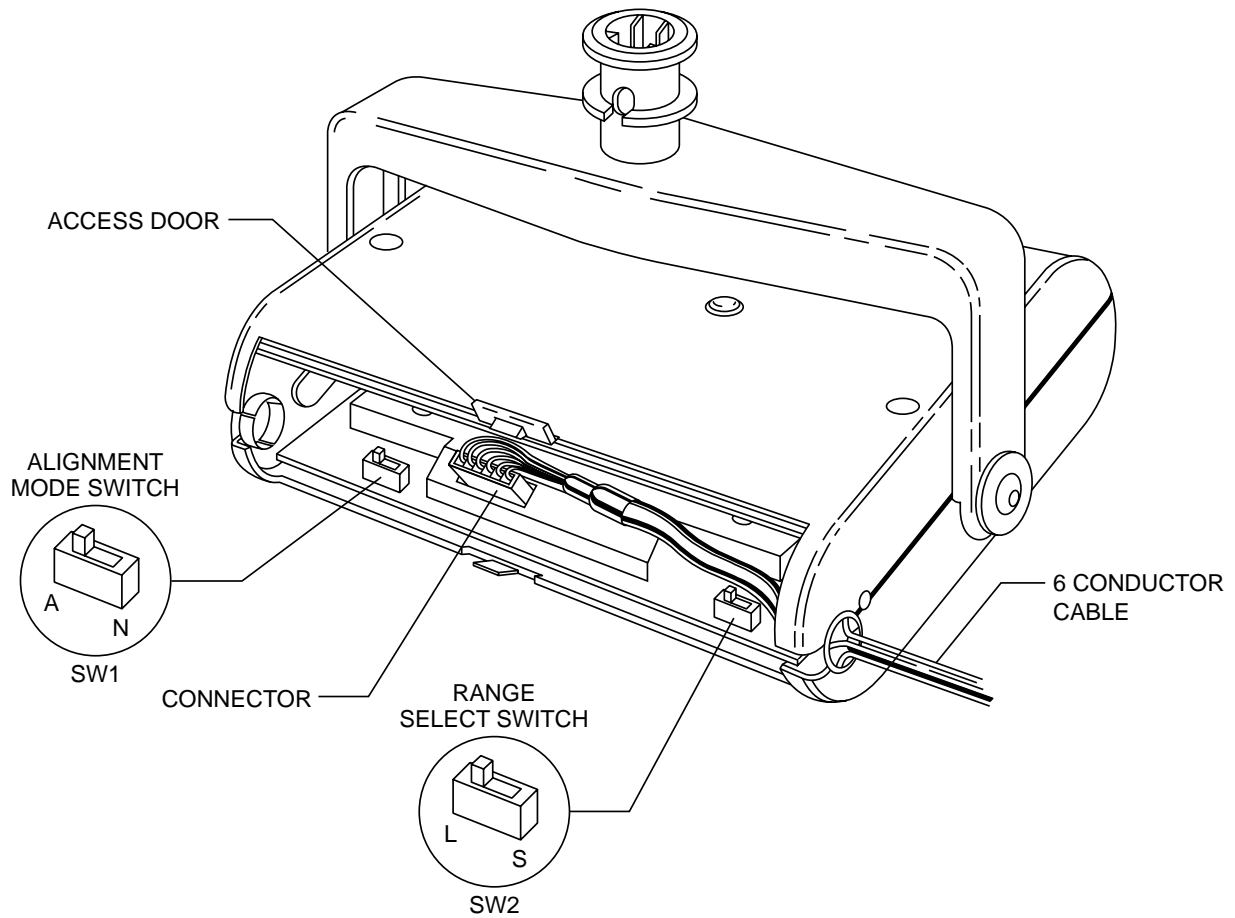

A78-2031-01



## Alignment

Figure 16. Front View Transmitter and Receiver

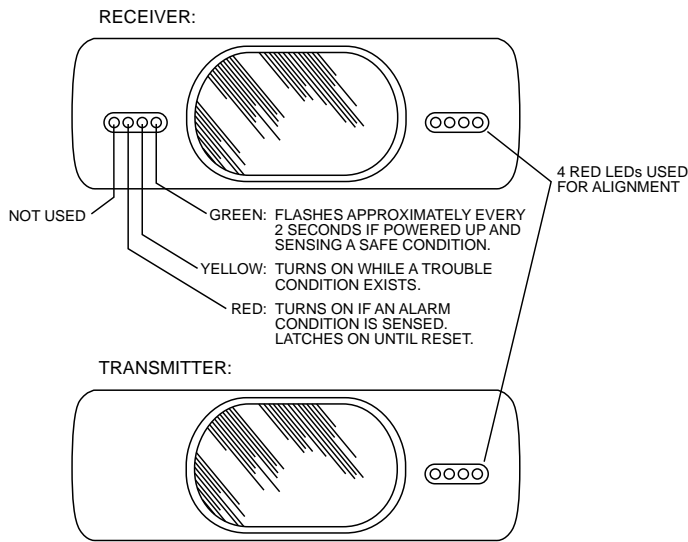

A78-2320-00

Figure 17. Alignment adjust pot (receiver only):

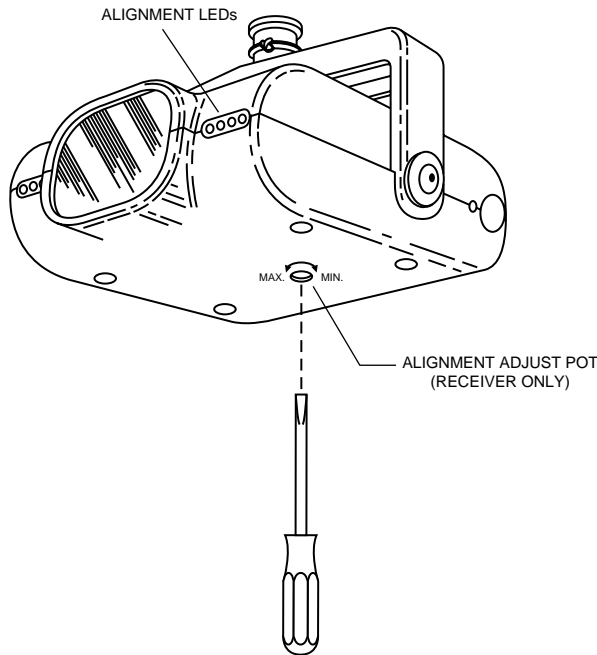

A78-2339-00

**CAUTION**

The clear protective film and warning label on the smoked lens of both the receiver and transmitter **MUST** be removed before they can operate.

The alignment of the 6424 is divided into three steps: alignment setup, alignment of the transmitter, and alignment of the receiver. It is necessary for all three steps to be executed properly to ensure proper alignment of the product. If the 6424 is mounted to a recommended surface (see MOUNT-

ING LOCATIONS) and alignment procedures are executed properly, false alarms and nuisance trouble signals will be avoided. The alignment procedure is best accomplished by two individuals. This allows the adjustment of the gain pot on the receiver during alignment of the transmitter without the need for several trips back and forth between the transmitter and receiver.

### A) ALIGNMENT SETUP:

- 1) At the transmitter, select the proper range using the range selection switch (SW2) on the transmitter.  
Short Range (S): 30 to 100 feet  
Long Range (L): 100 to 330 feet
- 2) If the transmitter is directly wired to the receiver (Figure 7), slide the alignment switch (SW1) on the transmitter to the A (align) position (see Figure 15). Point the transmitter directly at the receiver, then go to step 5.
- 3) If the transmitter is wired directly to a power supply, it should be temporarily wired to the receiver if possible (see Figure 8). NOTE: Temporarily wiring the transmitter to the receiver is beneficial because it activates the alignment LEDs on the transmitter to allow alignment of the transmitter without having to look at the alignment LEDs on the receiver.
- 4) If the transmitter is not wired directly to the receiver, make sure the SW1 switch remains in the N (normal) position (see Figure 15) before going to step 5. Point the transmitter directly at the receiver.
- 5) At the receiver, select the proper sensitivity using the switch on the back of the receiver (see Figure 14). The sensitivity selected depends on the separation of the transmitter and receiver. The sensitivities and ranges shown are in accordance with UL standard 286, Smoke Detectors for Fire Protective Signaling Systems.

SENSITIVITY	DISTANCE
30%	30 to 92 feet
30% or 55% (30% is more sensitive)	92 to 178 feet
55%	178 to 330 feet

- 6) Using a small standard screwdriver, make sure the alignment adjust pot on the receiver (see Figure 17) is turned fully counterclockwise, looking at it from the bottom (maximum gain). The alignment adjust pot changes the gain of the amplifier to compensate for differences in separation between the receiver and transmitter and has no effect on the detector sensitivity.

- 7) Turn on power to the system.
- 8) Slide the alignment switch on the receiver to A (see Figure 14). The yellow trouble LED should light to indicate alignment mode, but the trouble relay will not activate. If the receiver is left in the alignment mode for more than an hour, the trouble relay will activate.
- 9) Point the receiver directly at the transmitter.

**B) RECEIVER ALIGNMENT PROCEDURE:**

- 1) Align the receiver by slowly moving it back and forth, and up and down until all four LEDs light. (NOTE: If it is impossible to get all four LEDs to light, the transmitter may need to be adjusted. Go to the transmitter and align it so that all four LEDs light, and then go back to the receiver and continue with step 2.)
- 2) Adjust the alignment adjust pot until only three alignment LEDs are lit.
- 3) Further align the receiver by slowly moving it back and forth, and up and down, trying to get all four LEDs to light.

REPEAT STEPS 2 AND 3 UNTIL IT IS IMPOSSIBLE TO GET MORE THAN THREE LEDs TO LIGHT. (NOTE: If steps 2 and 3 are carefully executed, it should take two to five tries to align the receiver.)

- 4) Carefully tighten the horizontal adjustment screws first and then the two vertical adjustment screws on the receiver bracket, making sure all three alignment LEDs remain lit.

**C) TRANSMITTER ALIGNMENT PROCEDURE:**

- 1) Slowly move the transmitter back and forth, and up and down, trying to get all four LEDs to light.
- 2) If four LEDs light, adjust the alignment adjust pot on the receiver until only three alignment LEDs are on.

REPEAT STEPS 1 AND 2 UNTIL IT IS IMPOSSIBLE TO GET MORE THAN THREE LEDs TO LIGHT. (NOTE: If steps 1 and 2 are carefully executed, it should take between two and five tries to achieve this.)

- 3) When it is impossible to get more than three LEDs to light, carefully tighten the horizontal adjustment screws and then the vertical adjustment screws on the transmitter bracket, making sure all three alignment LEDs stay lit.

- 4) Slide the alignment switch on the transmitter to the NORMAL MODE (N) position (see figure 15) and disconnect any temporary wiring. Carefully close the door on the transmitter and go to the receiver.
- 5) Verify that three alignment LEDs are lit and switch back to NORMAL MODE (N) at the receiver. It is important that three alignment LEDs are on (not four) when leaving alignment mode. This ensures that the amplifier is not saturated with signal and will be capable of detecting smoke within its sensitivity limits. Wait at least one minute before continuing. Do not block or disturb the beam while it is calibrating. Any interference could cause a trouble signal. If there is a trouble signal during this period, switch the receiver back to ALIGN MODE to make sure that only three LEDs are lit. Switch back to NORMAL MODE and wait again. If three alignment LEDs are not on, repeat the transmitter alignment procedure.
- 6) When the detector has completed its self-calibration, the green (normal) operation LED will flash every two or three seconds. Alignment is now complete.

**Sensitivity**

Total obscuration can be converted to percent per foot, assuming uniform smoke density for the entire length of the beam. The chart below converts total obscuration to percent per foot at both 30% and 55% sensitivity settings.

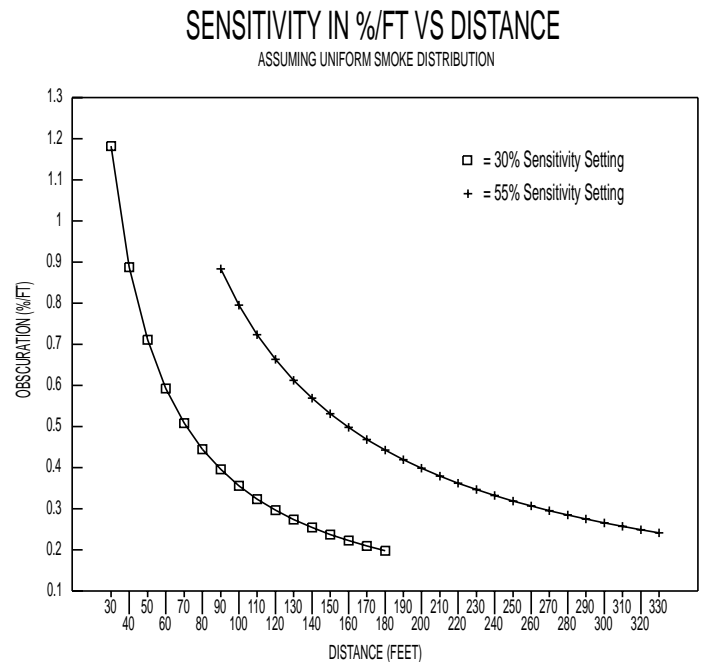

A78-2321-00

## Sensitivity Testing

**NOTE:** Before testing, notify the proper authorities that the smoke detector system is undergoing maintenance, and therefore the system will be temporarily out of service. Disable the zone or system undergoing maintenance to prevent unwanted alarms.

Detectors must be tested after installation and following periodic maintenance. The sensitivity of the 6424 may be tested as follows:

**NOTE:** Before testing the detector, check for the presence of the flashing green LED at the receiver, making sure not to disturb or block the beam. If it does not flash and the detector is not in trouble or alarm, power has been lost to the detector (check the wiring).

### A. Calibrated Test Filter

1. Test the detector at the receiver.
2. Use the proper side of the test card depending on the sensitivity setting (55 or 30) of the detector.
3. Place the NO ALARM section of the test filter over the receiver lens. The green LED should continue to pulse and the detector should not alarm after 15 seconds.
4. Place the ALARM section of the test filter over the lens. The detector should alarm within 15 seconds.
5. The detector can be reset with the local reset, remote reset, or by momentarily interrupting the power.
6. Notify the proper authorities that the system is back on line.

Detectors that fail to alarm should be returned for repair. Units that alarm during the non-alarm test (step 3) should be cleaned and tested again before being returned. Follow the maintenance instructions for cleaning.

### B. Remote Test Switch

The remote test station, RTS451, can be used with the 6424 beam smoke detector. Follow instructions included with the test station for proper use. See Figure 9 (Remote Test Station) for wiring diagram.

If the detector is not in trouble and the unit fails to alarm, check all related wiring. Once the proper wiring is confirmed, perform the above calibrated test filter procedure. If the unit still fails to alarm it should be returned for repair.

## Maintenance

**NOTE:** Before cleaning the detector lenses, notify the proper authorities that the smoke detector system is undergoing maintenance, and therefore the system will be temporarily out of service. Disable the zone or system undergoing maintenance to prevent unwanted alarms.

1. Carefully clean the lenses of both the receiver and the transmitter. A damp soft cloth with a mild soap may be used. Avoid products with solvents or ammonia.
2. After the lenses are clean, switch the receiver to the align mode. If three and only three alignment LEDs turn on, slide the align switch back to normal mode and wait approximately one minute for self calibration. The green LED should pulse after the calibration time. If more or fewer LEDs turn on in align mode, see the Beam Alignment Instructions on page 9 for realignment.
3. Notify the proper authorities that the system is back on line.

## Please refer to insert for the Limitations of Fire Alarm Systems

### Three-Year Limited Warranty

System Sensor warrants its enclosed smoke detector to be free from defects in materials and workmanship under normal use and service for a period of three years from date of manufacture. System Sensor makes no other express warranty for this smoke detector. No agent, representative, dealer, or employee of the Company has the authority to increase or alter the obligations or limitations of this Warranty. The Company's obligation of this Warranty shall be limited to the repair or replacement of any part of the smoke detector which is found to be defective in materials or workmanship under normal use and service during the three year period commencing with the date of manufacture. After phoning System Sensor's toll free number 800-SENSOR2 (736-7672) for a Return Authorization number, send defective units postage prepaid to: System Sensor, Repair Depart-

ment, RA # \_\_\_\_\_, 3825 Ohio Avenue, St. Charles, IL 60174. Please include a note describing the malfunction and suspected cause of failure. The Company shall not be obligated to repair or replace units which are found to be defective because of damage, unreasonable use, modifications, or alterations occurring after the date of manufacture. In no case shall the Company be liable for any consequential or incidental damages for breach of this or any other Warranty, expressed or implied whatsoever, even if the loss or damage is caused by the Company's negligence or fault. Some states do not allow the exclusion or limitation of incidental or consequential damages, so the above limitation or exclusion may not apply to you. This Warranty gives you specific legal rights, and you may also have other rights which vary from state to state.

### FCC Statement

This device complies with part 15 of the FCC Rules. Operation is subject to the following two conditions: (1) This device may not cause harmful interference, and (2) this device must accept any interference received, including interference that may cause undesired operation.

Note: This equipment has been tested and found to comply with the limits for a Class B digital device, pursuant to Part 15 of the FCC Rules. These limits are designed to provide reasonable protection against harmful interference in a residential installation. This equipment generates, uses and can radiate radio frequency energy and, if not installed and used in accordance with the instructions, may cause harmful interference to radio communications. However, there is no guarantee that interference will not occur in a particular installation. If this equipment does cause harmful interference to radio or television reception, which can be determined by turning the equipment off and on, the user is encouraged to try to correct the interference by one or more of the following measures:

- Reorient or relocate the receiving antenna.
- Increase the separation between the equipment and receiver.
- Connect the equipment into an outlet on a circuit different from that to which the receiver is connected.
- Consult the dealer or an experienced radio/TV technician for help.