

## MMX-1(A) MONITOR MODULE, CMX-2(A) CONTROL MODULE, AND ISO-X FAULT ISOLATOR MODULE INSTALLATION INSTRUCTIONS

This information is included as a quick reference installation guide. Refer to the appropriate Notifier Installation Manual for detailed system information. If the modules will be installed in an existing operational system, inform the operator and local authority that the system will be temporarily out of service. Disconnect power to the control panel before installing the modules.

**NOTICE:** This manual should be left with the owner/user of this equipment.

### GENERAL DESCRIPTION

**MMX-1(A) MONITOR MODULES** provide a two-wire, or four-wire fault-tolerant, initiating circuit for normally open contact fire alarm and supervisory devices, or either normally open or normally closed security devices. The LED indicator can be latched on or returned to the normal mode by code command from the panel. Rotary decade switches are used to set the address of each module.

**CMX-2(A) CONTROL MODULES** allow a compatible control panel to switch discrete contacts by code command. The control module offers a status LED that can be latched on or returned to the normal mode by code command from the panel. Rotary decade switches are used to set the address of each module.

The control module offers two modes of switching operation. As shipped, the module is configured for switching an external power source to notification appliances. The external power source can be a DC power supply or an audio amplifier (up to 70.7 Vrms). In this mode, the module reports supervision status of the connected loads to the control panel. Load circuit status is reported as a NORMAL, OPEN, or SHORTED circuit. Two pairs of output termination points are available for fault-tolerant wiring. The second mode of switching operation allows the panel to control one Form-C set of contacts. Circuit connections to the contacts are not supervised by the module. This mode is enabled by breaking two external tabs on the module.

**ISO-X FAULT ISOLATOR MODULES** enable part of the communications loop to continue operating when a short circuit occurs on it. An LED indicator blinks in the normal condition and turns on during a short circuit condition. The module will automatically restore the entire communications loop to the normal condition when the short circuit is removed.

### COMPATIBILITY REQUIREMENTS

To insure proper operation, these modules shall be connected to compatible Notifier system control panels only.

### MOUNTING MMX-1(A), CMX-2(A), AND ISO-X DEVICES

MMX-1(A), CMX-2(A), and ISO-X modules mount directly to 4 inch square electrical boxes as shown in Figure 2A. The box must have a minimum depth of 2<sup>1</sup>/<sub>8</sub>".

### WIRING

**NOTE:** All wiring must conform to applicable local codes, ordinances and regulations. When using control modules in nonpower limited applications, the CB500 Module Barrier must be used to meet UL requirements for the separation of power-limited and nonpower-limited terminals and wiring. The barrier must be inserted in a 4"x4"x2<sup>1</sup>/<sub>8</sub>" junction box, and the control module must be placed into the barrier and attached to the junction box (Figure 2A). The power-limited wiring must be placed into the isolated quadrant of the module barrier (Figure 2B).

1. Install module wiring in accordance with the job drawings and appropriate wiring diagrams (Figures 3 - 10).
2. Set the address on the module per job drawings.
3. Secure module to electrical box (supplied by installer), as shown in Figure 2A.

### MAGNET TEST

The monitor and control modules can be tested with a test magnet available from Notifier (M02-04-00, see Figure 1). The magnet test checks the module electronics and connections to the control panel. Interfaced initiating and indicating devices must be tested independently.

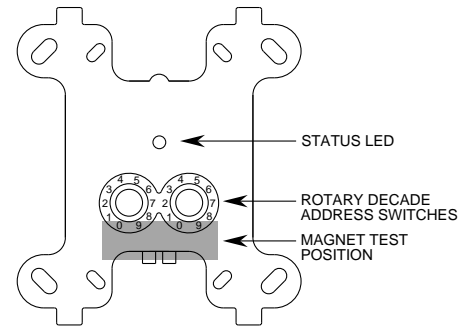

A78-2318-00

Figure 1. Monitor and Control Module Controls and Indicators

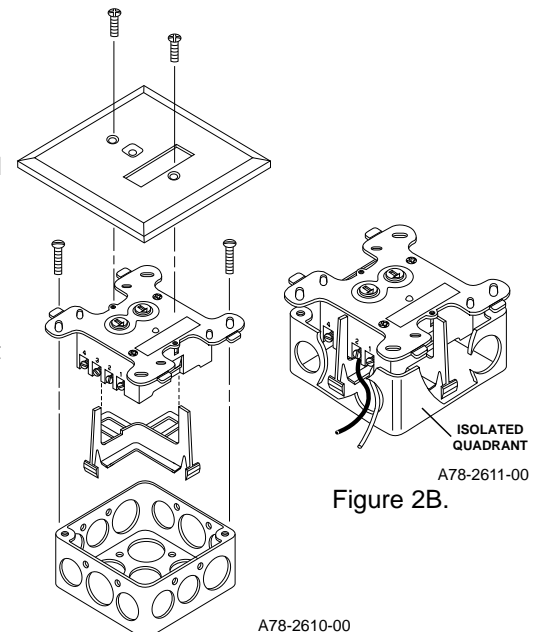

A78-2611-00

Figure 2B.

A78-2610-00

Figure 2A. Module Mounting with Barrier

## MMX-1(A) MONITOR MODULE WIRING DIAGRAMS

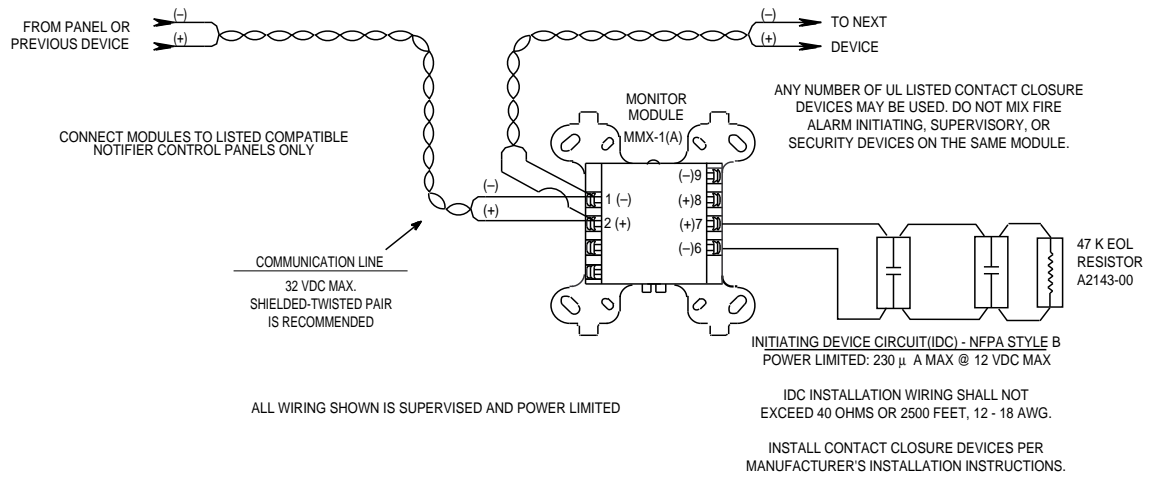

FIGURE 3. TYPICAL 2-WIRE INITIATING CIRCUIT CONFIGURATION, NFPA STYLE B

A78-2280-06

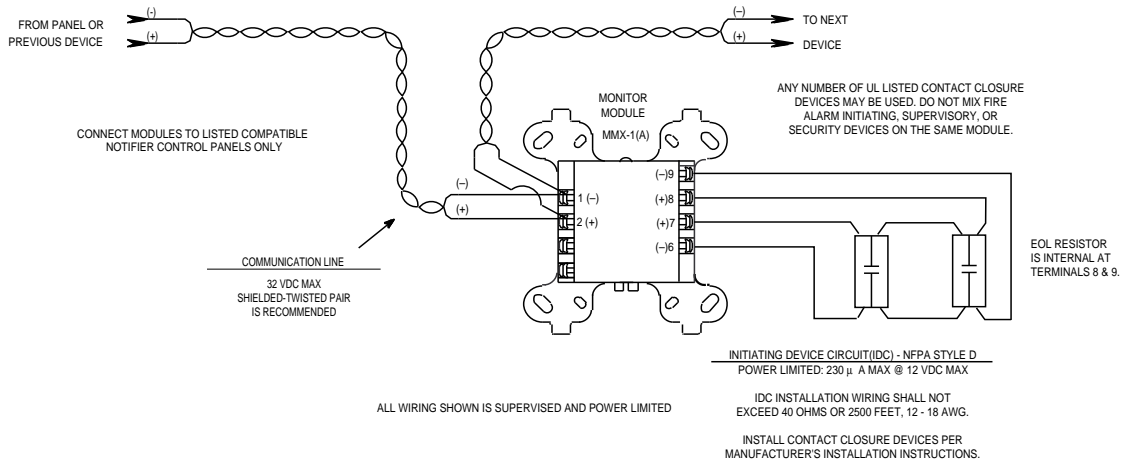

FIGURE 4. TYPICAL 4-WIRE FAULT TOLERANT INITIATING CIRCUIT CONFIGURATION, NFPA STYLE D

A78-2281-05

## CMX-2(A) CONTROL MODULE WIRING DIAGRAMS

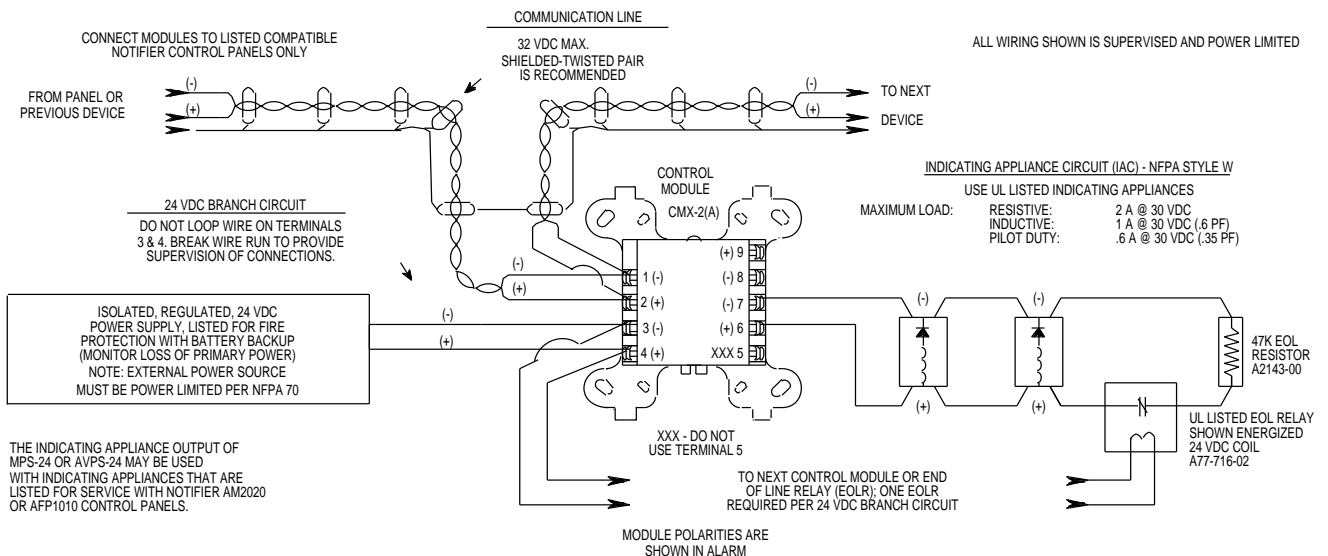
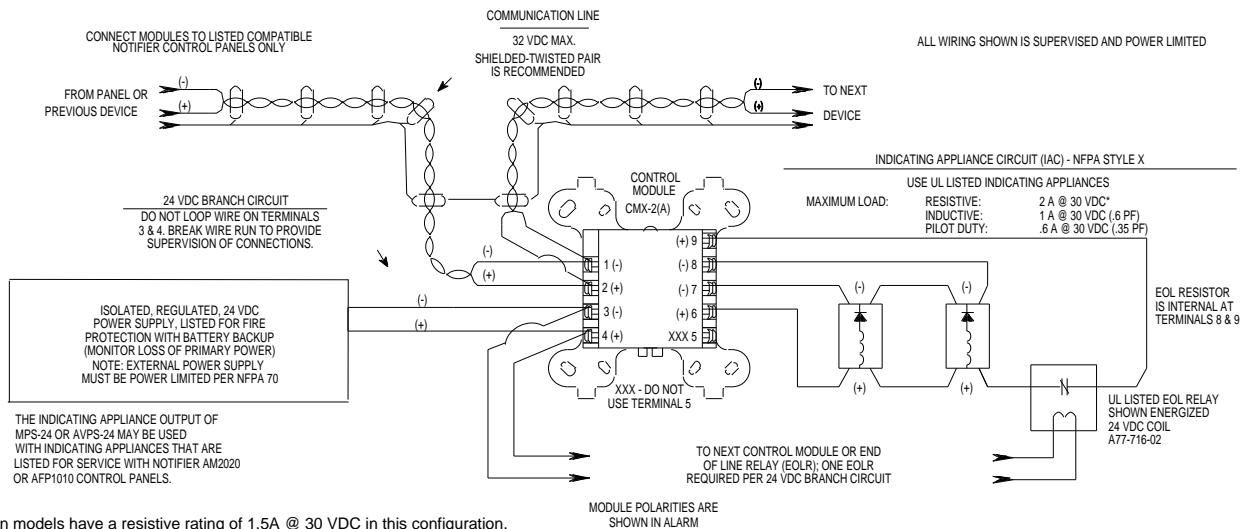

FIGURE 5. TYPICAL INDICATING CIRCUIT CONFIGURATION, NFPA STYLE W

A78-2282-22



\*Canadian models have a resistive rating of 1.5A @ 30 VDC in this configuration.

A78-2283-22

FIGURE 6. TYPICAL FAULT TOLERANT INDICATING CIRCUIT CONFIGURATION, NFPA STYLE X

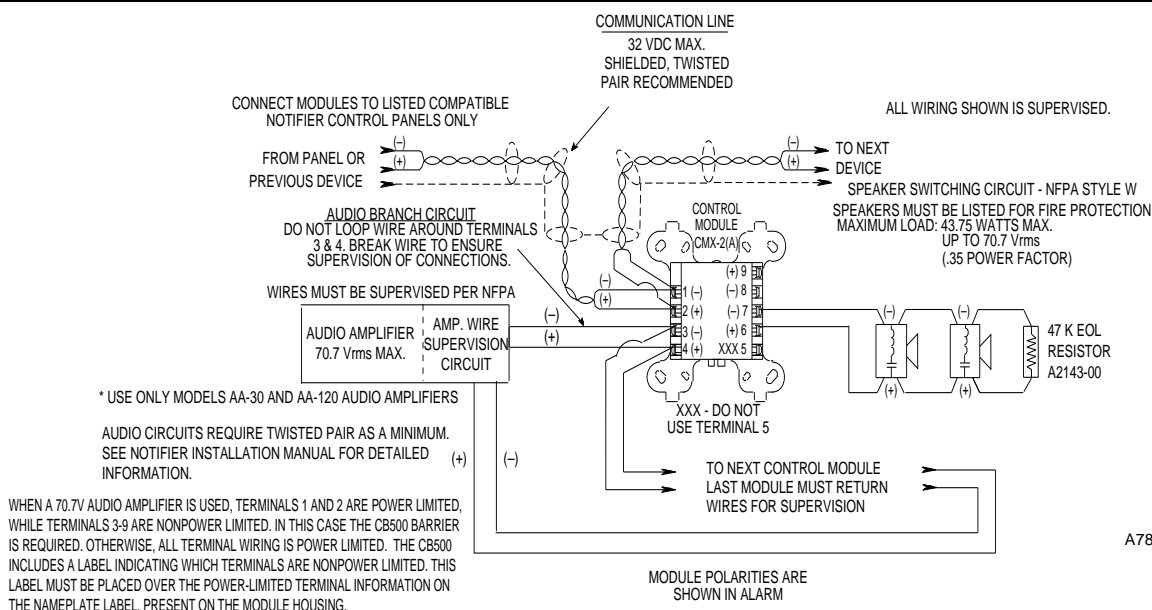

\* USE ONLY MODELS AA-30 AND AA-120 AUDIO AMPLIFIERS

AUDIO CIRCUITS REQUIRE TWISTED PAIR AS A MINIMUM. SEE NOTIFIER INSTALLATION MANUAL FOR DETAILED INFORMATION.

WHEN A 70.7V AUDIO AMPLIFIER IS USED, TERMINALS 1 AND 2 ARE POWER LIMITED, WHILE TERMINALS 3-9 ARE NONPOWER LIMITED. IN THIS CASE THE CB5000 BARRIER IS REQUIRED. OTHERWISE, ALL TERMINAL WIRING IS POWER LIMITED. THE CB5000 INCLUDES A LABEL INDICATING WHICH TERMINALS ARE NONPOWER LIMITED. THIS LABEL MUST BE PLACED OVER THE POWER-LIMITED TERMINAL INFORMATION ON THE NAMEPLATE LABEL, PRESENT ON THE MODULE HOUSING.

A78-2284-21

FIGURE 7. TYPICAL WIRING FOR SPEAKER SUPERVISION AND SWITCHING, NFPA STYLE W

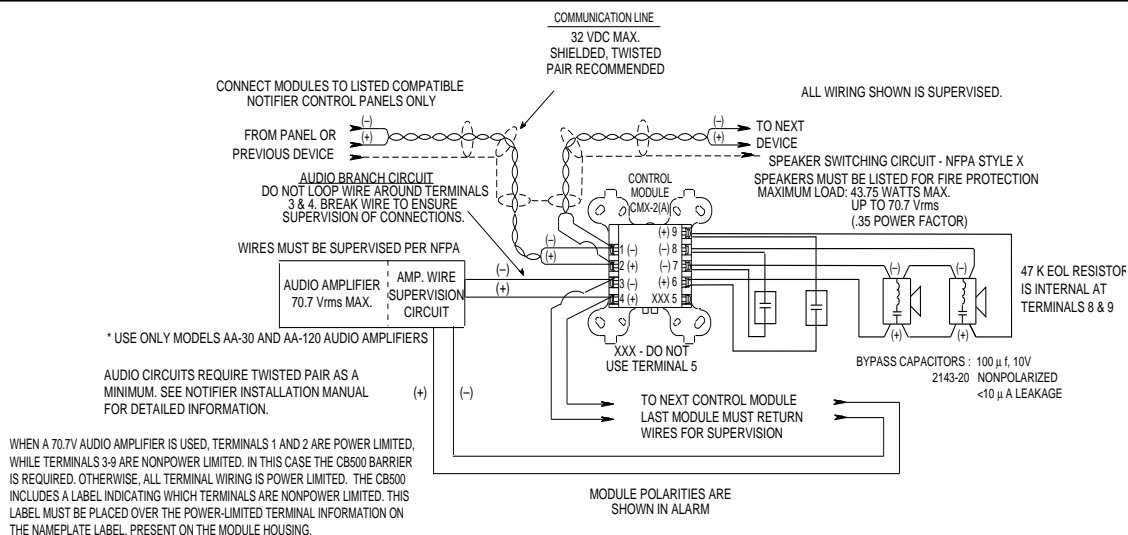

\* USE ONLY MODELS AA-30 AND AA-120 AUDIO AMPLIFIERS

AUDIO CIRCUITS REQUIRE TWISTED PAIR AS A MINIMUM. SEE NOTIFIER INSTALLATION MANUAL FOR DETAILED INFORMATION.

WHEN A 70.7V AUDIO AMPLIFIER IS USED, TERMINALS 1 AND 2 ARE POWER LIMITED, WHILE TERMINALS 3-9 ARE NONPOWER LIMITED. IN THIS CASE THE CB5000 BARRIER IS REQUIRED. OTHERWISE, ALL TERMINAL WIRING IS POWER LIMITED. THE CB5000 INCLUDES A LABEL INDICATING WHICH TERMINALS ARE NONPOWER LIMITED. THIS LABEL MUST BE PLACED OVER THE POWER-LIMITED TERMINAL INFORMATION ON THE NAMEPLATE LABEL, PRESENT ON THE MODULE HOUSING.

A78-2285-21

FIGURE 8. TYPICAL FAULT TOLERANT WIRING FOR SPEAKER SUPERVISION AND SWITCHING, NFPA STYLE X

