

The LED-10 Remote Fire Annunciator

*for use with the Fire-Lite
MS-5210UD
Fire Alarm Control Panel*

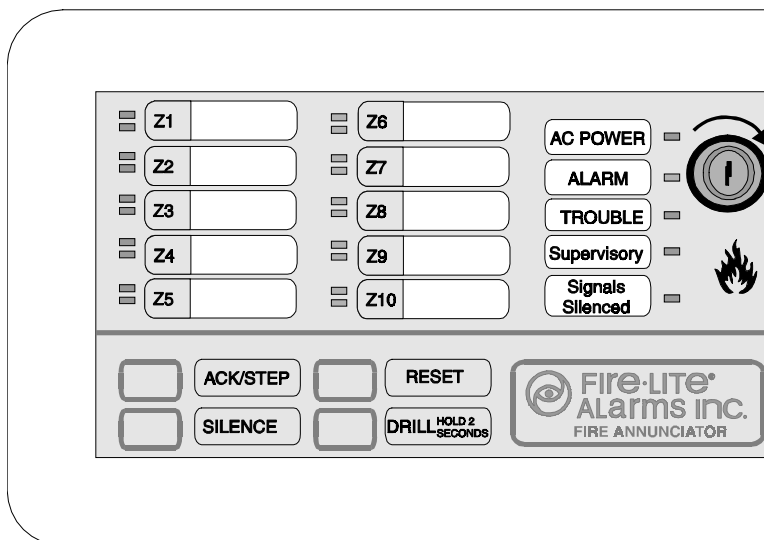

**Fire-Lite
Alarms Inc.**

12 Clintonville Road, Northford, CT 06472

Document # 50400
5/15/96 Revision: **A**
P/N 50400:A ECN 96-088

Installation Precautions

Adherence to the following will aid in problem-free installation with long-term reliability:

WARNING - Several different sources of power can be connected to the fire alarm control panel. Disconnect all sources of power before servicing. Control unit and associated equipment may be damaged by removing and/or inserting cards, modules, or interconnecting cables while the unit is energized. Do not attempt to install, service, or operate this unit until this manual is read and understood.

CAUTION - *System Reacceptance Test after Software Changes*: To ensure proper system operation, this product must be tested in accordance with NFPA 72-1993 Chapter 7 after any programming operation or change in site-specific software. Reacceptance testing is required after any change, addition or deletion of system components, or after any modification, repair or adjustment to system hardware or wiring.

All components, circuits, system operations, or software functions known to be affected by a change must be 100% tested. In addition, to ensure that other operations are not inadvertently affected, at least 10% of initiating devices that are not directly affected by the change, up to a maximum of 50 devices, must be tested and proper system operation verified.

This system meets NFPA requirements for operation at 0-49° C/32-120° F and at a relative humidity of 85% RH (non-condensing) at 30° C/86° F. However, the useful life of the system's standby batteries and the electronic components may be adversely affected by extreme temperature ranges and humidity. Therefore, it is recommended that this system and its peripherals be installed in an environment with a nominal room temperature of 15-27° C/60-80° F.

Verify that wire sizes are adequate for all initiating and indicating device loops. Most devices cannot tolerate more than a 10% I.R. drop from the specified device voltage.

Like all solid state electronic devices, this system may operate erratically or can be damaged when subjected to lightning induced transients. Although no system is completely immune from lightning transients and interferences, proper grounding will reduce susceptibility. *Overhead or outside aerial wiring is not recommended, due to an increased susceptibility to nearby lightning strikes.* Consult with the Technical Services Department if any problems are anticipated or encountered.

Disconnect AC power and batteries prior to removing or inserting circuit boards. Failure to do so can damage circuits.

Remove all electronic assemblies prior to any drilling, filing, reaming, or punching of the enclosure. When possible, make all cable entries from the sides or rear. Before making modifications, verify that they will not interfere with battery, transformer, and printed circuit board location.

Do not tighten screw terminals more than 9 in-lbs. Over tightening may damage threads, resulting in reduced terminal contact pressure and difficulty with screw terminal removal.

This system contains static-sensitive components. Always ground yourself with a proper wrist strap before handling any circuits so that static charges are removed from the body. Use static suppressive packaging to protect electronic assemblies removed from the unit.

Follow the instructions in the installation, operating, and programming manuals. These instructions must be followed to avoid damage to the control panel and associated equipment. FACP operation and reliability depend upon proper installation.

Fire Alarm System Limitations

While installing a fire alarm system may make lower insurance rates possible, it is not a substitute for fire insurance!

An automatic fire alarm system - typically made up of smoke detectors, heat detectors, manual pull stations, audible warning devices, and a fire alarm control with remote notification capability can provide early warning of a developing fire. Such a system, however, does not assure protection against property damage or loss of life resulting from a fire.

Any fire alarm system may fail for a variety of reasons:

Smoke detectors may not sense fire where smoke cannot reach the detectors such as in chimneys, in walls, or roofs, or on the other side of closed doors. Smoke detectors also may not sense a fire on another level or floor of a building. A second floor detector, for example, may not sense a first floor or basement fire. Furthermore, all types of smoke detectors - both ionization and photoelectric types, have sensing limitations. No type of smoke detector can sense every kind of fire caused by carelessness and safety hazards like smoking in bed, violent explosions, escaping gas, improper storage of flammable materials, overloaded electrical circuits, children playing with matches, or arson.

IMPORTANT! *Smoke detectors must be installed in the same room as the control panel and in rooms used by the system for the connection of alarm transmission wiring, communications, signaling, and/or power.* If detectors are not so located, a developing fire may damage the alarm system, crippling its ability to report a fire.

Audible warning devices such as bells may not alert people if these devices are located on the other side of closed or partly open doors or are located on another floor of a building.

A fire alarm system will not operate without any electrical power. If AC power fails, the system will operate from standby batteries only for a specified time.

Rate-of-Rise heat detectors may be subject to reduced sensitivity over time. For this reason, the rate-of-rise feature of each detector should be tested at least once per year by a qualified fire protection specialist.

Equipment used in the system may not be technically compatible with the control. It is essential to use only equipment listed for service with your control panel.

Telephone lines needed to transmit alarm signals from a premise to a central monitoring station may be out of service or temporarily disabled.

The most common cause of fire alarm malfunctions, however, is inadequate maintenance. All devices and system wiring should be tested and maintained by professional fire alarm installers following written procedures supplied with each device. System inspection and testing should be scheduled monthly or as required by National and/or local fire codes. Adequate written records of all inspections should be kept.

Contents

| | |
|--|-----------|
| Section One: General Information | 4 |
| General | 4 |
| Features | 4 |
| Figure 1-1: Component Summary | 5 |
| SW1 DIP Switch Settings | 6 |
| Figure 1-2: SW1 DIP Switch Settings Example | 6 |
| Figure 1-3: SW2 DIP Switch Settings Example | 7 |
| Table 1-1: LED-10 Addressing | 8 |
| Figure 1-4: Typical Configuration | 8 |
| | |
| Section Two: Operation | 9 |
| Display Patterns | 9 |
| Switch Functions | 9 |
| Acknowledge/Step Switch | 9 |
| Silence Switch | 10 |
| Drill Switch | 11 |
| System Reset Switch | 11 |
| LED Indicators | 11 |
| | |
| Section Three: Mounting | 12 |
| Figure 3-1: LED-10 Hardware | 12 |
| Figure 3-2: LED-10 Mounting | 13 |
| | |
| Section Four: LED-10 Electrical Connections | 14 |
| Figure 4-1: Power Connection | 14 |
| Figure 4-2: LED-10IM Installation | 15 |
| Figure 4-3: EIA-485 Connection | 16 |
| Figure 4-4: Wiring FACP to LED-10 | 17 |
| | |
| Section Five: EIA-485 Shield Terminations | 18 |
| When the EIA-485 Shield is not in Conduit | 18 |
| When the EIA-485 Shield is in Full Conduit | 19 |
| | |
| Spare Slide-In Labels for LED-10 | 21 |

Section One: General Information

General

The Fire•Lite LED-10 is a compact, attractive LED-type fire annunciator designed for use with the MS-5210UD Fire Alarm Control Panel. *The MS-5210UD must have software P/N 73820 or higher to support the LED-10.*

The LED-10 is capable of displaying independent zone fire alarm, process monitor alarm, trouble or supervisory status. It also provides system status LEDs to display Power, Alarm, Trouble, Supervisory and Signals Silenced conditions. The LED-10 is also capable of performing system acknowledge, silence, drill and reset remotely.

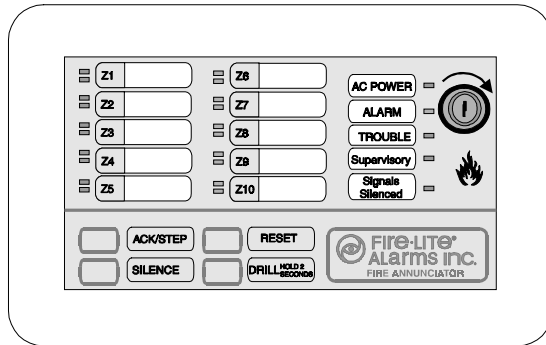

Communication between the control panel and the LED-10 is accomplished over a two-wire serial interface employing the EIA-485 communication standard. Up to 32 LED-10s may be connected to the two-wire EIA-485 circuit. The annunciator may be powered from the host FACP or remote, UL listed, filtered, regulated power supplies.

Features

- Alarm LEDs (red) and Trouble LEDs (yellow) for 10 zones.
- System Status LEDs for Power (green), Alarm (red), Trouble (yellow), Supervisory (yellow) and Signals Silenced (yellow).
- Local piezo sounder with alarm and trouble resound.
- Distinctly different flash rates for LEDs and piezo sounder distinguish system status:
 - ✓ fire alarm = 1 second on and 1 second off
 - ✓ process monitor alarm = 1/4 second on and 1/4 second off
 - ✓ supervisory alarm = 1/2 second on and 1/2 second off
- EIA-485 connects to control panel terminal port (requires LED-10IM module).
- Plug-in terminal blocks for ease of installation and service.
- Control buttons and enable key-switch for:
 - Acknowledge
 - Signal Silence
 - Drill
 - System Reset
- DIP switches control local functions such as piezo enable/disable, control switches, key-switch enable/disable and transmit/receive mode.
- Up to 32 LED-10s per MS-5210UD.
- Mounting options:
 - Surface or semi-flush mounting in standard three-gang electrical box
 - Can be located up to 6,000 feet from the panel using 18 AWG wire
- Slide-in labels for custom labeling.
- Simple programming at MS-5210UD panel enables communications to LED-10 annunciators.

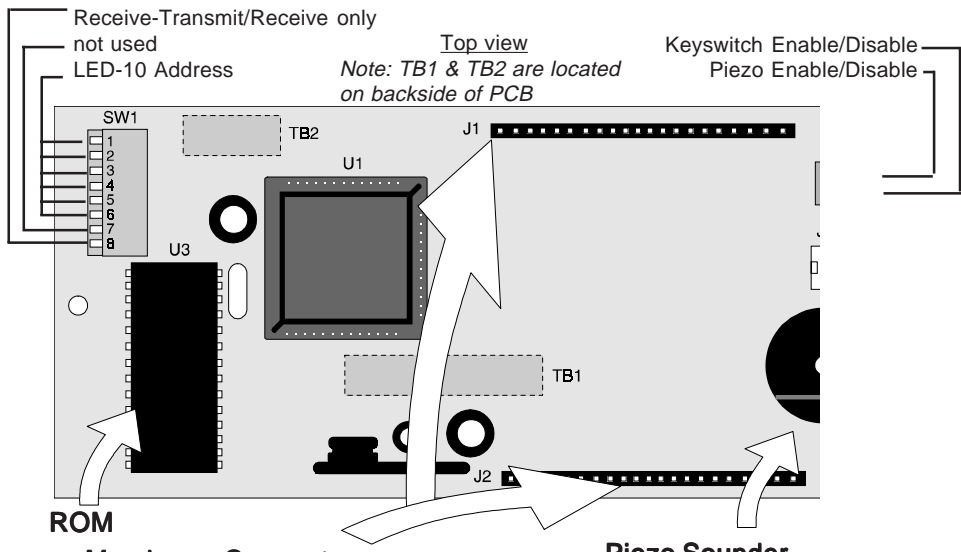

ROM

Membrane Connectors
Membrane switch connectors

Piezo Sounder

The LED-10 sounder, if enabled, will be activated when any new alarm or trouble is received from the panel. It is silenced by the ACKNOWLEDGE or SILENCE switch. Piezo must not be disabled without approval of LAHJ (Local Authority Having Jurisdiction).

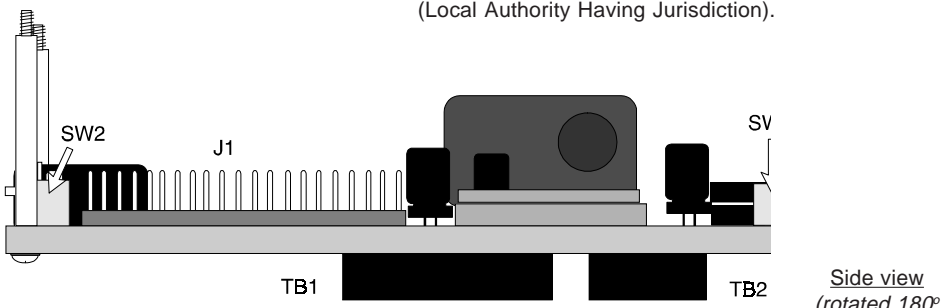

Side view
(rotated 180°
from above
[Top] view)

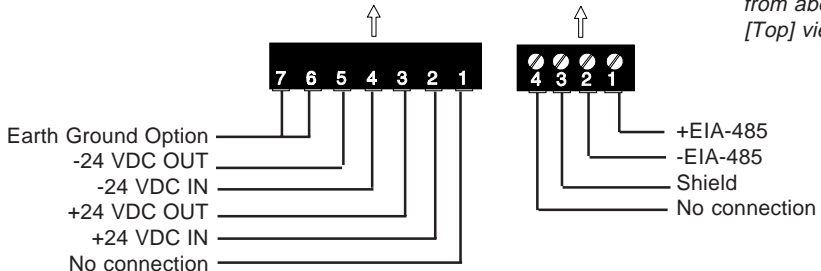

Note: These connections must be power-limited and the +24 volt power (18 VDC to 26 VDC) must be regulated and filtered.

| Current Consumption @ 24 VDC (Regulated and filtered) | |
|---|--|
| Normal/Standby (no activity): | 23 mA |
| Trouble Condition: | 31 mA |
| Alarm: | 28 mA (1 zone in alarm) 40 mA (all 10 zones in alarm) |
| AC Fail: | 24 mA |

Figure 1-1: Component Summary

SW1 DIP Switch Settings

The OPEN position on SW1 is the OFF state. Refer to Figure 1-2 for an explanation of DIP switch positions. SW1 switch settings are as follows:

1 through 6 - LED10 address switches.

The first six switches are used to set the address of the LED-10. The OFF (OPEN) up position equals a binary 1 and the ON down position equals a binary 0. Refer to Table 1-1 for information on setting these switches for specific addresses. Each LED-10 connected to the EIA-485 communication bus must have a unique address.

7 - Not used

8 - ON = Receive/Transmit, OFF (OPEN) = Receive Only

Switch 8 set to ON position enables Receive/Transmit mode for the LED-10 annunciator. This allows the LED-10 to receive and display system status information and to transmit system control data such as Acknowledge/Step, Reset, Signal Silence and Drill. Switch 8 set to the OFF position enables Receive Only mode which allows the LED-10 to receive and display system status information but prevents control button operation and supervision status from being transmitted back to the FACP. To ensure LED-10 supervision and control button capability, each LED-10 connected to the EIA-485 communication bus must have a unique address and should be set to enable Receive/Transmit Mode.

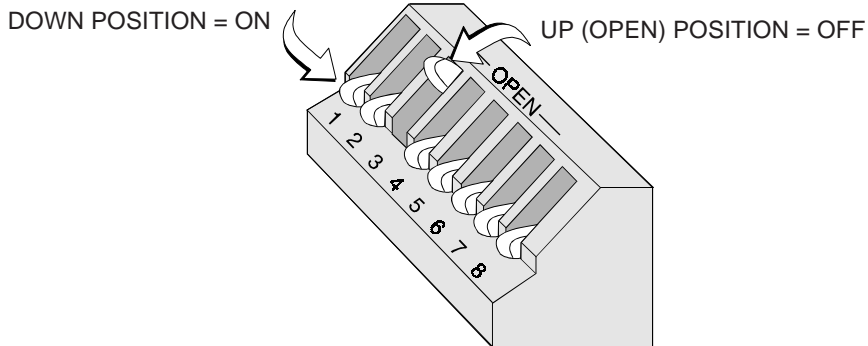

NOTE - SW1 DIP switch settings as illustrated in Figure 1-2 are as follows:

- 1) DIP switches 1 - 6: Address 08 (see Table 1-1).
- 2) DIP switch 7: Not used.
- 3) DIP switch 8: ON = Receive/Transmit

Figure 1-2: SW1 DIP Switch Settings Example

SW2 DIP Switch Settings

SW2 switch settings are as follows:

- 1 - ON = Key-switch Enable, OFF = Key-switch Disable.
 Switch 1 set to the ON position enables the key-switch operation. The key-switch may now be used to enable LED-10 membrane (control) switches, allowing remote switch functions, or lockout the switches, preventing remote switch functions. Switch 1 set to the OFF position disables the key-switch operation. Refer to Operation Section for key-switch function description.
- 2 - ON = Piezo sounder enabled, OFF = Piezo sounder disabled.
CAUTION: Piezo sounder must not be disabled without prior approval of the Local Authority Having Jurisdiction.

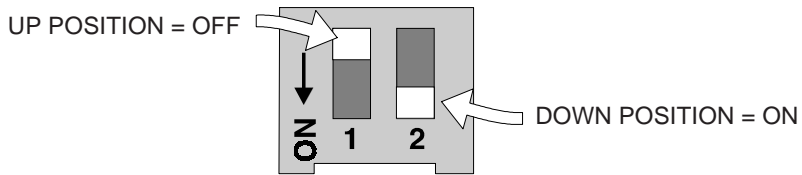

Figure 1-3: SW2 DIP Switch Settings Example

LED-10 Addressing

SW1 DIP switches 1 through 6 are used for addressing the LED-10. *Each device connected to the EIA-485 communication bus **must** have a unique address.* This allows specific data to be transmitted between the FACP and that device and for individual supervision of each LED-10 annunciator by the FACP. Switch settings and the corresponding addresses are shown in Table 1-1. (Address '00' is invalid).

Note: 1 = Switch in the UP (OPEN) position.
 0 = Switch in the DOWN position.

Example:

| ADDRESS | SWITCH SETTINGS | | | | | |
|---------|-----------------|---|---|---|---|---|
| | 1 | 2 | 3 | 4 | 5 | 6 |
| 08 | 0 | 0 | 1 | 0 | 0 | 0 |

Addressing Switches

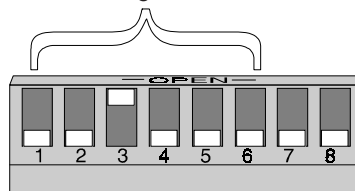

| ADDRESS | SWITCH SETTINGS | | | | | | ADDRESS | SWITCH | | |
|---------|-----------------|---|---|---|---|---|---------|--------|---|---|
| | 1 | 2 | 3 | 4 | 5 | 6 | | 1 | 2 | 3 |
| INVALID | 0 | 0 | 0 | 0 | 0 | 0 | 17 | 0 | 1 | 0 |
| 01 | 0 | 0 | 0 | 0 | 0 | 1 | 18 | 0 | 1 | 0 |
| 02 | 0 | 0 | 0 | 0 | 1 | 0 | 19 | 0 | 1 | 0 |
| 03 | 0 | 0 | 0 | 0 | 1 | 1 | 20 | 0 | 1 | 0 |
| 04 | 0 | 0 | 0 | 1 | 0 | 0 | 21 | 0 | 1 | 0 |
| 05 | 0 | 0 | 0 | 1 | 0 | 1 | 22 | 0 | 1 | 0 |
| 06 | 0 | 0 | 0 | 1 | 1 | 0 | 23 | 0 | 1 | 0 |
| 07 | 0 | 0 | 0 | 1 | 1 | 1 | 24 | 0 | 1 | 1 |
| 08 | 0 | 0 | 1 | 0 | 0 | 0 | 25 | 0 | 1 | 1 |
| 09 | 0 | 0 | 1 | 0 | 0 | 1 | 26 | 0 | 1 | 1 |
| 10 | 0 | 0 | 1 | 0 | 1 | 0 | 27 | 0 | 1 | 1 |
| 11 | 0 | 0 | 1 | 0 | 1 | 1 | 28 | 0 | 1 | 1 |
| 12 | 0 | 0 | 1 | 1 | 0 | 0 | 29 | 0 | 1 | 1 |
| 13 | 0 | 0 | 1 | 1 | 0 | 1 | 30 | 0 | 1 | 1 |
| 14 | 0 | 0 | 1 | 1 | 1 | 0 | 31 | 0 | 1 | 1 |
| 15 | 0 | 0 | 1 | 1 | 1 | 1 | 32 | 1 | 0 | 0 |
| 16 | 0 | 1 | 0 | 0 | 0 | 0 | | | | |

Table 1-1: LED-10 Addressing

Typical Configuration

The LED-10 indicates the status of the MS-5210UD, while offering multiple annunciator locations with the capability of remote Acknowledge, Signal Silence, Drill and Reset functions. The LED-10 displays zone status and requires no programming.

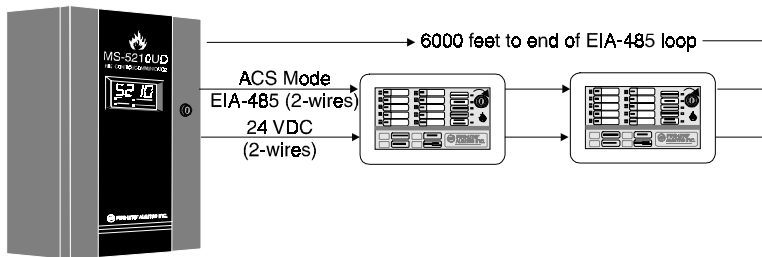

NOTES:

- 1) **EIA-485:** Maximum of 6,000 feet total cable length from FACP to LED-10s. Circuit is power-limited.
- 2) Up to 32 LED-10s may be used on the EIA-485 circuit. The MS-5210UD can power a maximum of seven LED-10s. If additional LED-10s are connected, the Fire•Lite FCPS-24F may be used to supply additional power. (Power supplies used for this purpose must have their negative terminals commoned together).
- 3) Between each LED-10 are four wires: A twisted-shielded pair for data communications and a pair for 24 VDC power.

Figure 1-4: Typical Configuration

Section Two: Operation

LED Indicators and Piezo Sounder

The LED-10 is an LED annunciator which indicates the system and zone status of its associated MS-5210UD fire alarm control panel.

AC Power

This is a green LED which illuminates if AC power is applied to the host FACP. The green LED will turn off if AC power to the host FACP is lost.

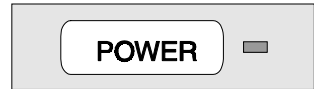

Alarm

This is a red LED that flashes (1 second on, 1 second off) when one or more fire alarms occur. The piezo sounder turns on steady for alarm. The LED illuminates steadily when the Acknowledge or Silence key is pressed and the piezo silences. The Alarm LED turns off when the Reset key is pressed.



Trouble

This is a yellow LED that flashes (1 second on, 1 second off) when one or more trouble conditions occur. The piezo sounder pulses (1 second on, 1 second off). The LED turns on steady when the Acknowledge or Silence key is pressed and the piezo silences. The LED turns off when all trouble conditions are cleared. This LED will also illuminate if the microprocessor watchdog circuit within the LED-10 is activated.

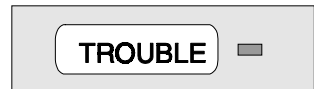

Supervisory

This is a yellow LED that flashes (1/2 second on, 1/2 second off) when one or more supervisory conditions occur, such as a sprinkler valve tamper condition. The piezo sounder pulses (1/2 second on, 1/2 second off). The LED illuminates steadily when the Acknowledge or Silence key is pressed and the piezo silences. The Supervisory LED turns off when the Reset key is pressed.



Zone Alarm - Zones 1 through 10

This is a red LED that flashes when a fire alarm, supervisory alarm or process monitoring alarm occurs on the corresponding zone. The LED flashes at a 1 second on/1 second off rate for an alarm condition, a 1/2 second on/1/2 second off rate for a supervisory alarm and a 1/4 second on/1/4 second off rate for a process monitoring alarm. The piezo sounder will pulse at a rate corresponding to the flashing LED. The LED illuminates steadily when the Acknowledge or Silence key is pressed and the piezo silences. The LED turns off when the alarm, process monitoring alarm or supervisory alarm is cleared on the corresponding zone and the Reset key is pressed.

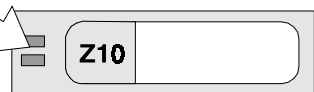

Note: Be certain to use customized slide-in label to identify the zone function. This red LED will flash for supervisory conditions if the FACP is not programmed for Canadian operation. Refer to the MS-5210UD Manual P/N 50193 for details.

Zone Trouble/Supervisory - Zones 1 through 10

This is a yellow LED that flashes when a supervisory alarm or zone trouble condition occurs on the corresponding zone. The LED flashes at a 1/2 second on/1/2 second off rate along with the red zone LED above it for a zone supervisory alarm.

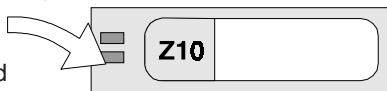

The LED flashes at a 1 second on/1 second off rate for a zone trouble condition.

The piezo sounder will pulse at a rate corresponding to the flashing LED. The LED illuminates steadily when the Acknowledge or Silence key is pressed and the piezo silences. The LED turns off when all trouble conditions on the corresponding zone are cleared. The LED turns off when all supervisory alarms on the corresponding zone are cleared and the Reset key is pressed.

Note: When the MS-5210UD is programmed for Canadian supervisory annunciation, only the yellow LED flashes for a supervisory alarm condition. The red LED above it remains off. Refer to the MS-5210UD Manual P/N 50193.

Switch Functions

Key-switch

The key-switch is used to enable and disable the operation of the membrane (control) switches if switch 1 on DIP switch SW2 has been placed to the ON position.

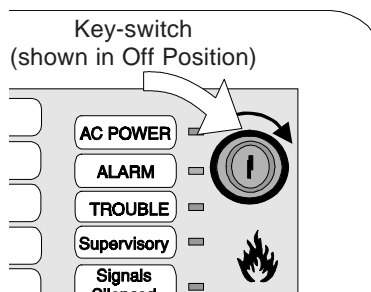

To enable the Acknowledge, Silence, Drill and Reset function keys, insert a standard Fire•Lite key into the key-switch located at the top right corner of the LED-10. Make certain the key is inserted completely before attempting to turn it. Turn the key clockwise until it stops. Leave the key inserted while pressing the function key(s). When finished with the function keys, turn key-switch counterclockwise to disable function keys.

Note: The key-switch should normally be in the disabled position (fully counterclockwise), with the key removed and access to the key restricted to authorized personnel only. Do not leave the key unattended in the LED-10.

Acknowledge

When the Acknowledge key is pressed and released, the LED-10 sends an Acknowledge command to the control panel. Pressing the Acknowledge key silences the local piezo sounder, the sounders located in all other system annunciators and the sounder located on the Fire Alarm Control Panel's main circuit board. It will also change all flashing system LEDs to steady on. Only one press is necessary regardless of the number of new alarms, troubles or supervisory signals. An acknowledge message is also sent to the printer and the history files in the MS-5210UD.



Silence

When the Silence key is pressed and released, the LED-10 sends a Signal Silence command to the control panel. The Silence key performs the same functions as the Acknowledge key. In addition, if an alarm exists, it turns off all *silenceable* NAC outputs only and causes the FACP ALARM SILENCE LED and the LED-10 SIGNAL SILENCE LED to turn on. It also sends an ALARM SILENCED message to the printer and the history file within the MS-5210UD. A subsequent new alarm will resound the appropriate Notification Appliance Circuits (NACs) and local sounders.



Drill: Hold 2 Sec.

When the Drill key is pressed and held for at least two seconds (time required to prevent accidental activations), the LED-10 will transmit a drill command to the control panel. This command causes the FACP to turn on all main panel NAC outputs. In the event that the system was previously silenced, the drill command will also turn off the ALARM SILENCE LED. (The Silence key operates on *silenceable* NAC outputs only).



Reset

When the System Reset key is pressed and released, the LED-10 sends a Reset command to the control panel. This will turn off all Notification Appliance Circuits, temporarily turns off resettable power to 4-wire detectors, and sends a "SYSTEM RESET" message to the FACP display, printer and MS-5210UD history files. It also turns on all system LEDs, piezo sounders and FACP LED display segments as long as the Reset key is held (lamp test). Any alarm or trouble that exists after a Reset will resound the system.



Section Three: Mounting

LED-10 Preparation

The LED-10 can be surface or semi-flush mounted **ONLY** in a three-gang electrical box, Fire•Lite P/N 10103 or equivalent, with a minimum depth of 2.5". Select and remove the appropriate knockout(s), pull the necessary wires through the knockouts and mount the three-gang box in or on the wall depending on the type of installation desired. *Be certain that power is not applied to the wiring during the installation procedure.*

Note: To ensure static protection, all enclosures, including the LED-10 electrical box, must be connected to earth ground! Never use the shield of the communications wiring for static protection.

To mount the LED-10 in the electrical box, the trim ring must first be removed. The trim ring is held in place by two screws inserted through the top and bottom edge as illustrated above. Removal of the trim ring will expose a metal flange with mounting holes.

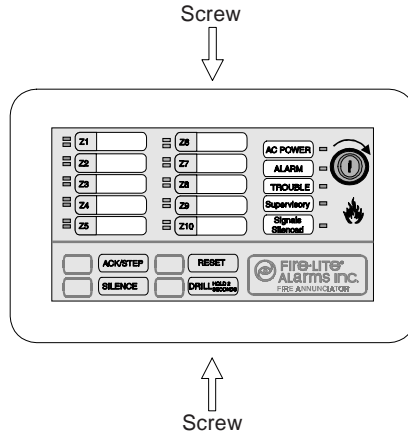

Mounting

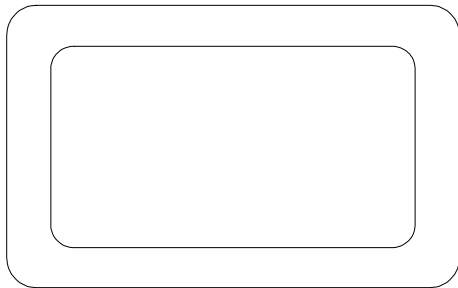

LED-10 Trim ring

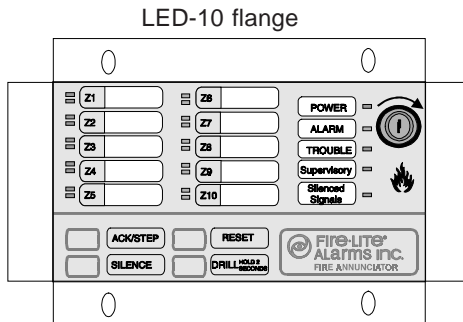

Figure 3-1: LED-10 Hardware

Mounting to Backbox

Remove the plug-in terminal blocks from the LED-10 circuit board. Connect the EIA-485 and power wiring into the terminal block positions illustrated in Figures 1-1, 4-1 and 4-2. Plug the terminal blocks back into the TB1 and TB2 connectors on the back of the LED-10.

Set DIP switches SW1 and SW2 for the desired options (refer to Figures 1-1 and 1-2 and Table 1-1).

Mount the LED-10 to the three-gang electrical box using the four mounting holes on the LED-10 flange and the four screws provided for this purpose. Replace the trim ring and secure with the two screws which were previously removed. Adjust the plastic trim ring to the surface of the wall before tightening the screws. *Do not overtighten.*

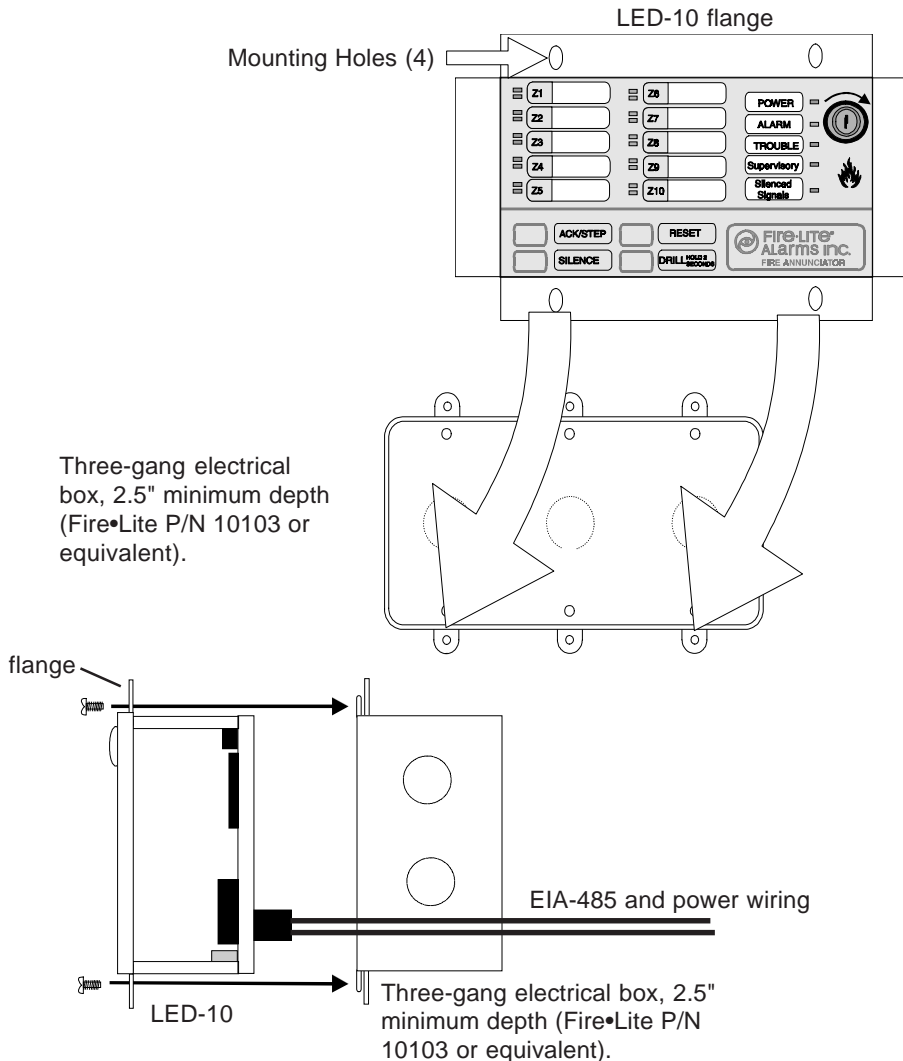
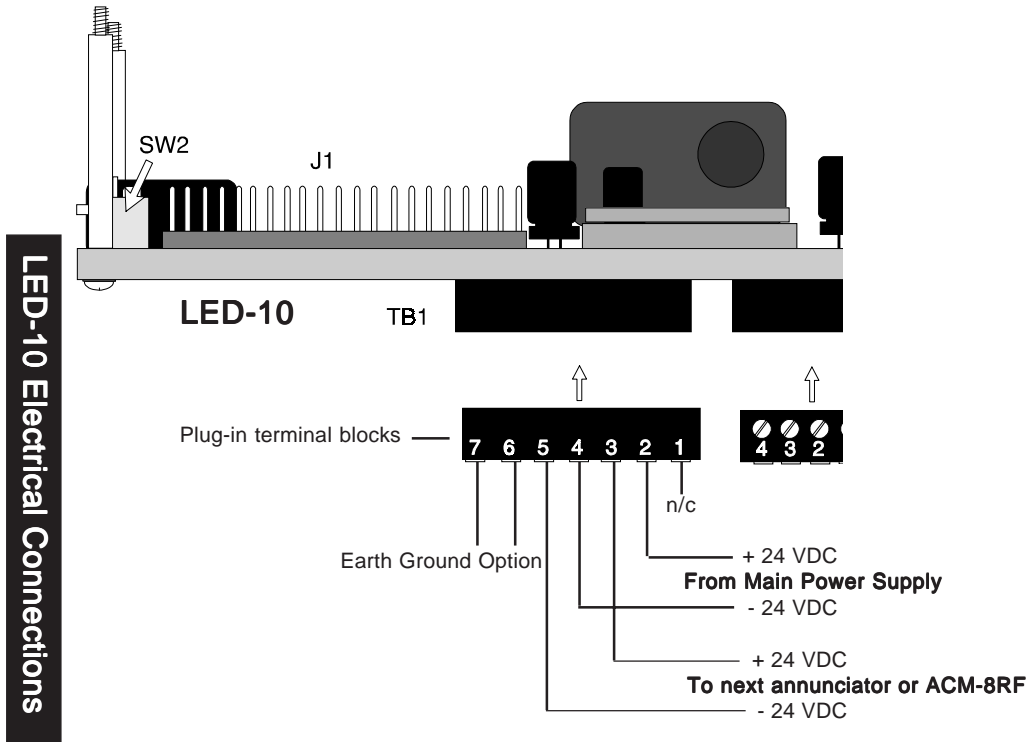

Figure 3-2: LED-10 Mounting

Section Four: LED-10 Electrical Connections

The LED-10 can be powered by the MS-5210UD regulated power output or from a remote, UL listed, filtered, regulated power supply such as the Fire•Lite FCPS-24F. The power run to the LED-10 must be power-limited but need not contain a power supervision relay since loss of power is inherently supervised through loss of communication with the LED-10. Maximum LED-10 current draw from the power supply under alarm condition is 28 mA. Maximum current draw from the control panel's secondary power source (batteries) under loss of AC power is 24 mA.



Note: All connections are power-limited and supervised.

Figure 4-1: Power Connection

LED-10IM

The LED-10IM Interface Module provides an EIA-485 port to support the LED-10, AFM Series and LDM Series annunciators as well as the ACM-8RF Remote Relay Module and is therefore required when connecting these devices to the MS-5210UD. The MS-5210UD supervises EIA-485 wiring for open circuits via the LED-10IM Interface Module. The LED-10IM plugs into connector J6 located in the upper right corner of the MS-5210UD main circuit board.

Install the two supplied standoffs into the FACP main circuit board. Ensure that the metal standoff is installed in the position indicated in the illustration below. Carefully align the two connectors and press the LED-10IM module securely into place. Make certain the pins are properly aligned to prevent bending or breaking of any pins. It is important that the supplied screw and washer be used to secure the module to the metal standoff. This is necessary in order to help protect against electrical transients.

Note: Refer to the MS-5210UD Manual Programming Section for information on programming the LED-10 into the system.

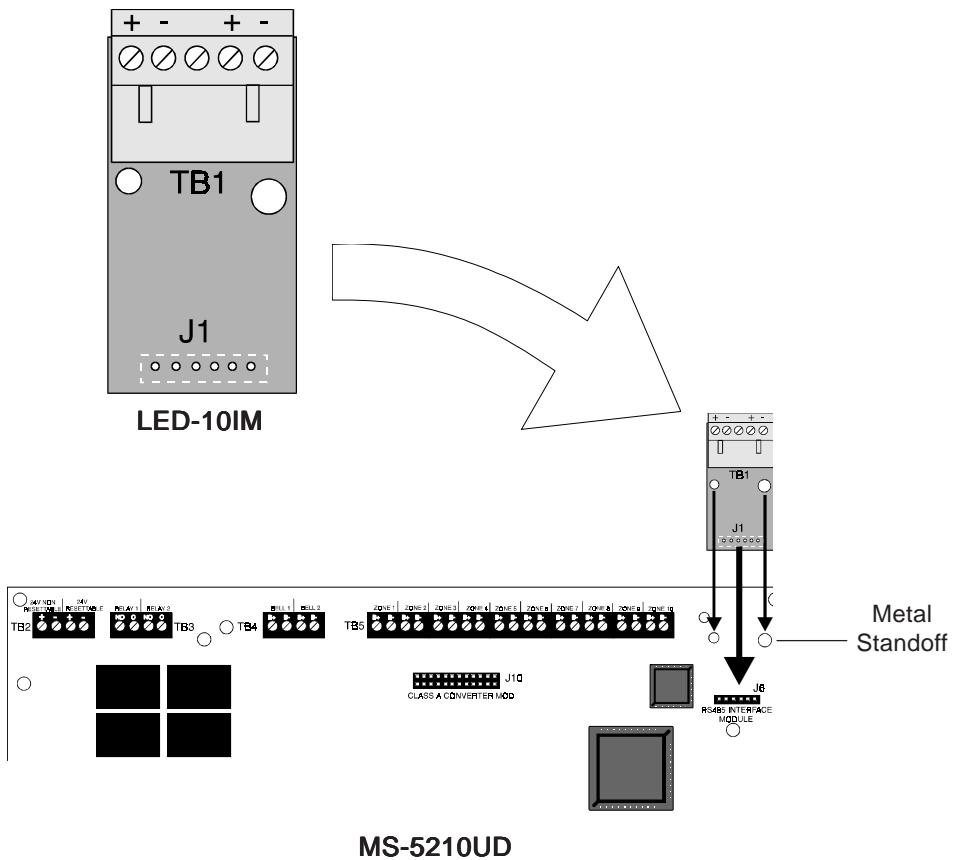
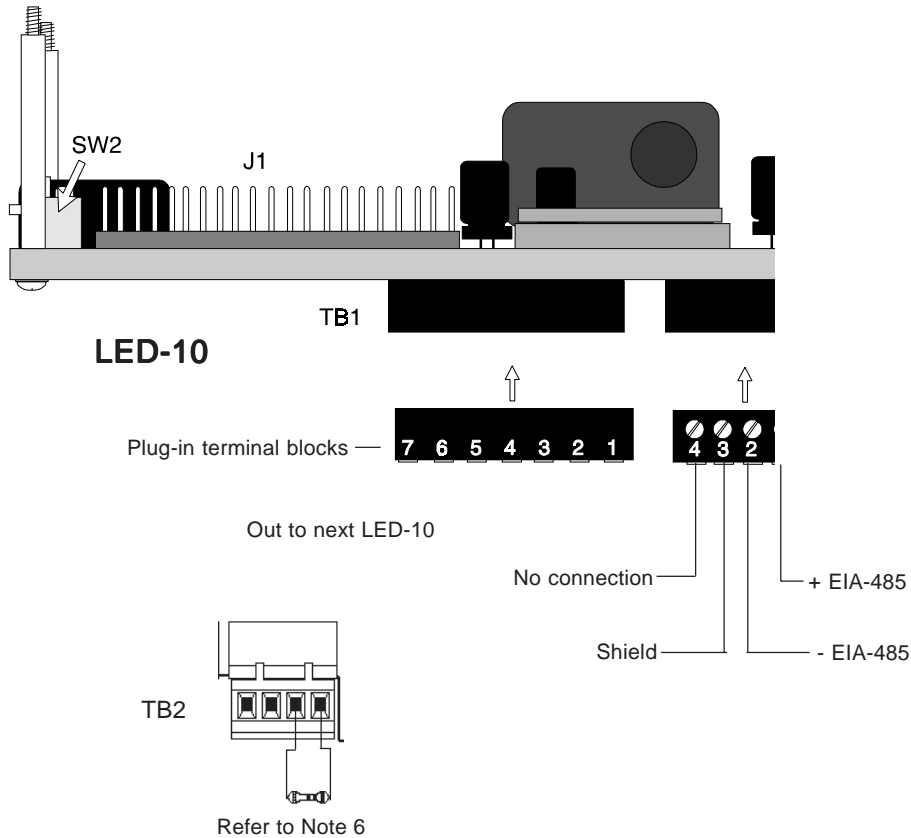

Figure 4-2: LED-10IM Installation



LED-10 Electrical Connections

Notes:

- 1) All connections are power-limited and supervised.
- 2) A maximum of 32 LED-10s may be connected to this circuit.
- 3) 6,000 feet maximum distance (@ 18 AWG) between the panel and LED-10(s).
- 4) Use overall foil/braided-shield twisted pair cable suitable for EIA-485 applications (refer to Section Five for shield termination information).
- 5) The EIA-485 circuit is rated at 5.5 VDC maximum and 60 mA maximum.
- 6) The LED-10 must have the supplied R120 (120 ohm) resistor installed across the EIA-485 terminals on the last or only device connected to the EIA-485 bus as shown. The resistor is required for impedance matching.

Figure 4-3: EIA-485 Connection

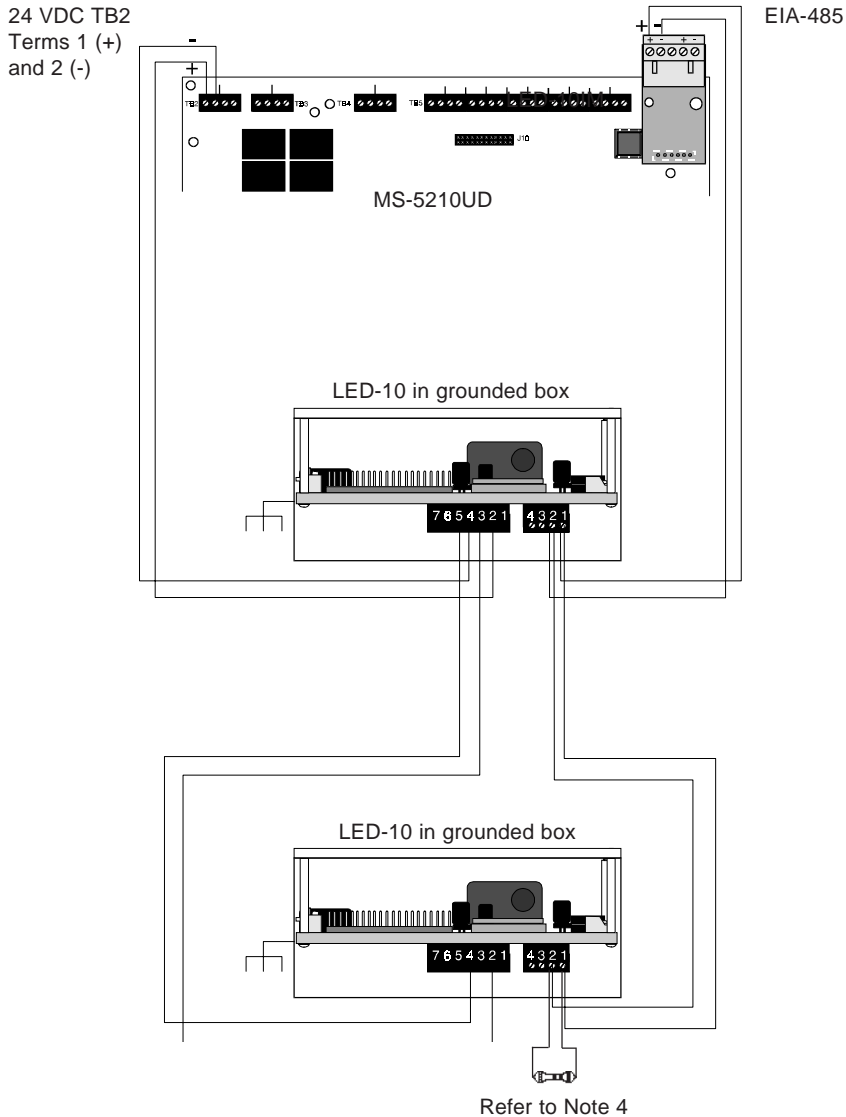

CAUTION! Please be certain to secure the LED-10IM module to the MS-5210UD and to keep all wiring from mechanically interfering with the LED-10IM.

Note:

- 1) Twisted, shielded wire is recommended for the EIA-485 communications loop.
- 2) Four-conductor, overall shielded wire may be used for the four EIA-485 wires and the two power wires. It is, however, strongly recommended that the power and communication wires be separate whenever possible.
- 3) Refer to Figures 4-2, 4-2 and 4-3 for LED-10 and LED-10IM terminal designations.
- 4) The LED-10 must have the supplied R120 (120 ohm) resistor installed across the EIA-485 terminals on the last or only device connected to the EIA-485 bus as shown. The resistor is required for impedance matching.

Figure 4-4: Wiring FACP to LED-10

Section Five: EIA-485 Shield Terminations

The EIA-485 circuit must be wired using a twisted-shielded pair cable having a characteristic impedance of 120 ohms, +/- 20%. Do not run cable adjacent to, or in the same conduit as, 120-volt AC service, noisy electrical circuits that are powering mechanical bells or horns, audio circuits above 25 V_{RMS}, motor control circuits, or SCR power circuits

Note: To ensure static (ESD - electrostatic discharge) protection, all enclosures, including the LED-10 electrical box, must be connected to earth ground! Never use the EIA-485 shield for this purpose. The EIA-485 shield is for radiated noise emission protection (RFI, EMI). Refer to the following figures.

The EIA-485 shield should be terminated as follows:

When the EIA-485 shield is not in conduit: The EIA-485 loop allows the FACP to communicate with the LED-10(s). The shield for the EIA-485 loop must be connected to earth ground at the FACP but must be left floating (no connection) at the LED-10 if it is the first or only device on the EIA-485 loop. If a second LED-10 is connected, the shield leaving the first LED-10 must be left floating. The shield entering the second LED-10 must be connected to the 3-gang box or Earth Ground terminal (TB1-6 & 7) on the second LED-10. If additional LED-10s are connected, the shield leaving each enclosure must be left floating and the shield entering each must be connected to the 3-gang box or the Earth Ground Terminal (TB1-6 & 7) on the LED-10.

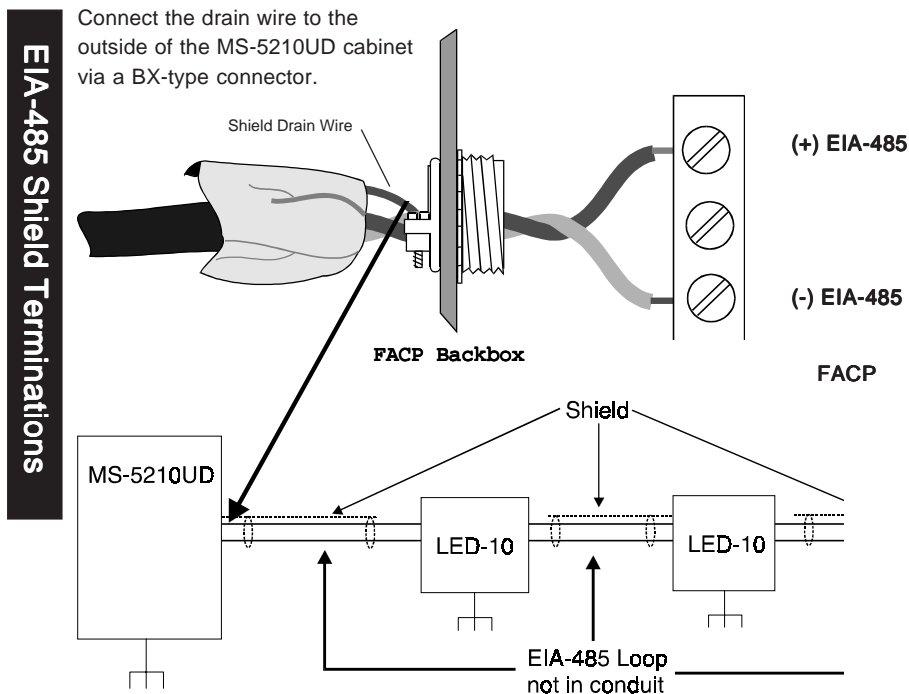

When the EIA-485 shield is in full conduit: The EIA-485 loop allows the FACP to communicate with the LED-10(s). The shield for the EIA-485 loop must be connected to earth ground at the FACP, but must be left floating (no connection) at the LED-10 if it is the first or only device on the EIA-485 loop. If a second LED-10 is connected, the shield leaving the first LED-10 must be left floating. The shield entering the second LED-10 must be connected to the Earth Ground Terminal (TB1- 6 & 7) on the second LED-10. If additional LED-10s are connected, the shield leaving each LED-10 must be left floating and the shield entering the following unit must be connected to the Earth Ground Terminal (TB1 - 6 & 7) on the LED-10.

Caution! Do not allow the floating (no connection) end of the shield to contact the conduit. The floating end should be insulated from earth ground.

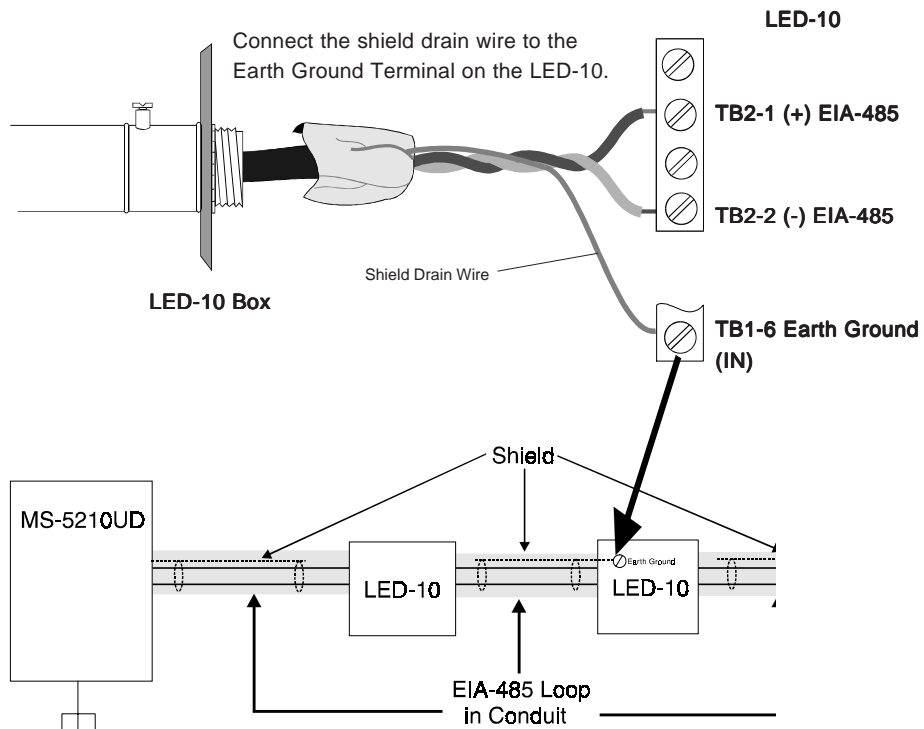

Notes:

- 1) Power-limited 24 VDC regulated power may be run in the same conduit as the EIA-485 wiring.
- 2) Twisted, shielded wire is recommended for the EIA-485 communications loop.
- 3) Each LED-10 electrical backbox is connected to earth ground via the conduit.
- 4) Shield is connected to the FACP cabinet (earth ground) leaving the FACP.

Notes

Slide-In Labels for the LED-10

Slide-in labels for Zones 1 -10 are included with the LED-10(s). In the event that these labels are damaged or lost, remove this page from the manual and type the appropriate information on the labels shown below. Type on the lines provided to ensure centering of information in label windows. Carefully cut out the labels and insert them into the two label slots on the top left side of the LED-10 annunciator face plate.

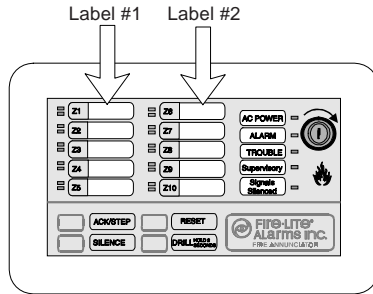

Note: To ensure the best fit, cut directly along the dotted line surrounding each label.

| Custom User Label #1 | Custom User Label #2 |
|-------------------------|-------------------------|
| | |
| | |
| | |
| | |
| | |
| | |

| Custom User Label #1 | Custom User Label #2 |
|-------------------------|-------------------------|
| | |
| | |
| | |
| | |
| | |
| | |
| | |

Limited Warranty

Fire-Lite® warrants its products to be free from defects in materials and workmanship for eighteen (18) months from the date of manufacture, under normal use and service. Products are date stamped at time of manufacture. The sole and exclusive obligation of **Fire-Lite®** is to repair or replace, at its option, free of charge for parts and labor, any part which is defective in materials or workmanship under normal use and service. For products not under **Fire-Lite®** manufacturing date-stamp control, the warranty is eighteen (18) months from date of original purchase by **Fire-Lite®**'s distributor unless the installation instructions or catalog sets forth a shorter period, in which case the shorter period shall apply. This warranty is void if the product is altered, repaired or serviced by anyone other than **Fire-Lite®** or its authorized distributors or if there is a failure to maintain the products and systems in which they operate in a proper and workable manner. In case of defect, secure a Return Material Authorization form from our customer service department. Return product, transportation prepaid, to **Fire-Lite®**, 12 Clintonville Road, Northford, Connecticut 06472-1653.

This writing constitutes the only warranty made by **Fire-Lite®** with respect to its products. **Fire-Lite®** does not represent that its products will prevent any loss by fire or otherwise, or that its products will in all cases provide the protection for which they are installed or intended. Buyer acknowledges that **Fire-Lite®** is not an insurer and assumes no risk for loss or damages or the cost of any inconvenience, transportation, damage, misuse, abuse, accident or similar incident.

Fire-Lite® GIVES NO WARRANTY, EXPRESSED OR IMPLIED, OF MERCHANTABILITY, FITNESS FOR ANY PARTICULAR PURPOSE, OR OTHERWISE WHICH EXTEND BEYOND THE DESCRIPTION ON THE FACE HEREOF. UNDER NO CIRCUMSTANCES SHALL **Fire-Lite®** BE LIABLE FOR ANY LOSS OF OR DAMAGE TO PROPERTY, DIRECT, INCIDENTAL OR CONSEQUENTIAL, ARISING OUT OF THE USE OF, OR INABILITY TO USE **Fire-Lite®** PRODUCTS. FURTHERMORE, **Fire-Lite®** SHALL NOT BE LIABLE FOR ANY PERSONAL INJURY OR DEATH WHICH MAY ARISE IN THE COURSE OF, OR AS A RESULT OF, PERSONAL, COMMERCIAL OR INDUSTRIAL USE OF ITS PRODUCTS.

This warranty replaces all previous warranties and is the only warranty made by **Fire-Lite®**. No increase or alteration, written or verbal, of the obligation of this warranty is authorized.

"**Fire-Lite**" is a registered trademark.



Fire-LITE® ALARMS
INCORPORATED

12 Clintonville Road,
Northford, CT 06472
Phone: (203) 484-7161
FAX: (203) 484-7118