

739 X-10 Interface Module

Description

The 739 X-10 Interface Module provides an interface between X-10 devices and DMP XR200, XR200-485, and XR2400F Command Processor™ Panels. The 739 Module allows the LX-Bus outputs of the panel to control the on/off status of the X-10 devices.

The 739 connects to the DMP LX-Bus using the standard 4-wire LX-Bus connector and does not require any address programming. Using the supplied RJ11 telephone cable, the 739 X-10 Interface Module easily connects to an X-10 Powerline Interface Module or X-10 Two-Way Powerline Interface Module to provide the on/off X-10 output commands. Refer to the back page for model numbers.

For example, if the 739 is on LX-Bus 2 and is controlling House Code A devices, when output 201 is turned on, the X-10 device set to A1 will turn on. If the X-10 device addressed as A1 is a lamp, when output 201 is on, the lamp is on.

Setting the House Code Jumpers

Each 739 Module can control up to 96 X-10 devices. You can install a second 739 Module on another LX-Bus circuit to control an additional 96 devices. One 739 Module is allowed per LX-Bus circuit.

Set JP1 according to the House Code group you wish to control. You may control devices with House Codes A through F or House Codes G through L.

The 739 Module can be connected to either LX-Bus and can control either group of House Codes. For example, you can install the 739 on LX-Bus 1 to have LX-Bus outputs 101 through 196 control House Codes A through F. You could then install a second 739 Module on LX-Bus 2 to use Outputs 201 through 296 control House Codes G through L.

See Table 1 for a list of the House Codes the LX-Bus outputs control. Refer to Tables 4 and 5 for exact conversions for each House Code device.

Set jumper JP1 according to the House Codes, or groups of X-10 devices, that you wish to control with the 739 Module. To control X-10 devices with House Codes A through F, place the jumper on the two pins of JP1 labeled 0 (zero). To control X-10 devices with House Codes G through L, place the jumper on the two pins of JP1 labeled 1 (one). Always leave JP2 on the two pins labeled 0 (zero).

House Code	X-10 Device	LX-Bus Output
A	A1 to A16	1 to 16
B	B1 to B16	17 to 32
C	C1 to C16	33 to 48
D	D1 to D16	49 to 64
E	E1 to E16	65 to 80
F	F1 to F16	81 to 96
G	G1 to G16	1 to 16
H	H1 to H16	17 to 32
I	I1 to I16	33 to 48
J	J1 to J16	49 to 64
K	K1 to K16	65 to 80
L	L1 to L16	81 to 96

Table 1: House Code Output Assignments

House Code	Group A (JP1)	Group B (JP2)
A - F	0	0
G - L	1	0

Table 2: House Code Jumper Settings

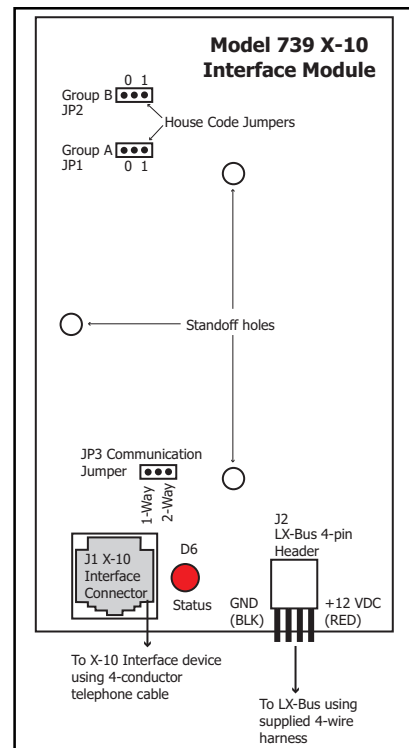

Figure 1: 739 Module PCB

Setting the Communication Jumpers

Set the communication jumper, JP3, according to the type of X-10 Powerline Interface Module to which the 739 Module will be connected. A One-Way Powerline Interface Module, such as an X-10 PSC04 or RadioShack® PL513, does not listen for other X-10 traffic on the house circuits and transmits its commands at any time. A Two-Way Powerline Interface Module, such as an X-10 PSC05 or RadioShack® TW523, listens for other X-10 traffic on the house circuits and transmits its commands when other X-10 devices are not transmitting.

If the interface module is a 1-Way communicator, install the jumper header on the two pins on J3 labeled 1-WAY. If the interface module operates in 2-way communication, install the jumper header on the two pins on J3 labeled 2-WAY.

RJ Cable Specifications

The RJ cable used between the X-10 Powerline Interface Module and the 739 is a straight, 4-conductor modular RJ11 cord, which is supplied with the 739 Module. This is also referred to as a Telephony Standard 4-Conductor Modular Cord. The pins on the connectors crossover as shown in Table 3.

739 Connector Pins		X-10 Module Pins
1	=	4
2	=	3
3	=	2
4	=	1

Table 3: Cable Pinouts

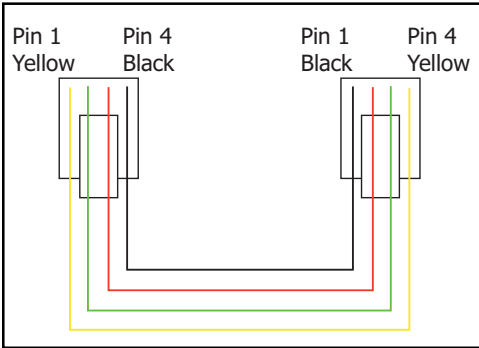

Figure 2: RJ11 Cable

Mounting in Enclosures

You can mount the 739 in a Model 349 Enclosure, 350 Enclosure, or the XR2400F enclosure, using the standard 3-hole mounting configuration.

1. Mount the plastic standoffs to the enclosure using the three included Phillips head screws.
2. Insert the screws from the outside of the enclosure through the holes and into the plastic standoff that mounts on the inside of the enclosure.
3. After the standoffs have been tightened and secured onto the enclosure, snap the 739 onto the standoffs.

Wiring the 739 Module

After properly mounting the 739, connect the supplied 4-wire harness to the 4-pin header, J2, on the 739 Module. Connect the 4 wires from the harness to the LX-Bus: Connect the red wire from the 739 to the red wire on the LX-Bus, yellow to yellow, green to green, and black to black.

Finally, connect a standard 4-conductor modular RJ11 cable to J1, X-10 Interface Connector, on the 739 Module to the telephone connector on the X-10 Powerline Interface Module. Refer to Figures 1 and 3.

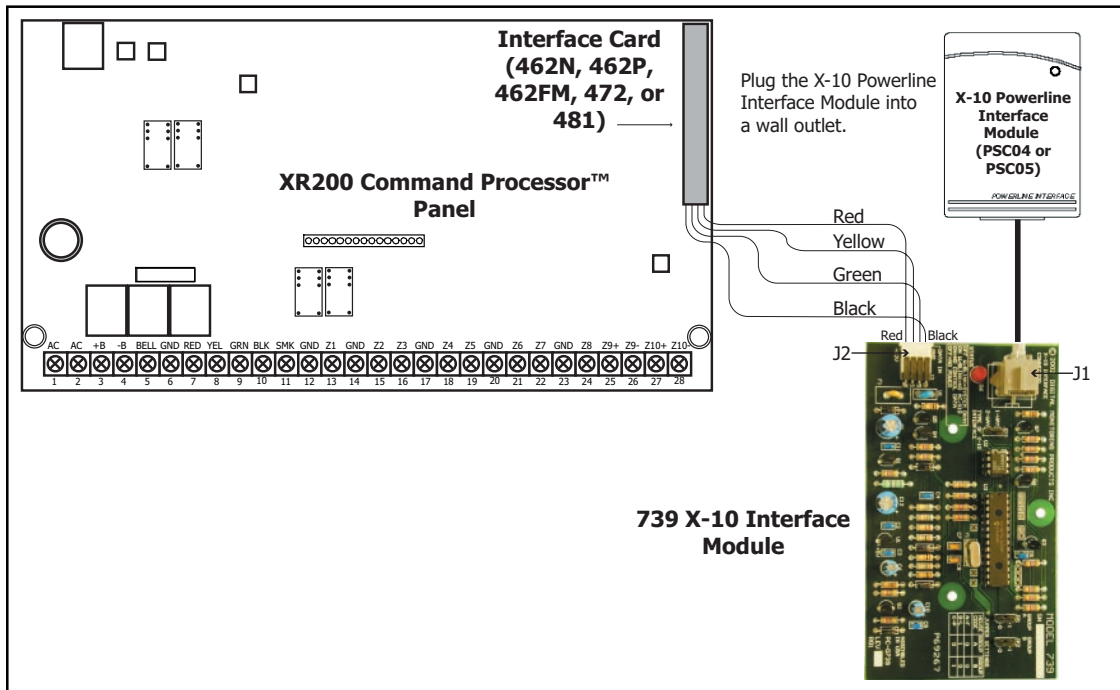

Figure 3: 739 Wiring Diagram

Checking the Status of the 739

The red LED (D6) on the 739 indicates system status.

Off with Blink: The 739 is operating normally and the system is okay.

On with Blink: The entire X-10 system is not receiving power

On: Indicates the 739 is not receiving data from the Command Processor™ panel.

Off: Indicates the 739 is not receiving power.

Special Output Commands

Outputs 100/200, 197/297, and 198/298 can be used to send special commands from the Panel to X-10 devices.

All Units Off

The All Units Off command allows users to turn off all X-10 devices controlled by the 739. Output 100/200 turns **All Units Off** with either an On or Off command that is a change from the last stored output state. For example, if output 100 is stored in the 739 in the ON state, the **All Units Off** command will turn output 100 OFF. To reset the units (lights) after the **Flash Mode** has occurred, program output 100/200 as the Sensor Reset output and then perform a Sensor Reset.

All Lights On

Output 197/297 turns **All Lights On**. An example of an application for the **All Lights On** command is to use it in conjunction with the Burglary Bell Output to turn on all the lights when a burglar alarm is occurring. When an Alarm Silence is performed, the lights will turn back off.

Flash Mode

Output 198/298 controls the **Flash Mode**. Turn the output ON to start the **Flash Mode**. Turn output 198/298 Off to stop the **Flash Mode** and leave all lights on. An example of an application for the **Flash Mode** is to use it conjunction with panel outputs, such as Fire Alarm Output, to inform of a fire alarm. Program the **Flash Mode** to occur when a Fire Alarm is happening to warn family members. To reset the units (lights) after the **Flash Mode** has occurred, program output 100/200 as the Sensor Reset output and then perform a Sensor Reset.

House Code Device and LX-Bus Output Number Conversion Tables

The following tables convert each device code into the corresponding LX-Bus output number. In the left-hand column, find the X-10 device you are controlling with the LX-Bus output. Then use the middle column for LX-Bus 1 output numbers or the right-hand column for LX-Bus 2 output numbers. House Codes A through F are converted to LX-Bus output numbers in Table 4. Table 5 converts House Codes G through L to LX-Bus output numbers.

X-10 Device	LX-Bus 1 Output #	LX-Bus 2 Output #
A 1	101	201
A 2	102	202
A 3	103	203
A 4	104	204
A 5	105	205
A 6	106	206
A 7	107	207
A 8	108	208
A 9	109	209
A 10	110	210
A 11	111	211
A 12	112	212
A 13	113	213
A 14	114	214
A 15	115	215
A 16	116	216
B 1	117	217
B 2	118	218
B 3	119	219
B 4	120	220
B 5	121	221
B 6	122	222
B 7	123	223
B 8	124	224
B 9	125	225
B 10	126	226
B 11	127	227
B 12	128	228
B 13	129	229
B 14	130	230
B 15	131	231
B 16	132	232

X-10 Device	LX-Bus 1 Output #	LX-Bus 2 Output #
C 1	133	233
C 2	134	234
C 3	135	235
C 4	136	236
C 5	137	237
C 6	138	238
C 7	139	239
C 8	140	240
C 9	141	241
C 10	142	242
C 11	143	243
C 12	144	244
C 13	145	245
C 14	146	246
C 15	147	247
C 16	148	248
D 1	149	249
D 2	150	250
D 3	151	251
D 4	152	252
D 5	153	253
D 6	154	254
D 7	155	255
D 8	156	256
D 9	157	257
D 10	158	258
D 11	159	259
D 12	160	260
D 13	161	261
D 14	162	262
D 15	163	263
D 16	164	264

X-10 Device	LX-Bus 1 Output #	LX-Bus 2 Output #
E 1	165	265
E 2	166	266
E 3	167	267
E 4	168	268
E 5	169	269
E 6	170	270
E 7	171	271
E 8	172	272
E 9	173	273
E 10	174	274
E 11	175	275
E 12	176	276
E 13	177	277
E 14	178	278
E 15	179	279
E 16	180	280
F 1	181	281
F 2	182	282
F 3	183	283
F 4	184	284
F 5	185	285
F 6	186	286
F 7	187	287
F 8	188	288
F 9	189	289
F 10	190	290
F 11	191	291
F 12	192	292
F 13	193	293
F 14	194	294
F 15	195	295
F 16	196	296

Table 4: House Code Devices A through F (Jumper Setting: 0 0)

X-10 Device	LX-Bus 1 Ouput #	LX-Bus 2 Ouput #
G 1	101	201
G 2	102	202
G 3	103	203
G 4	104	204
G 5	105	205
G 6	106	206
G 7	107	207
G 8	108	208
G 9	109	209
G 10	110	210
G 11	111	211
G 12	112	212
G 13	113	213
G 14	114	214
G 15	115	215
G 16	116	216
H 1	117	217
H 2	118	218
H 3	119	219
H 4	120	220
H 5	121	221
H 6	122	222
H 7	123	223
H 8	124	224
H 9	125	225
H 10	126	226
H 11	127	227
H 12	128	228
H 13	129	229
H 14	130	230
H 15	131	231
H 16	132	232

X-10 Device	LX-Bus 1 Ouput #	LX-Bus 2 Ouput #
I 1	133	233
I 2	134	234
I 3	135	235
I 4	136	236
I 5	137	237
I 6	138	238
I 7	139	239
I 8	140	240
I 9	141	241
I 10	142	242
I 11	143	243
I 12	144	244
I 13	145	245
I 14	146	246
I 15	147	247
I 16	148	248
J 1	149	249
J 2	150	250
J 3	151	251
J 4	152	252
J 5	153	253
J 6	154	254
J 7	155	255
J 8	156	256
J 9	157	257
J 10	158	258
J 11	159	259
J 12	160	260
J 13	161	261
J 14	162	262
J 15	163	263
J 16	164	264

X-10 Device	LX-Bus 1 Ouput #	LX-Bus 2 Ouput #
K 1	165	265
K 2	166	266
K 3	167	267
K 4	168	268
K 5	169	269
K 6	170	270
K 7	171	271
K 8	172	272
K 9	173	273
K 10	174	274
K 11	175	275
K 12	176	276
K 13	177	277
K 14	178	278
K 15	179	279
K 16	180	280
L 1	181	281
L 2	182	282
L 3	183	283
L 4	184	284
L 5	185	285
L 6	186	286
L 7	187	287
L 8	188	288
L 9	189	289
L 10	190	290
L 11	191	291
L 12	192	292
L 13	193	293
L 14	194	294
L 15	195	295
L 16	196	296

Table 5: House Code Devices G through L (Jumper Setting: 1 0)

Specifications

Operating Voltage 12 VDC
 Current Draw 13mA standby
 Dimensions 5.0" H x 3.0" W

DMP Panel Compatibility

XR200 Command Processor™ Panel
 XR200-485 Command Processor™ Panel
 XR2400F Addressable Fire Alarm Control Panel

X-10 Interface Compatibility

The 739 Module is compatible with the following devices available from a variety of X-10 dealers.

PSC04 Powerline Interface Module
 PSC05 Two-Way Powerline Interface Module

RadioShack® Part Numbers

PL513 Powerline Interface Module
 TW523 Two-Way Powerline Interface Module



800-641-4282

www.dmp.com

Made in the USA

INTRUSION • FIRE • ACCESS • NETWORKS

2500 North Partnership Boulevard

Springfield, Missouri 65803-8877